



22-01-2024
Fiyat Listesi





“Siz üretirken biz destek oluyoruz”
“We support while you produce”





Misyonumuz

Sürdürülebilir kalkınmayı kendimize yol haritası kabul ederek; çevreye duyarlı, en az maliyetle, paydaşlarımızın isteklerini karşılayan bir şirket olmaktır.

Our Mission

To be a company which recognise sustainable development as a road map to us to meet the demands of our clients with environmentally sensitive with minimal cost.

Vizyonumuz

Toplam kalite felsefesi ile Dünya Sanayisi'ne güvenilir, kaliteli ürün ve hizmet vermektir.

Müşteri istek ve ihtiyaçlarını tam olarak anlamak ve karşılamak, kalite yönetim sistemimizin gelişimini ve etkinliğini sağlayarak iç ve dış pazarda rekabet gücümüzü arttırmak, sürekli gelişmek için tüm çalışanların eğitimini ve katılımını sağlamak, ürün kalitemizi arttırmak ve maliyetlerimizi düşürmek.

Sektörümüzdeki teknolojik gelişmeleri yakından takip etmek ve bu gelişmeleri her alanda uygulamak.

























Vision

With the philosophy of total quality; serve the World Industrial Estate reliable and high quality products.

Understand exactly what the clients requests and needs; provide the development and effectiveness of our quality management system to increase our competitiveness in domestic and international market; to continuous development ensure the training and participation of all employees; improve the products quality and reduce the costs.

Follow the technological developments in our industry and implement these developments in all areas.

İÇİNDEKİLER INDEX

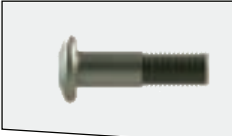
sayfa/page	12-16	 DIŞ KANAL KATERLERİ EXTERNAL GROOVING TOOLHOLDERS	P-SİSTEM İÇ ÇAP TORNALAMA KATERLERİ P-SYSTEM INTERNAL TURNING TOOLHOLDERS		sayfa/page	48-49
sayfa/page	17	 DIŞ KANAL KATERLERİ OTOMAT EXTERNAL GROOVING TOOLHOLDERS AUTOMAT	ŞAFTLI TARAMALAR MILLING TOOLS		sayfa/page	51-77
sayfa/page	18-19	 KESME TAKIMLARI BLADE TOOLS	ŞAFTLI TARAMALAR HIGH FEED MILLING TOOLS HIGH FEED		sayfa/page	78-86
sayfa/page	21-23	 İÇ KANAL KATERLERİ INTERNAL GROOVING TOOLHOLDERS	VİDALI TAKIM TUTUCULARI SCREW TOOL HOLDERS		sayfa/page	87
sayfa/page	25-29	 S-SİSTEM DIŞ ÇAP TORNALAMA KATERLERİ S-SYSTEM EXTERNAL TURNING TOOLHOLDERS	HIGH FEED FINISH TAKIMLARI HIGH FEED FINISH TOOLS		sayfa/page	89
sayfa/page	31-32	 C-SİSTEM DIŞ ÇAP TORNALAMA KATERLERİ C-SYSTEM EXTERNAL TURNING TOOLHOLDERS	FREZELEME TAKIMLARI FACE MILLING		sayfa/page	91-93
sayfa/page	33-35	 T-SİSTEM DIŞ ÇAP TORNALAMA KATERLERİ T-SYSTEM EXTERNAL TURNING TOOLHOLDERS	TARAMA KAFALARI FACE MILLING		sayfa/page	95-127
sayfa/page	36	 M-SİSTEM DIŞ ÇAP TORNALAMA KATERLERİ M-SYSTEM EXTERNAL TURNING TOOLHOLDERS	HIGH FEED TARAMA KAFALARI HIGH FEED MILLINGS		sayfa/page	128-138
sayfa/page	37-38	 P-SİSTEM DIŞ ÇAP TORNALAMA KATERLERİ P-SYSTEM EXTERNAL TURNING TOOLHOLDERS	VİDALI TARAMALAR SCREW TYPE		sayfa/page	140-153
sayfa/page	40-43	 S-SİSTEM İÇ ÇAP TORNALAMA KATERLERİ S-SYSTEM INTERNAL TURNING TOOLHOLDERS	U-DRILLER U-DRILLS		sayfa/page	155-162
sayfa/page	45	 C-SİSTEM İÇ ÇAP TORNALAMA KATERLERİ C-SYSTEM INTERNAL TURNING TOOLHOLDERS	KATERLER CUTTING TOOLS		sayfa/page	163-164
sayfa/page	45-47	 T-SİSTEM İÇ ÇAP TORNALAMA KATERLERİ T-SYSTEM INTERNAL TURNING TOOLHOLDERS	YUMUŞAK AYAKLAR SOFT JAWS		sayfa/page	165
sayfa/page	47-48	 M-SİSTEM İÇ ÇAP TORNALAMA KATERLERİ M-SYSTEM INTERNAL TURNING TOOLHOLDERS	YEDEK PARÇALAR SPARE PARTS		sayfa/page	166-168

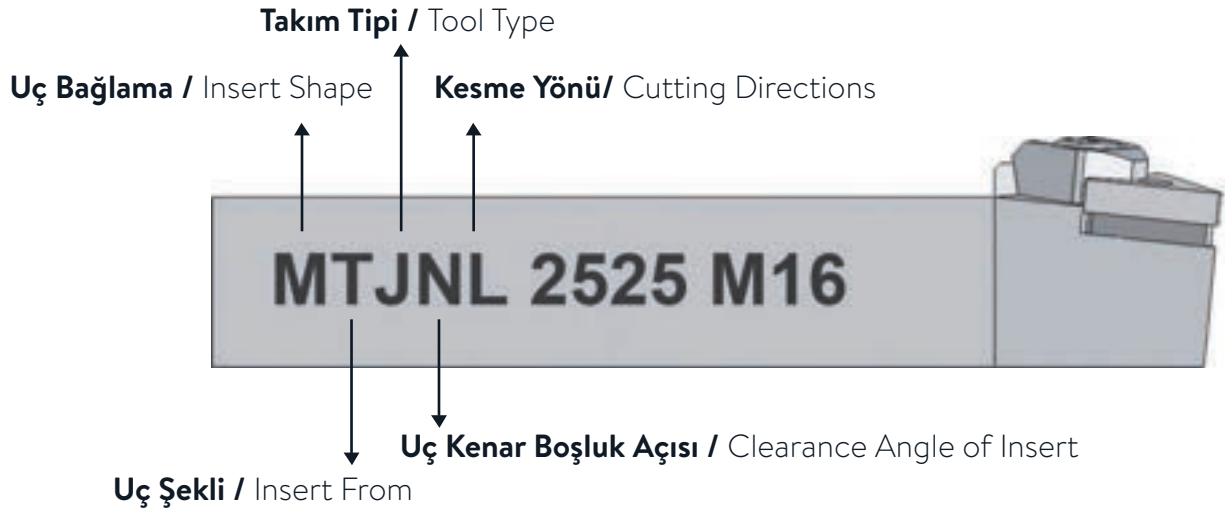

Takım Tipi / Tool Type ————— **Kesme Yönü / Cutting Directions**

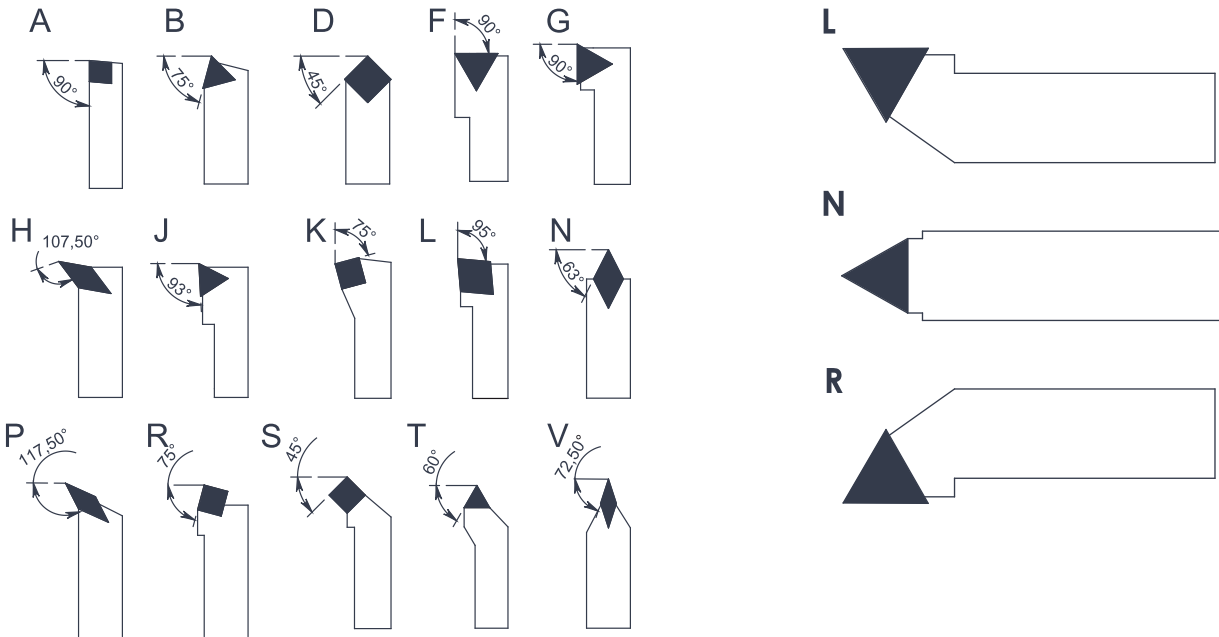

Uç Şekli / Insert From ————— **Uç Kenar Boşluk Açısı / Clearance Angle of Insert**

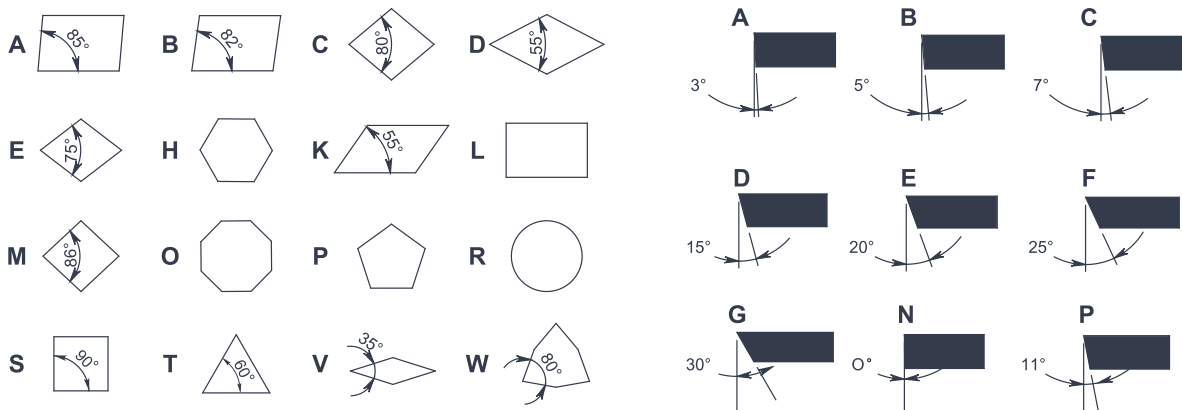

M Sistem
M System

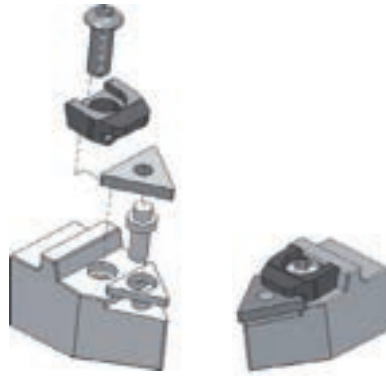

S Sistem
S System

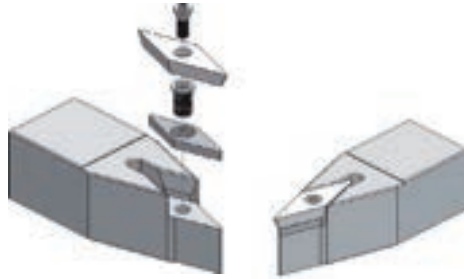

T Sistem
T System





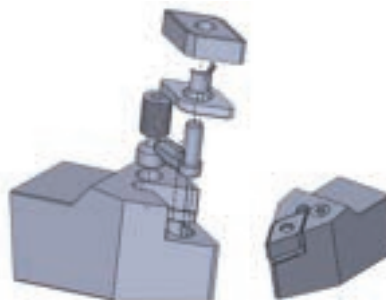



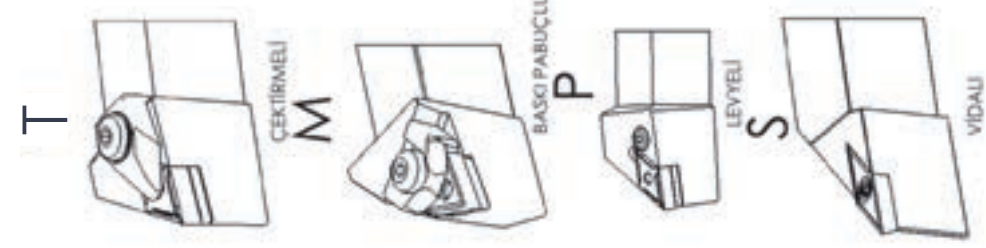

P Sistem
P System

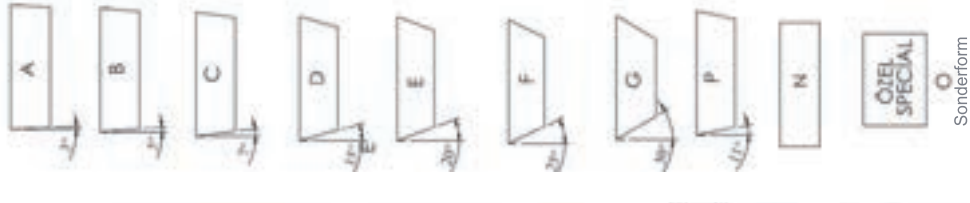

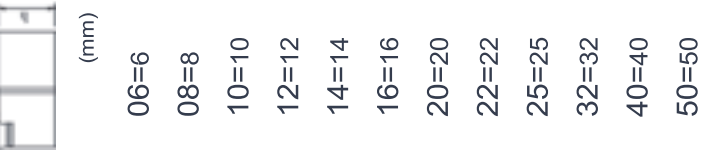
DIŞ ÇAP KATERLERİ İÇİN ISO KODLARI

EXTERNAL TURNING TOOLS ISO CODES

1	2	3	4	5	6	7	8	9
T	D	J	N	R	20	20	K	15
1	2	3	4	5	6	7	8	9
Uç Bağlama Sistemi Clamping System Klemmsystem	Kesici Uç Tipi Insert form WSP - Form	Kater Tipi Style Werkzeugtyp	Uç Açısı Clearance angle WSP-Freiwinkel	Kater Yönü Holder execution Bearbeitungs-richtung	Şaft Yüksekliği Height of shank Schaftquerschnitts	Şaft Genişliği Width of shank Schaftbreite	Takım Boyu Length of holder Werkzeuglänge	Uç Kenar Uzunluğu Length of cutting ed WSP-Größe
 <p>T ÇEKİRMELİ M BASLI PABUÇLU P LEYVELİ S VIDALI</p>	 <p>A B C D E H K L M O P R S T V W</p>	 <p>A B C D E F G J K L N P Q R S V</p>	 <p>A B C D E F G P N ÖZEL SPECIAL Sonderform</p>	 <p>L R N</p>	 <p>(mm) 06=6 08=8 10=10 12=12 14=14 16=16 20=20 22=22 25=25 32=32 40=40 50=50</p>	 <p>(mm) 06=6 08=8 10=10 12=12 14=14 16=16 20=20 22=22 25=25 32=32 40=40 50=50</p>	 <p>(mm) D=60 E=70 F=80 G=90 H=100 J=110 K=125 L=140 M=150 N=160 P=170 Q=180 R=200 S=250 T=300 U=350 V=400 W=450 Y=500 X=ÖZEL Special Sonderform</p>	 <p>A (mm) B C D E K L M O P R S T V W</p>

TORNALAMA UÇLARI İÇİN ISO KODLARI

TURNING INSERT ISO CODES

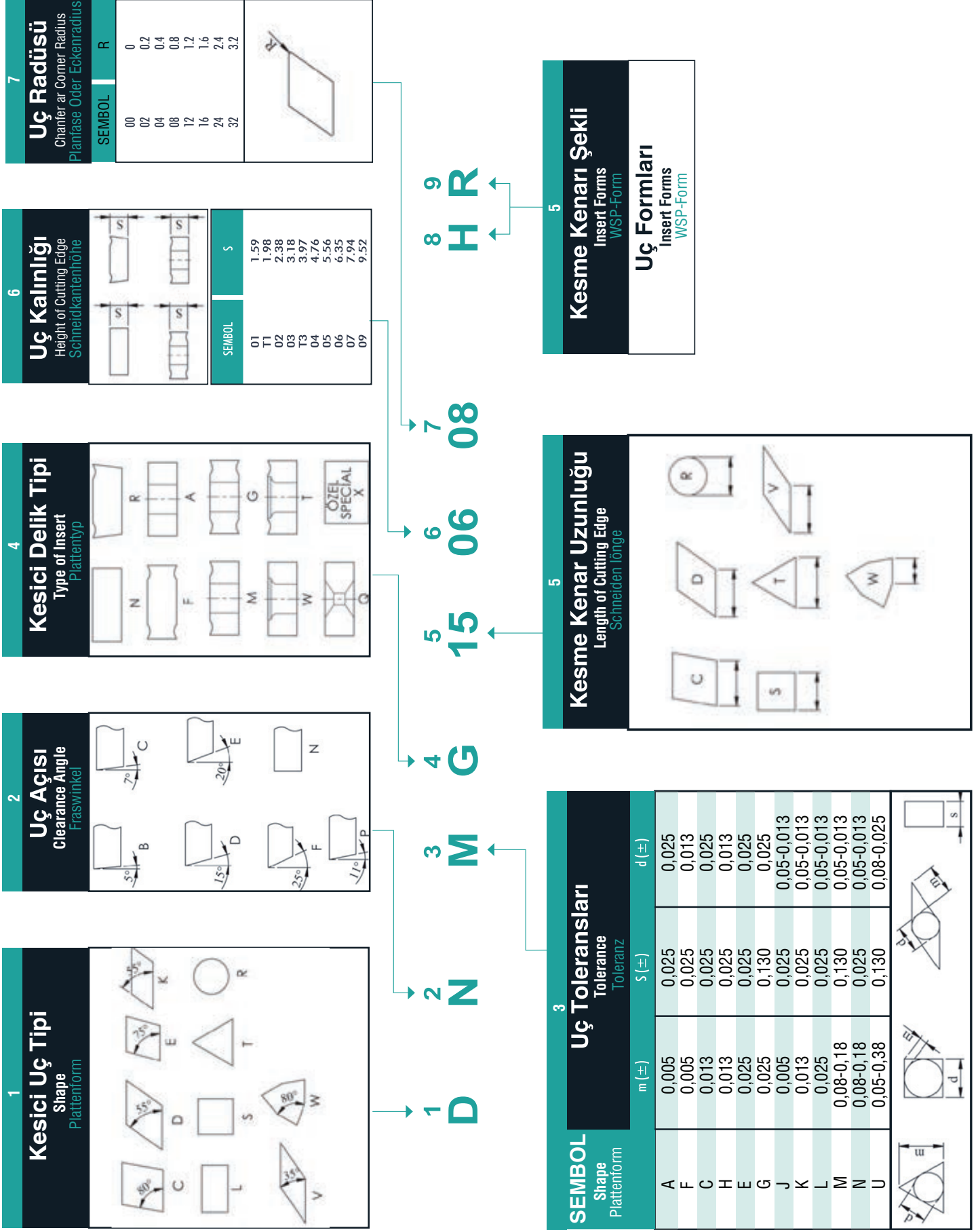



DIŐ KANAL KATERLERİ

EXTERNAL GROOVING TOOLHOLDERS

DKT I

DKT K

DKT H

KOD	Stok / Stock		Kesici Uç Uyumluluđu / Insert Suitability	FİYAT PRICE
	R	L		TL
DKT I 001 DGN	✓	✓	DKT I 12X12 2C (Tmax=14)	923
DKT I 021 DGN	✓	✓	DKT I 16X16 2C (Tmax=18)	963
DKT I 003 DGN	✓	✓	DKT I 20X20 2C (Tmax=18)	1.008
DKT I 004 DGN	✓	✓	DKT I 25X25 2C (Tmax=22)	1.048
DKT I 005 DGN	✓	✓	DKT I 12X12 3C (Tmax=14)	923
DKT I 006 DGN	✓	✓	DKT I 16X16 3C (Tmax=18)	963
DKT I 007 DGN	✓	✓	DKT I 20X20 3C (Tmax=18)	1.008
DKT I 008 DGN	✓	✓	DKT I 25X25 3C (Tmax=22)	1.048
DKT I 009 DGN	✓	✗	DKT I 32X32 3C (Tmax=22)	1.262
DKT I 010 DGN	✓	✓	DKT I 16X16 4C (Tmax=18)	963
DKT I 011 DGN	✓	✓	DKT I 20X20 4C (Tmax=18)	1.008
DKT I 012 DGN	✓	✓	DKT I 25X25 4C (Tmax=22)	1.048
DKT I 013 DGN	✓	✗	DKT I 32X32 4C (Tmax=22)	1.262
DKT I 014 DGN	✓	✓	DKT I 20X20 5C (Tmax=22)	1.008
DKT I 015 DGN	✓	✓	DKT I 25X25 5C (Tmax=22)	1.048
DKT I 016 DGN	✓	✗	DKT I 32X32 5C (Tmax=22)	1.262
DKT I 017 DGN	✓	✓	DKT I 25X25 6C (Tmax=22)	1.048
DKT I 018 DGN	✓	✗	DKT I 32X32 6C (Tmax=22)	1.262
DKT I 019 DGN	✓	✓	DKT I 25X25 3C (Tmax=40)	1.720
DKT I 020 DGN	✓	✓	DKT I 25X25 4C (Tmax=40)	1.720

KOD	Stok / Stock		Kesici Uç Uyumluluđu / Insert Suitability	FİYAT PRICE
	R	L		TL
DKT K 001 MGM.	✓	✓	DKT K 12X12 2C (Tmax=14)	923
DKT K 002 MGM.	✓	✓	DKT K 16X16 2C (Tmax=17)	963
DKT K 003 MGM.	✓	✓	DKT K 20X20 2C (Tmax=17)	1.008
DKT K 004 MGM.	✓	✓	DKT K 25X25 2C (Tmax=18)	1.048
DKT K 005 MGM.	✓	✗	DKT K 32X32 2C (Tmax=21)	1.262
DKT K 006 MGM.	✓	✓	DKT K 12X12 3C (Tmax=14)	923
DKT K 007 MGM.	✓	✓	DKT K 16X16 3C (Tmax=18)	963
DKT K 008 MGM.	✓	✓	DKT K 20X20 3C (Tmax=18)	1.008
DKT K 009 MGM.	✓	✓	DKT K 25X25 3C (Tmax=21)	1.048
DKT K 010 MGM.	✓	✗	DKT K 32X32 3C (Tmax=25)	1.262
DKT K 011 MGM.	✓	✓	DKT K 16X16 4C (Tmax=18)	963
DKT K 012 MGM.	✓	✓	DKT K 20X20 4C (Tmax=18)	1.008
DKT K 013 MGM.	✓	✓	DKT K 25X25 4C (Tmax=22)	1.048
DKT K 014 MGM.	✓	✗	DKT K 32X32 4C (Tmax=25)	1.262
DKT K 015 MGM.	✓	✓	DKT K 20X20 5C (Tmax=21)	1.008
DKT K 016 MGM.	✓	✓	DKT K 25X25 5C (Tmax=22)	1.048
DKT K 017 MGM.	✓	✗	DKT K 32X32 5C (Tmax=25)	1.262
DKT K 018 MGM.	✓	✓	DKT K 25X25 6C (Tmax=22)	1.048
DKT K 019 MGM.	✓	✗	DKT K 32X32 6C (Tmax=25)	1.262
DKT K 020 MGM.	✓	✓	DKT K 16X16 1,5C (Tmax=17)	963
DKT K 022 MGM.	✓	✓	DKT K 20X20 1,5C (Tmax=17)	1.008
DKT K 023 MGM.	✓	✓	DKT K 25X25 4C (Tmax=40)	1.720
DKT K 028 MGM.	✓	✓	DKT K 25X25 3C (Tmax=30)	1.619
DKT K 029 MGM.	✓	✓	DKT K 25X25 4C (Tmax=30)	1.619
DKT K 030 MGM.	✓	✓	DKT K 25X25 3C (Tmax=40)	1.720
DKT K 031 MGM.	✓	✓	DKT K 25X25 5C (Tmax=40)	1.720

KOD	Stok / Stock		Kesici Uç Uyumluluđu / Insert Suitability	FİYAT PRICE
	R	L		TL
DKT H 001 S229	✓	✓	DKT H 16X16 3C (Tmax=22)	963
DKT H 002 S229	✓	✓	DKT H 20X20 3C (Tmax=22)	1.008
DKT H 003 S229	✓	✓	DKT H 25X25 3C (Tmax=23)	1.048
DKT H 004 S229	✓	✗	DKT H 32X32 3C (Tmax=24)	1.262
DKT H 005 S229	✓	✓	DKT H 20X20 4C (Tmax=22)	1.008
DKT H 006 S229	✓	✓	DKT H 25X25 4C (Tmax=23)	1.048
DKT H 007 S229	✓	✗	DKT H 32X32 4C (Tmax=24)	1.262
DKT H 008 S229	✓	✓	DKT H 20X20 5C (Tmax=22)	1.008
DKT H 009 S229	✓	✓	DKT H 25X25 5C (Tmax=23)	1.048
DKT H 010 S229	✓	✗	DKT H 32X32 5C (Tmax=24)	1.262
DKT H 011 S229	✓	✓	DKT H 25X25 6C (Tmax=23)	1.048

DKT HK



KOD	Stok / Stock		Kesici Uç Uyumluluğu / Insert Suitability	FIYAT PRICE
	R	L	HRN S224	TL
DKT HK 001 S224	✓	✓	DKT HK 16X16 2C (Tmax=20)	963
DKT HK 002 S224	✓	✓	DKT HK 20X20 2C (Tmax=20)	1.008
DKT HK 003 S224	✓	✓	DKT HK 25X25 2C (Tmax=22)	1.048
DKT HK 004 S224	✓	✓	DKT HK 16X16 3C (Tmax=20)	963
DKT HK 005 S224	✓	✓	DKT HK 20X20 3C (Tmax=20)	1.008
DKT HK 006 S224	✓	✓	DKT HK 25X25 3C (Tmax=22)	1.048
DKT HK 007 S224	✓	✗	DKT HK 32X32 3C (Tmax=22)	1.262
DKT HK 008 S224	✓	✓	DKT HK 16X16 4C (Tmax=20)	963
DKT HK 009 S224	✓	✓	DKT HK 20X20 4C (Tmax=20)	1.008
DKT HK 010 S224	✓	✓	DKT HK 25X25 4C (Tmax=22)	1.048
DKT HK 011 S224	✓	✗	DKT HK 32X32 4C (Tmax=22)	1.262

DKT TT



KOD	Stok / Stock		Kesici Uç Uyumluluğu / Insert Suitability	FIYAT PRICE
	R	L	TGTC TD..	TL
DKT TT 001 TD..	✓	✗	DKT TT 12X12 2C (Tmax=14)	923
DKT TT 002 TD..	✓	✓	DKT TT 16X16 2C (Tmax=18)	963
DKT TT 003 TD..	✓	✓	DKT TT 20X20 2C (Tmax=18)	1.008
DKT TT 004 TD..	✓	✓	DKT TT 25X25 2C (Tmax=21)	1.048
DKT TT 005 TD..	✓	✗	DKT TT 12X12 3C (Tmax=14)	923
DKT TT 006 TD..	✓	✓	DKT TT 16X16 3C (Tmax=18)	963
DKT TT 007 TD..	✓	✓	DKT TT 20X20 3C (Tmax=18)	1.008
DKT TT 008 TD..	✓	✓	DKT TT 25X25 3C (Tmax=21)	1.048
DKT TT 009 TD..	✓	✗	DKT TT 32X32 3C (Tmax=23)	1.262
DKT TT 010 TD..	✓	✓	DKT TT 16X16 4C (Tmax=18)	963
DKT TT 011 TD..	✓	✓	DKT TT 20X20 4C (Tmax=18)	1.008
DKT TT 012 TD..	✓	✓	DKT TT 25X25 4C (Tmax=21)	1.048
DKT TT 013 TD..	✓	✗	DKT TT 32X32 4C (Tmax=23)	1.262
DKT TT 014 TD..	✓	✓	DKT TT 25X25 5C (Tmax=21)	1.048

DKT ZCC2



KOD	Stok / Stock		Kesici Uç Uyumluluğu / Insert Suitability	FIYAT PRICE
	R	L	ZCC ZT.D	TL
DKT ZCC2 001 ZT.D	✓	✓	DKT ZCC2 20X20 2C (Tmax=17)	1.008
DKT ZCC2 002 ZT.D	✓	✓	DKT ZCC2 25X25 2C (Tmax=21)	1.048
DKT ZCC2 004 ZT.D	✓	✓	DKT ZCC2 20X20 2,5C (Tmax=17)	1.008
DKT ZCC2 005 ZT.D	✓	✓	DKT ZCC2 25X25 2,5C (Tmax=21)	1.048
DKT ZCC2 006 ZT.D	✓	✓	DKT ZCC2 16X16 3C (Tmax=18)	963
DKT ZCC2 007 ZT.D	✓	✓	DKT ZCC2 20X20 3C (Tmax=18)	1.008
DKT ZCC2 008 ZT.D	✓	✓	DKT ZCC2 25X25 3C (Tmax=21)	1.048
DKT ZCC2 009 ZT.D	✓	✓	DKT ZCC2 16X16 4C (Tmax=18)	963
DKT ZCC2 010 ZT.D	✓	✓	DKT ZCC2 20X20 4C (Tmax=18)	1.008
DKT ZCC2 011 ZT.D	✓	✓	DKT ZCC2 25X25 4C (Tmax=21)	1.048
DKT ZCC2 012 ZT.D	✓	✗	DKT ZCC2 32X32 4C (Tmax=25)	1.262
DKT ZCC2 013 ZT.D	✓	✓	DKT ZCC2 16X16 5C (Tmax=18)	963
DKT ZCC2 014 ZT.D	✓	✓	DKT ZCC2 20X20 5C (Tmax=21)	1.008
DKT ZCC2 015 ZT.D	✓	✓	DKT ZCC2 25X25 5C (Tmax=22)	1.048
DKT ZCC2 016 ZT.D	✓	✗	DKT ZCC2 32X32 5C (Tmax=25)	1.262
DKT ZCC2 017 ZT.D	✗	✗	DKT ZCC2 20X20 6C (Tmax=21)	1.008
DKT ZCC2 018 ZT.D	✓	✗	DKT ZCC2 25X25 6C (Tmax=22)	1.048
DKT ZCC2 019 ZT.D	✓	✗	DKT ZCC2 32X32 6C (Tmax=25)	1.262
DKT ZCC2 020 ZT.D	✓	✓	DKT ZCC2 20X20 2,5C (Tmax=22)	1.008
DKT ZCC2 021 ZT.D	✓	✓	DKT ZCC2 16X16 2C (Tmax=17)	963

DKT KYC



KOD	Stok / Stock		Kesici Uç Uyumluluğu / Insert Suitability	FİYAT PRICE
	R	L		
DKT KY 001 GDM	✓	✗	DKT KY 12X12 2C (Tmax=12)	923
DKT KY 002 GDM	✓	✗	DKT KY 16X16 2C (Tmax=17)	963
DKT KY 003 GDM	✓	✗	DKT KY 20X20 2C (Tmax=17)	1.008
DKT KY 004 GDM	✓	✓	DKT KY 25X25 2C (Tmax=18)	1.048
DKT KY 005 GDM	✓	✗	DKT KY 12X12 3C (Tmax=12)	923
DKT KY 006 GDM	✓	✓	DKT KY 16X16 3C (Tmax=20)	963
DKT KY 007 GDM	✓	✓	DKT KY 20X20 3C (Tmax=20)	1.008
DKT KY 008 GDM	✓	✓	DKT KY 25X25 3C (Tmax=21)	1.048
DKT KY 009 GDM	✓	✗	DKT KY 16X16 4C (Tmax=17)	963
DKT KY 010 GDM	✓	✓	DKT KY 20X20 2C (Tmax=17)	1.008
DKT KY 011 GDM	✓	✗	DKT KY 25X25 2C (Tmax=10)	1.048
DKT KY 012 GDM	✓	✗	DKT KY 25X25 3C (Tmax=25)	1.048
DKT KY 013 GDM	✓	✗	DKT KY 25X25 4C (Tmax=25)	1.048

DKT SND



KOD	Stok / Stock		Kesici Uç Uyumluluğu / Insert Suitability	FİYAT PRICE
	R	L		
DKT SND 001 SND	✓	✓	DKT SND 12X12 2C (Tmax=12)	923
DKT SND 002 SND	✓	✓	DKT SND 12X12 3C (Tmax=12)	923
DKT SND 003 SND	✓	✓	DKT SND 20X20 2C (Tmax=18)	1.008
DKT SND 004 SND	✓	✓	DKT SND 25X25 2C (Tmax=21)	1.048
DKT SND 007 SND	✓	✓	DKT SND 20X20 3C (Tmax=18)	1.008
DKT SND 008 SND	✓	✓	DKT SND 25X25 3C (Tmax=21)	1.048
DKT SND 011 SND	✓	✓	DKT SND 20X20 4C (Tmax=20)	1.008
DKT SND 012 SND	✓	✓	DKT SND 25X25 4C (Tmax=21)	1.048
DKT SND 014 SND	✓	✓	DKT SND 20X20 5C (Tmax=21)	1.008
DKT SND 015 SND	✓	✓	DKT SND 25X25 5C (Tmax=23)	1.048
DKT SND 016 SND	✓	✗	DKT SND 32X32 5C (Tmax=25)	1.262
DKT SND 019 SND	✓	✓	DKT SND 25X25 1,5C (Tmax=18)	1.048
DKT SND 020 SND	✓	✓	DKT SND 16X16 1,5C (Tmax=18)	963
DKT SND 021 SND	✓	✓	DKT SND 20X20 1,5C (Tmax=18)	1.008
DKT SND 022 SND	✓	✓	DKT SND 16X16 2C (Tmax=18)	963

DKT KM



KOD	Stok / Stock		Kesici Uç Uyumluluğu / Insert Suitability	FİYAT PRICE
	R	L		
DKT KM 003 GMN	✓	✗	DKT KM 16X16 2C A4 GMN (Tmax=18)	963
DKT KM 004 GMN	✓	✗	DKT KM 20X20 2C A4 GMN (Tmax=18)	1.008
DKT KM 005 GMN	✓	✗	DKT KM 20X20 3C A4 GMN (Tmax=18)	1.008
DKT KM 006 GMN	✓	✗	DKT KM 20X20 4C A4 GMN (Tmax=18)	1.008
DKT KM 007 GMN	✓	✗	DKT KM 25X25 2C A4 GMN (Tmax=22)	1.048
DKT KM 008 GMN	✓	✗	DKT KM 25X25 3C A4 GMN (Tmax=22)	1.048
DKT KM 009 GMN	✓	✗	DKT KM 25X25 4C A4 GMN (Tmax=22)	1.048
DKT KM 010 GMN	✓	✗	DKT KM 25X25 5C A4 GMN (Tmax=22)	1.048
DKT KM 011 GMN	✓	✗	DKT KM 25X25 6C A4 GMN (Tmax=22)	1.048

DKT TNG



KOD	Stok / Stock		Kesici Uç Uyumluluđu / Insert Suitability	FİYAT PRICE
	R	L		
DKT TNG 001 TNG	✓	✓	DKT TNG 16X16 2C (Tmax=17)	963
DKT TNG 002 TNG	✓	✓	DKT TNG 20X20 2C (Tmax=20)	1.008
DKT TNG 003 TNG	✓	✓	DKT TNG 25X25 2C (Tmax=22)	1.048

DKT VG



KOD	Stok / Stock		Kesici Uç Uyumluluđu / Insert Suitability	FİYAT PRICE
	R	L		
DKT VG 001 VRG	✓	✗	DKT VG 20X20 2C (Tmax=20)	1.008
DKT VG 002 VRG	✓	✗	DKT VG 20X20 3C (Tmax=20)	1.008
DKT VG 003 VRG	✓	✗	DKT VG 25X25 2C (Tmax=22)	1.048
DKT VG 004 VRG	✓	✗	DKT VG 25X25 3C (Tmax=22)	1.048
DKT VG 005 VRG	✓	✗	DKT VG 25X25 4C (Tmax=22)	1.048
DKT VG 006 VRG	✓	✗	DKT VG 32X32 3C (Tmax=24)	1.262
DKT VG 007 VRG	✓	✗	DKT VG 32X32 4C (Tmax=24)	1.262

DKT H 360



KOD	Stok / Stock		Kesici Uç Uyumluluđu / Insert Suitability	FİYAT PRICE
	R	L		
DKT H 360 001 S312	✓	✓	DKT H 360 16X16 1C	963
DKT H 360 002 S312	✓	✓	DKT H 360 20X20 1C	1.008
DKT H 360 003 S312	✓	✓	DKT H 360 25X25 1C	1.048
DKT H 360 004 S312	✓	✓	DKT H 360 16X16 2C	963
DKT H 360 005 S312	✓	✓	DKT H 360 20X20 2C	1.008
DKT H 360 006 S312	✓	✓	DKT H 360 25X25 2C	1.048
DKT H 360 007 S312	✓	✓	DKT H 360 16X16 3C	963
DKT H 360 008 S312	✓	✓	DKT H 360 20X20 3C	1.008
DKT H 360 009 S312	✓	✓	DKT H 360 25X25 3C	1.048

ALIN KANAL KATERİ



KOD	Stok / Stock		Kesici Uç Uyumluluđu / Insert Suitability	FİYAT PRICE
	R	L		
AKT K 001 KRLY MGM	✓	✗	AKT K 25X25 3C (30-40) (Tmax=17)	1.468
AKT K 002 KRLY MGM	✓	✗	AKT K 25X25 3C (35-50) (Tmax=17)	1.468
AKT K 003 KRLY MGM	✓	✗	AKT K 25X25 3C (45-70) (Tmax=17)	1.468
AKT K 004 KRLY MGM	✓	✗	AKT K 25X25 3C (65-105) (Tmax=17)	1.468
AKT K 005 KRLY MGM	✓	✗	AKT K 25X25 3C (100-150) (Tmax=17)	1.468
AKT K 006 KRLY MGM	✓	✗	AKT K 25X25 4C (30-40) (Tmax=17)	1.468
AKT K 007 KRLY MGM	✓	✗	AKT K 25X25 4C (35-50) (Tmax=17)	1.468
AKT K 008 KRLY MGM	✓	✗	AKT K 25X25 4C (45-70) (Tmax=17)	1.468
AKT K 009 KRLY MGM	✓	✗	AKT K 25X25 4C (65-105) (Tmax=17)	1.468
AKT K 010 KRLY MGM	✓	✗	AKT K 25X25 4C (100-150) (Tmax=17)	1.468
AKT K 011 KRLY MGM	✓	✗	AKT K 25X25 5C (75-110) (Tmax=20)	1.468
AKT K 012 KRLY MGM	✓	✗	AKT K 25X25 5C (105-150) (Tmax=20)	1.468
AKT K 013 KRLY MGM	✓	✗	AKT K 25X25 5C (145-200) (Tmax=20)	1.468

ALIN KANAL KATERİ



KOD	Stok / Stock		Kesici Uç Uyumluluđu / Insert Suitability	FİYAT PRICE
	R	L		
AKT ZCC 001	✓	✗	AKT ZCC 25X25 3C (25-35) (Tmax=17)	1.468
AKT ZCC 002	✓	✗	AKT ZCC 25X25 3C (35-45) (Tmax=17)	1.468
AKT ZCC 003	✓	✗	AKT ZCC 25X25 3C(39-55) (Tmax=17)	1.468
AKT ZCC 004	✓	✗	AKT ZCC 25X25 3C (49-80) (Tmax=17)	1.468
AKT ZCC 005	✓	✗	AKT ZCC 25X25 3C (70-110) (Tmax=17)	1.468
AKT ZCC 006	✓	✗	AKT ZCC 25X25 3C (100-150) (Tmax=17)	1.468
AKT ZCC 007	✓	✗	AKT ZCC 25X25 4C (40-60) (Tmax=22)	1.468
AKT ZCC 008	✓	✗	AKT ZCC 25X25 4C (52-80) (Tmax=22)	1.468
AKT ZCC 009	✓	✗	AKT ZCC 25X25 4C (72-110) (Tmax=22)	1.468
AKT ZCC 010	✓	✗	AKT ZCC 25X25 4C (100-150) (Tmax=22)	1.468
AKT ZCC 011	✓	✗	AKT ZCC 25X25 4C (140-200) (Tmax=22)	1.468
AKT ZCC 012	✓	✗	AKT ZCC 25X25 5C (55-95) (Tmax=25)	1.468
AKT ZCC 013	✓	✗	AKT ZCC 25X25 5C (85-140) (Tmax=25)	1.468
AKT ZCC 014	✓	✗	AKT ZCC 25X25 5C (130-200) (Tmax=25)	1.468
AKT ZCC 015	✓	✓	AKT ZCC 25X25 L 3C (70-110) (Tmax=25)	1.468
AKT ZCC 016	✓	✗	AKT ZCC 25X25 6C T32 (88-180)	1.760
AKT ZCC 017	✗	✓	AKT ZCC 25X25 L 6C T38 (120-240)	1.920
AKT ZCC 018	✗	✓	AKT ZCC 25X25 L 3C TMAX10 (70-110)	1.468

ALIN KANAL KATERİ



KOD	Stok / Stock		Kesici Uç Uyumluluđu / Insert Suitability	FİYAT PRICE
	R	L		
LKT K 001 KRLY MGMN	✓	✗	LKT K 25X25 3C (30-40) Tmax: 14	1.468
LKT K 002 KRLY MGMN	✓	✗	LKT K 25X25 3C (35-50) Tmax: 14	1.468
LKT K 003 KRLY MGMN	✓	✗	LKT K 25X25 3C (45-70) Tmax: 14	1.468
LKT K 004 KRLY MGMN	✓	✗	LKT K 25X25 3C (65-105) Tmax: 14	1.468
LKT K 005 KRLY MGMN	✓	✗	LKT K 25X25 3C (100-150) Tmax: 14	1.468
LKT K 006 KRLY MGMN	✓	✗	LKT K 25X25 3C (150-200) Tmax: 14	1.468
LKT K 007 KRLY MGMN	✓	✗	LKT K 25X25 3C (200-300) Tmax: 14	1.468
LKT K 008 KRLY MGMN	✓	✗	LKT K 25X25 3C (300-500) Tmax: 14	1.468
LKT K 009 KRLY MGMN	✓	✗	LKT K 25X25 4C (35-50) Tmax: 17	1.468
LKT K 010 KRLY MGMN	✓	✗	LKT K 25X25 4C (45-70) Tmax: 17	1.468
LKT K 011 KRLY MGMN	✓	✗	LKT K 25X25 4C (65-105) Tmax: 17	1.468
LKT K 012 KRLY MGMN	✓	✗	LKT K 25X25 4C (100-150) Tmax: 17	1.468
LKT K 013 KRLY MGMN	✓	✗	LKT K 25X25 4C (150-200) Tmax: 17	1.468

**DKT I
KAYAR OTOMAT**



KOD	Stok / Stock		Kesici Uç Uyumluluğu / Insert Suitability	FİYAT PRICE
	R	L		
DKT I 004 DGN KAYAR OT	✓	✓	DKT I 12X12 2C KAYAR OTOMAT (Tmax=12)	963
DKT I 005 DGN KAYAR OT	✓	✓	DKT I 16X16 2C KAYAR OTOMAT (Tmax=15)	1.008
DKT I 006 DGN KAYAR OT	✓	✓	DKT I 16X16 3C KAYAR OTOMAT (Tmax=15)	1.008
DKT I 007 DGN KAYAR OT	✓	✓	DKT I 12X12 3C KAYAR OTOMAT (Tmax=12)	963

**DKT SND
KAYAR OTOMAT**



KOD	Stok / Stock		Kesici Uç Uyumluluğu / Insert Suitability	FİYAT PRICE
	R	L		
DKT SND 001 N123 OT	✓	✓	DKT SND 12X12 1.5C OTOMAT(Tmax:12)	963
DKT SND 002 N123 OT	✓	✓	DKT SND 16X16 1.5C OTOMAT(Tmax:15)	1.008
DKT SND 003 N123 OT	✓	✓	DKT SND 12X12 2C OTOMAT(Tmax:12)	963
DKT SND 005 N123 OT	✓	✓	DKT SND 12X12 3C OTOMAT(Tmax:12)	963

**DKT KYC
KAYAR OTOMAT**



KOD	Stok / Stock		Kesici Uç Uyumluluğu / Insert Suitability	FİYAT PRICE
	R	L		
DKT KY 001 GDM OT	✓	✓	DKT KY 10X10 2C OTOMAT (Tmax:12)	963
DKT KY 002 GDM OT	✓	✓	DKT KY 12X12 2C OTOMAT (Tmax:12)	963
DKT KY 003 GDM OT	✓	✓	DKT KY 16X16 2C OTOMAT (Tmax:15)	1.008
DKT KY 004 GDM OT	✓	✓	DKT KY 12X12 3C OTOMAT (Tmax:12)	963
DKT KY 005 GDM OT	✓	✓	DKT KY 16X16 3C OTOMAT (Tmax:15)	1.008

**DKT KYC
KAYAR OTOMAT**



KOD	Stok / Stock		Kesici Uç Uyumluluğu / Insert Suitability	FİYAT PRICE
	R	L		
DKT ZCC2 003 KAYAR OT	✓	✓	DKT ZCC2 12X12 2C KAYAR OTOMAT(Tmax:12)	963
DKT ZCC2 004 KAYAR OT	✓	✓	DKT ZCC2 16X16 2C KAYAR OTOMAT(Tmax:15)	1.008
DKT ZCC2 005 KAYAR OT	✓	✓	DKT ZCC2 16X16 3C KAYAR OTOMAT(Tmax:15)	1.008
DKT ZCC2 006 KAYAR OT	✓	✓	DKT ZCC 12X12 3C R KAYAR OTOMAT(Tmax:12)	963

LTT

KOD	Stok / Stock	Kesici Uç Uyumluluđu / Insert Suitability	FIYAT PRICE
		LTT	TL
LTT 001	✓	20x26 LAMA TUTUCU TAKIM	1.600
LTT 002	✓	20x32 LAMA TUTUCU TAKIM	1.600
LTT 003	✓	25x26 LAMA TUTUCU TAKIM	1.650
LTT 004	✓	25x32 LAMA TUTUCU TAKIM	1.700
LTT 005	✓	32x32 LAMA TUTUCU TAKIM	1.800

MBL I

KOD	Stok / Stock	Kesici Uç Uyumluluđu / Insert Suitability	FIYAT PRICE
		MBL I	TL
MBL I 002	✓	MBL I 26 3C	1.100
MBL I 003	✓	MBL I 32 3C	1.225

MBL K



KOD	Stok / Stock	Kesici Uç Uyumluluğu / Insert Suitability		FIYAT PRICE
		MBL KRLY MGM		TL
MBL K 002	✓	MBL K 26 3C		1.100
MBL K 003	✓	MBL K 26 3C		1.100
MBL K 004	✓	MBL K 26 4C		1.100
MBL K 005	✓	MBL K 32 2C		1.274
MBL K 006	✓	MBL K 32 3C		1.274
MBL K 007	✓	MBL K 32 4C		1.274

MBL ZCC



KOD	Stok / Stock	Kesici Uç Uyumluluğu / Insert Suitability		FIYAT PRICE
		MBL ZCC ZT.D		TL
MBL ZCC 002	✓	MBL ZCC 26 3C		1.100
MBL ZCC 003	✓	MBL ZCC 32 3C		1.274



İÇ KANAL KATERLERİ

INTERNAL GROOVING TOOLHOLDERS



KOD	Stok / Stock	Kesici Uç Uyumluluğu / Insert Suitability		FIYAT PRICE
		KRLY MGM		TL
IKT K 001 MGM	✓	IKT K 16 2C (Tmax=4)		880
IKT K 002 MGM	✓	IKT K 20 2C (Tmax=4)		923
IKT K 003 MGM	✓	IKT K 25 2C (Tmax=5,5)		1.008
IKT K 004 MGM	✓	IKT K 32 2C (Tmax=6)		1.110
IKT K 005 MGM	✓	IKT K 20 3C (Tmax=4,5)		923
IKT K 006 MGM	✓	IKT K 25 3C (Tmax=6)		1.008
IKT K 007 MGM	✓	IKT K 32 3C (Tmax=9)		1.110
IKT K 008 MGM	✓	IKT K 20 4C (Tmax=4,5)		923
IKT K 009 MGM	✓	IKT K 25 4C (Tmax=6)		1.008
IKT K 010 MGM	✓	IKT K 32 4C (Tmax=9)		1.110
IKT K 011 MGM	✓	IKT K 40 3C (Tmax=10)		1.833
IKT K 012 MGM	✓	IKT K 40 4C (Tmax=10)		1.833
IKT K 013 MGM	✓	IKT K 40 5C (Tmax=10)		1.833
IKT K 014 MGM	✓	IKT K 32 5C (Tmax=9)		1.110
IKT K 015 MGM	✓	IKT K 25 5C (Tmax=6)		1.008



KOD	Stok / Stock	Kesici Uç Uyumluluğu / Insert Suitability		FIYAT PRICE
		I DGN.		TL
IKT I 001 DGN.	✓	IKT I 20 2C (Tmax=4,5)		923
IKT I 002 DGN.	✓	IKT I 25 2C (Tmax=6)		1.008
IKT I 003 DGN.	✓	IKT I 32 2C (Tmax=8,5)		1.110
IKT I 004 DGN.	✓	IKT I 20 3C (Tmax=4,5)		923
IKT I 005 DGN.	✓	IKT I 25 3C (Tmax=6)		1.008
IKT I 006 DGN.	✓	IKT I 32 3C (Tmax=8,5)		1.110
IKT I 007 DGN.	✓	IKT I 20 4C (Tmax=4,5)		923
IKT I 008 DGN.	✓	IKT I 25 4C (Tmax=6)		1.008
IKT I 009 DGN.	✓	IKT I 32 4C (Tmax=8,5)		1.110



KOD	Stok / Stock	Kesici Uç Uyumluluğu / Insert Suitability		FIYAT PRICE
		HRN S224		TL
IKT HK 001 S224	✓	IKT HK 20 2C (Tmax=4,5)		923
IKT HK 002 S224	✓	IKT HK 25 2C (Tmax=6,5)		1.008
IKT HK 003 S224	✓	IKT HK 32 2C (Tmax=7)		1.110
IKT HK 004 S224	✓	IKT HK 20 3C (Tmax=4,5)		923
IKT HK 005 S224	✓	IKT HK 25 3C (Tmax=6,5)		1.008
IKT HK 006 S224	✓	IKT HK 32 3C (Tmax=7)		1.110
IKT HK 007 S224	✓	IKT HK 20 4C (Tmax=4,5)		923
IKT HK 008 S224	✓	IKT HK 25 4C (Tmax=6,5)		1.008
IKT HK 009 S224	✓	IKT HK 32 4C (Tmax=7)		1.110

IKT H



IKT ZCC2



IKT SND



I GRP



KOD	Stok / Stock	Kesici Uç Uyumluluğu / Insert Suitability		FIYAT PRICE
		HRN S229		TL
IKT H 001 S229	✓	IKT H 25 3C (Tmax=8)		1.008
IKT H 002 S229	✓	IKT H 32 3C (Tmax=10)		1.110
IKT H 003 S229	✓	IKT H 40 3C (Tmax=10)		1.833
IKT H 004 S229	✓	IKT H 25 4C (Tmax=8)		1.008
IKT H 005 S229	✓	IKT H 32 4C (Tmax=10)		1.110
IKT H 006 S229	✓	IKT H 40 4C (Tmax=10)		1.833
IKT H 007 S229	✓	IKT H 25 5C (Tmax=8)		1.008
IKT H 008 S229	✓	IKT H 32 5C (Tmax=10)		1.110
IKT H 009 S229	✓	IKT H 40 5C (Tmax=10)		1.833

KOD	Stok / Stock	Kesici Uç Uyumluluğu / Insert Suitability		FIYAT PRICE
		ZCC ZT.D		TL
IKT ZCC2 001 ZT.D	✓	IKT ZCC2 20 3C (Tmax=4,5)		923
IKT ZCC2 002 ZT.D	✓	IKT ZCC2 25 3C (Tmax=6)		1.008
IKT ZCC2 003 ZT.D	✓	IKT ZCC2 32 3C (Tmax=8)		1.110
IKT ZCC2 004 ZT.D	✓	IKT ZCC2 25 4C (Tmax=6)		1.008
IKT ZCC2 005 ZT.D	✓	IKT ZCC2 32 4C (Tmax=9)		1.110
IKT ZCC2 006 ZT.D	✓	IKT ZCC2 32 5C (Tmax=9)		1.110
IKT ZCC2 007 ZT.D	✓	IKT ZCC2 40 5C (Tmax=10)		1.833
IKT ZCC2 008 ZT.D	✓	IKT ZCC2 25 2C (Tmax=6)		1.008
IKT ZCC2 009 ZT.D	✓	IKT ZCC2 16 2C (Tmax=4)		880
IKT ZCC2 010 ZT.D	✓	IKT ZCC2 20 2C (Tmax=4,5)		923

KOD	Stok / Stock	Kesici Uç Uyumluluğu / Insert Suitability		FIYAT PRICE
		SND ZCC		TL
IKT SND 001 SND	✓	IKT SND 20 3C N123 (Tmax=4,5)		923
IKT SND 002 SND	✓	IKT SND 25 3C N123 (Tmax=6)		1.008
IKT SND 003 SND	✓	IKT SND 32 3C N123 (Tmax=9)		1.110
IKT SND 004 SND	✓	IKT SND 25 4C N123 (Tmax=6)		1.008
IKT SND 005 SND	✓	IKT SND 32 4C N123 (Tmax=9)		1.110
IKT SND 007 SND	✓	IKT SND 20 2C N123 (Tmax=4,5)		923
IKT SND 008 SND	✓	IKT SND 25 2C N123 (Tmax=6)		1.008

KOD	Stok / Stock	Kesici Uç Uyumluluğu / Insert Suitability		FIYAT PRICE
		GRP I		TL
IKT I GRP 001	✓	IKT I GRP 16 3C (Tmax=4)		880
IKT I GRP 002	✓	IKT I GRP 20 3C (Tmax=4)		923
IKT I GRP 003	✓	IKT I GRP 25 3C (Tmax=5,5)		1.008

IKT ITG



KOD	Stok / Stock	Kesici Uç Uyumluluğu / Insert Suitability	FİYAT PRICE
		IKT ITG	TL
IKT ITG 001 TGM.	✓	IKT ITG 16 3C (R) (Tmax=4)	880
IKT ITG 003 TGM.	✓	IKT ITG 20 3C (R) (Tmax=4)	923
IKT ITG 005 TGM.	✓	IKT ITG 25 3C (R) (Tmax=5,5)	1.008
IKT ITG 007 TGM.	✓	IKT ITG 25 4C (R) (Tmax=5,5)	1.008
IKT ITG 009 TGM.	✓	IKT ITG 32 3C (R) (Tmax=9)	1.110
IKT ITG 011 TGM.	✓	IKT ITG 32 4C (R) (Tmax=9)	1.110

IKT KY



KOD	Stok / Stock	Kesici Uç Uyumluluğu / Insert Suitability	FİYAT PRICE
		IKT KY	TL
IKT KY 001 GDM	✓	IKT KY 20 2C (Tmax=4)	923
IKT KY 002 GDM	✓	IKT KY 20 3C (Tmax=4)	923
IKT KY 003 GDM	✓	IKT KY 25 3C (Tmax=5,5)	1.008
IKT KY 004 GDM	✓	IKT KY 32 3C (Tmax=9)	1.110
IKT KY 005 GDM	✓	IKT KY 32 4C (Tmax=9)	1.110
IKT KY 006 GDM	✓	IKT KY 40 4C (Tmax=10)	1.833
IKT KY 007 GDM	✓	IKT KY 25 4C TMAX 12	1.008
IKT KY 008 GDM	✓	IKT KY 32 4C TMAX 12	1.110
IKT KY 009 GDM	✓	IKT KY 25 2C TMAX 5	1.008
IKT KY 010 GDM	✓	IKT KY 18X16 2C T4,5	923
IKT KY 011 GDM	✓	IKT KY 18X16 3C T4,5	923
IKT KY 012 GDM	✓	IKT KY 20X16 2C (Tmax=4)	923
IKT KY 013 GDM	✓	IKT KY 20X16 3C (Tmax=4)	923
IKT KY 015 GDM	✓	IKT KY 20 4C T5.5	1.089
IKT KY 016 GDM	✓	IKT KY 25 4C TMAX 6	1.008

IKT VG



KOD	Stok / Stock	Kesici Uç Uyumluluğu / Insert Suitability	FİYAT PRICE
		IKT VG	TL
IKT VG 001 VRG	✓	IKT VG 20 2C (Tmax=4)	923
IKT VG 002 VRG	✓	IKT VG 20 3C (Tmax=4)	923
IKT VG 003 VRG	✓	IKT VG 25 2C (Tmax=5,5)	1.008
IKT VG 004 VRG	✓	IKT VG 25 3C (Tmax=5,5)	1.008
IKT VG 005 VRG	✓	IKT VG 25 4C (Tmax=5,5)	1.008
IKT VG 006 VRG	✓	IKT VG 32 2C (Tmax=9)	1.110
IKT VG 007 VRG	✓	IKT VG 32 3C (Tmax=9)	1.110
IKT VG 008 VRG	✓	IKT VG 32 4C (Tmax=9)	1.110



S-SİSTEM DIŞ ÇAP TORNALAMA KATERLER

S-SYSTEM EXTERNAL TURNING TOOLHOLDERS

SVJBR ISO



93°

SVVBN ISO



62,5°

SVHBR ISO



107,5°

SVJCR ISO



93°

KOD	Stok / Stock		Kesici Uç Uyumluluğu / Insert Suitability	FİYAT PRICE
	R	L		
SVJBR 001 ISO	✓	✓	SVJBR 12X12 H11	572
SVJBR 002 ISO	✓	✓	SVJBR 16X16 H11	643
SVJBR 003 ISO	✓	✓	SVJBR 16X16 H16	690
SVJBR 004 ISO	✓	✓	SVJBR 20X20 K11	690
SVJBR 005 ISO	✓	✓	SVJBR 20X20 K16	714
SVJBR 006 ISO	✓	✓	SVJBR 25X25 M16	734
SVJBR 007 ISO	✓	✓	SVJBR 32X32 P16	890
SVJBR 008 ISO	✓	✓	SVJBR 25X25 M11	714
SVJBR 011 ISO	✗	✗	SVJBR 12X12 K11	572

KOD	Stok / Stock		Kesici Uç Uyumluluğu / Insert Suitability	FİYAT PRICE
	R	L		
SVVBN 001 ISO	✓		SVVBN 12X12 H11	572
SVVBN 002 ISO	✓		SVVBN 16X16 H11	643
SVVBN 003 ISO	✓		SVVBN 20X20 K11	690
SVVBN 004 ISO	✓		SVVBN 16X16 H16	690
SVVBN 006 ISO	✓		SVVBN 20X20 K16	714
SVVBN 007 ISO	✓		SVVBN 25X25 M16	734
SVVBN 008 ISO	✓		SVVBN 32X32 P16	890

KOD	Stok / Stock		Kesici Uç Uyumluluğu / Insert Suitability	FİYAT PRICE
	R	L		
SVHBR 000 ISO	✗	✗	SVHBR 12X12 H11	572
SVHBR 001 ISO	✓	✓	SVHBR 16X16 H11	643
SVHBR 002 ISO	✓	✓	SVHBR 20X20 K11	690
SVHBR 003 ISO	✓	✓	SVHBR 20X20 K16	714
SVHBR 004 ISO	✓	✓	SVHBR 25X25 M16	734
SVHBR 005 ISO	✓	✓	SVHBR 32X32 P16	890

KOD	Stok / Stock		Kesici Uç Uyumluluğu / Insert Suitability	FİYAT PRICE
	R	L		
SVJCR 001 ISO	✓	✓	SVJCR 12X12 H11	572
SVJCR 002 ISO	✓	✓	SVJCR 16X16 H11	643
SVJCR 003 ISO	✓	✓	SVJCR 16X16 H16	690
SVJCR 004 ISO	✓	✓	SVJCR 20X20 K11	690
SVJCR 005 ISO	✓	✓	SVJCR 20X20 K16	714
SVJCR 006 ISO	✓	✓	SVJCR 25X25 M16	734
SVJCR 007 ISO	✓	✓	SVJCR 32X32 P16	890

SVVCN ISO

72,5°

SDNCN ISO

62,5°

SDJCR ISO

93°

SCLCR ISO

95°

KOD	Stok / Stock		Kesici Uç Uyumluluğu / Insert Suitability		FİYAT PRICE
			ISO		TL
SVVCN 001 ISO	✓		SVVCN 12X12 H11		572
SVVCN 002 ISO	✓		SVVCN 16X16 H11		572
SVVCN 003 ISO	✓		SVVCN 20X20 K11		690
SVVCN 004 ISO	✓		SVVCN 16X16 H16		690
SVVCN 005 ISO	✓		SVVCN 20X20 K16		690
SVVCN 006 ISO	✓		SVVCN 25X25 M16		734
SVVCN 007 ISO	✓		SVVCN 32X32 P16		890

KOD	Stok / Stock		Kesici Uç Uyumluluğu / Insert Suitability		FİYAT PRICE
			ISO		TL
SDNCN 001 ISO	✓		SDNCN 8X8 H07		572
SDNCN 002 ISO	✓		SDNCN 10X10 H07		572
SDNCN 003 ISO	✓		SDNCN 12X12 H07		572
SDNCN 004 ISO	✓		SDNCN 16X16 H07		643
SDNCN 005 ISO	✓		SDNCN 16X16 H11		643
SDNCN 006 ISO	✓		SDNCN 20X20 K11		690
SDNCN 007 ISO	✓		SDNCN 25X25 M11		734
SDNCN 008 ISO	✓		SDNCN 32X32 P11		857
SDNCN 009 ISO	✓		SDNCN 12X12 M11		572

KOD	Stok / Stock		Kesici Uç Uyumluluğu / Insert Suitability		FİYAT PRICE
	R	L	ISO		TL
SDJCR 001 ISO	✓	✓	SDJCR 8X8 H07		572
SDJCR 002 ISO	✓	✓	SDJCR 10X10 H07		572
SDJCR 003 ISO	✓	✓	SDJCR 12X12 H07		572
SDJCR 004 ISO	✓	✓	SDJCR 16X16 H07		643
SDJCR 005 ISO	✓	✓	SDJCR 16X16 H11		643
SDJCR 006 ISO	✓	✓	SDJCR 20X20 K11		690
SDJCR 007 ISO	✓	✓	SDJCR 25X25 M11		734
SDJCR 008 ISO	✓	✓	SDJCR 32X32 P11		857

KOD	Stok / Stock		Kesici Uç Uyumluluğu / Insert Suitability		FİYAT PRICE
	R	L	ISO		TL
SCLCR 001 ISO	✓	✓	SCLCR 8X8 H06		572
SCLCR 002 ISO	✓	✓	SCLCR 10X10 H06		572
SCLCR 003 ISO	✓	✓	SCLCR 12X12 H06		572
SCLCR 004 ISO	✓	✓	SCLCR 16X16 H06		643
SCLCR 005 ISO	✓	✓	SCLCR 16X16 H09		643
SCLCR 006 ISO	✓	✓	SCLCR 20X20 K09		690
SCLCR 007 ISO	✓	✓	SCLCR 25X25 M09		734
SCLCR 008 ISO	✓	✓	SCLCR 16X16 H12		643
SCLCR 009 ISO	✓	✓	SCLCR 20X20 K12		690
SCLCR 010 ISO	✓	✓	SCLCR 25X25 M12		734
SCLCR 011 ISO	✓	✓	SCLCR 32X32 P12		890
SCLCR 012 ISO	✓	✓	SCLCR 12X12 H09		572

SCNCN ISO



50°

KOD	Stok / Stock		Kesici Uç Uyumluluğu / Insert Suitability		FİYAT PRICE
			ISO		
SCNCN 001 ISO	✓		SCNCN 8X8 H06		572
SCNCN 002 ISO	✓		SCNCN 10X10 H06		572
SCNCN 004 ISO	✓		SCNCN 16X16 H09		643
SCNCN 005 ISO	✓		SCNCN 20X20 K09		690
SCNCN 006 ISO	✓		SCNCN 25X25 M12		734
SCNCN 008 ISO	✓		SCNCN 12X12 H06		572
SCNCN 009 ISO	✓		SCNCN 12X12 H09		572

SRGCR ISO



KOD	Stok / Stock		Kesici Uç Uyumluluğu / Insert Suitability		FİYAT PRICE
	R	L	ISO		
SRGCR 001 ISO	✓	✓	SRGCR 16X16 H08		643
SRGCR 002 ISO	✓	✓	SRGCR 20X20 K08		690
SRGCR 003 ISO	✓	✓	SRGCR 25X25 M08		734
SRGCR 004 ISO	✓	✓	SRGCR 16X16 H10		643
SRGCR 005 ISO	✓	✓	SRGCR 20X20 K10		690
SRGCR 006 ISO	✓	✓	SRGCR 25X25 M10		734
SRGCR 007 ISO	✓	✓	SRGCR 32X32 P10		890
SRGCR 008 ISO	✓	✓	SRGCR 16X16 H12		643
SRGCR 009 ISO	✓	✓	SRGCR 20X20 K12		690
SRGCR 010 ISO	✓	✓	SRGCR 25X25 M12		734
SRGCR 011 ISO	✓	✓	SRGCR 32X32 P12		890

SRDCN ISO



KOD	Stok / Stock		Kesici Uç Uyumluluğu / Insert Suitability		FİYAT PRICE
	ISO				
SRDCN 001 ISO	✓		SRDCN 16X16 H08		643
SRDCN 002 ISO	✓		SRDCN 20X20 K08		690
SRDCN 003 ISO	✓		SRDCN 25X25 M08		734
SRDCN 004 ISO	✓		SRDCN 20X20 K10		690
SRDCN 005 ISO	✓		SRDCN 25X25 M10		734
SRDCN 006 ISO	✓		SRDCN 20X20 K12		690
SRDCN 007 ISO	✓		SRDCN 25X25 M12		734
SRDCN 008 ISO	✓		SRDCN 25X25 M16		734
SRDCN 009 ISO	✓		SRDCN 16X16 H10		643
SRDCN 010 ISO	✓		SRDCN 32X32 P10		890
SRDCN 011 ISO	✓		SRDCN 32X32 P12		890

SRHCR ISO



KOD	Stok / Stock		Kesici Uç Uyumluluğu / Insert Suitability		FİYAT PRICE
	R	L	ISO		
SRHCR 001 ISO	✓	✗	SRHCR 16X16 H08		643
SRHCR 002 ISO	✓	✓	SRHCR 20X20 K08		690
SRHCR 003 ISO	✓	✓	SRHCR 25X25 M08		734
SRHCR 004 ISO	✓	✓	SRHCR 20X20 K10		690
SRHCR 005 ISO	✓	✓	SRHCR 25X25 M10		734
SRHCR 006 ISO	✓	✓	SRHCR 20X20 K12		690
SRHCR 007 ISO	✓	✓	SRHCR 25X25 M12		734
SRHCR 008 ISO	✗	✗	SRHCR 32X32 P12		890
SRHCR 009 ISO	✓	✗	SRHCR 16X16 K12		643

STFCR ISO



90°

STJCR ISO



93°

DCMT 11 OTOMAT ISO



A90°-J93°

SER ISO



KOD	Stok / Stock		Kesici Uç Uyumluluğu / Insert Suitability	FİYAT PRICE
	R	L		
STFCR 001 ISO	X	X	STFCR 16X16 H16	650
STFCR 002 ISO	✓	✓	STFCR 20X20 K16	690
STFCR 003 ISO	✓	✓	STFCR 25X25 M16	734
STFCR 004 ISO	✓	✓	STFCR 12X12 H11	572
STFCR 005 ISO	✓	✓	STFCR 16X16 H11	643

KOD	Stok / Stock		Kesici Uç Uyumluluğu / Insert Suitability	FİYAT PRICE
	R	L		
STJCR 001 ISO	X	X	STJCR 16X16 H16	650
STJCR 002 ISO	✓	✓	STJCR 20X20 K16	690
STJCR 003 ISO	✓	✓	STJCR 25X25 M16	734

KOD	Stok / Stock		Kesici Uç Uyumluluğu / Insert Suitability	FİYAT PRICE
	R	L		
OT SDACR 001 ISO	✓	✓	SDACR 12X12 K11	672
OT SDJCR 001 ISO	✓	✓	SDJCR 12X12 K11	672
OT SDJCR 002 ISO	✓	✓	SDJCR 16X16 H11	672
OT SDNCN 001 ISO	✓	✓	SDNCN 12X12 K11	672
STACR 001 ISO	✓	✓	STACR 12X12 H11	572

KOD	Stok / Stock		Kesici Uç Uyumluluğu / Insert Suitability	FİYAT PRICE
	R	L		
SER 003 ISO	✓	✓	SER 12X12 H11	643
SER 004 ISO	✓	✓	SER 12X12 H16	643
SER 005 ISO	✓	✓	SER 16X16 H11	667
SER 006 ISO	✓	✓	SER 16X16 K16	667
SER 007 ISO	✓	✓	SER 20X20 K16	714
SER 008 ISO	✓	✓	SER 25X25 M16	798
SER 009 ISO	✓	✓	SER 25X25 M22	798
SER 010 ISO	✓	✓	SER 32X32 P16	965
SER 011 ISO	✓	✓	SER 32X32 P22	965

SER ZCC



KOD	Kesici Uç Uyumluluğu / Insert Suitability		ZCC SER	FIYAT PRICE
	R	L		TL
SER 014 ZCC	✓	✓	SER 25X25 M22 U UTYPE	797
SER 015 ZCC	✓	✓	SER 25X25 M27 U UTYPE	797
SER 016 ZCC	✓	✓	SER 32X32 P22 U UTYPE	959

SIR ISO



KOD	Stok / Stock		Kesici Uç Uyumluluğu / Insert Suitability	ISO SIR16	FIYAT PRICE
	R	L			TL
SIR 001 ISO	✓	✓		S10K SIR 11	572
SIR 002 ISO	✓	✓		S12M SIR 11	572
SIR 003 ISO	✓	✓		S16-10 SIR 11	643
SIR 004 ISO	✓	✓		S16Q SIR 11	643
SIR 005 ISO	✓	✓		S16Q SIR 16	643
SIR 006 ISO	✓	✓		S20R SIR 16	690
SIR 007 ISO	✓	✓		S25S SIR 16	734
SIR 008 ISO	✓	✓		S32T SIR 16	1.063
SIR 009 ISO	✓	✓		S40V SIR 16	1.609
SIR 010 ISO	✓	✓		S25S SIR 22	757
SIR 011 ISO	✓	✓		S32T SIR 22	1.132
SIR 012 ISO	✓	✓		S40V SIR 22	1.657
SIR 013 ISO	✓	✓		S50W SIR 22	2.524
SIR 014 ISO	✓	✓		S60W SIR 22	3.577
SIR 015 ISO	✓	✓		S16-13Q SIR 16	643
SIR 016 ISO	✓	✓		S20R SIR 22	690
SIR 017 ISO	✓	✓		S20-16Q SIR 16	643

SIR ZCC



KOD	Stok / Stock		Kesici Uç Uyumluluğu / Insert Suitability	ZCC SIR	FIYAT PRICE
	R	L			TL
SIR 014 ZCC	✓	✗		SIR 0025 S22 U UTYPE	787
SIR 015 ZCC	✓	✗		SIR 0032 T22 U UTYPE	1.163
SIR 016 ZCC	✓	✗		SIR 0040 V22 U UTYPE	1.683
SIR 017 ZCC	✓	✗		SIR 0032 T27 U UTYPE	1.214
SIR 018 ZCC	✓	✗		SIR 0040 V27 U UTYPE	1.757



C-SİSTEM DIŞ ÇAP TORNALAMA KATERLERİ

C-SYSTEM EXTERNAL TURNING TOOLHOLDERS

CTGPR ISO



90°

KOD	Stok / Stock		Kesici Uç Uyumluluğu / Insert Suitability	FİYAT PRICE
	R	L		
CTGPR 001 ISO	✓	✗	CTGPR 16X16 H11	714
CTGPR 002 ISO	✓	✗	CTGPR 16X16 H16	714
CTGPR 003 ISO	✓	✗	CTGPR 20X20 K16	734
CTGPR 004 ISO	✓	✗	CTGPR 25X25 M16	774
CTGPR 005 ISO	✓	✗	CTGPR 25X25 M22	774

CKJNR ISO



93°

KOD	Stok / Stock		Kesici Uç Uyumluluğu / Insert Suitability	FİYAT PRICE
	R	L		
CKJNR 004 ISO	✓	✓	CKJNR 20X20 K16	734
CKJNR 006 ISO	✓	✓	CKJNR 25X25 M16	774
CKJNR 007 ISO	✓	✓	CKJNR 32X32 P16	1.089
CKJNR 008 ISO	✓	✓	CKJNR 40X40 R16	1.808

TDJNR ISO



93°

KOD	Stok / Stock		Kesici Uç Uyumluluğu / Insert Suitability	FİYAT PRICE
	R	L		
TDJNR 001 ISO	✓	✓	TDJNR 16X16 K11	774
TDJNR 002 ISO	✓	✓	TDJNR 20X20 K11	880
TDJNR 003 ISO	✓	✓	TDJNR 25X25 M11	923
TDJNR 004 ISO	✓	✓	TDJNR 20X20 K15	880
TDJNR 005 ISO	✓	✓	TDJNR 25X25 M15	923
TDJNR 006 ISO	✓	✓	TDJNR 32X32 P15	1.132
TDJNR 007 ISO	✓	✓	TDJNR 40X40 R15	1.808
TDJNR 008 ISO	✓	✓	TDJNR 16X16 K15	774

TDNNN ISO



62,5°

KOD	Stok / Stock		Kesici Uç Uyumluluğu / Insert Suitability	FİYAT PRICE
	R	L		
TDNNN 001 ISO	✓		TDNNN 16X16 H11	774
TDNNN 002 ISO	✓		TDNNN 20X20 K11	880
TDNNN 003 ISO	✓		TDNNN 25X25 M11	923
TDNNN 004 ISO	✓		TDNNN 20X20 K15	880
TDNNN 005 ISO	✓		TDNNN 25X25 M15	923
TDNNN 006 ISO	✓		TDNNN 32X32 P15	1.132
TDNNN 007 ISO	✓		TDNNN 40X40 R15	1.808

TTGNR ISO



90°

TTJNR ISO



93°

TSLNR ISO



95°

TSKNR ISO



75°

KOD	Stok / Stock		Kesici Uç Uyumluluğu / Insert Suitability	FIYAT
	R	L		PRICE
			ISO	TL
TTGNR 001 ISO	✓	✓	TTGNR 20X20 K16	880
TTGNR 002 ISO	✓	✓	TTGNR 25X25 M16	923
TTGNR 003 ISO	✓	✓	TTGNR 20X20 K22	923
TTGNR 004 ISO	✓	✓	TTGNR 25X25 M22	1.008
TTGNR 005 ISO	✓	✓	TTGNR 32X32 P22	1.138
TTGNR 006 ISO	✓	✓	TTGNR 40X40 R22	1.808

KOD	Stok / Stock		Kesici Uç Uyumluluğu / Insert Suitability	FIYAT
	R	L		PRICE
			ISO	TL
TTJNR 001 ISO	✓	✓	TTJNR 16X16 H16	774
TTJNR 002 ISO	✓	✓	TTJNR 20X20 K16	880
TTJNR 003 ISO	✓	✓	TTJNR 25X25 M16	923
TTJNR 004 ISO	✓	✓	TTJNR 20X20 K22	923
TTJNR 005 ISO	✓	✓	TTJNR 25X25 M22	1.008
TTJNR 006 ISO	✓	✓	TTJNR 32X32 P22	1.138
TTJNR 007 ISO	✓	✓	TTJNR 40X40 R22	1.808

KOD	Stok / Stock		Kesici Uç Uyumluluğu / Insert Suitability	FIYAT
	R	L		PRICE
			ISO	TL
TSLNR 001 ISO	✓	✓	TSLNR 20X20 K12	880
TSLNR 002 ISO	✓	✓	TSLNR 25X25 M12	923
TSLNR 003 ISO	✓	✓	TSLNR 32X32 P12	1.132
TSLNR 004 ISO	✓	✓	TSLNR 40X40 R19	1.955
TSLNR 005 ISO	✓	✓	TSLNR 32X32 P15	1.163
TSLNR 006 ISO	✓	✓	TSLNR 40X40 R15	1.955
TSLNR 007 ISO	✓	✓	TSLNR 32X32 P19	1.222

KOD	Stok / Stock		Kesici Uç Uyumluluğu / Insert Suitability	FIYAT
	R	L		PRICE
			ISO	TL
TSKNR 001 ISO	✓	✓	TSKNR 20X20 K12	880
TSKNR 002 ISO	✓	✓	TSKNR 25X25 M12	923
TSKNR 005 ISO	✓	✓	TSKNR 32X32 P15	1.163
TSKNR 007 ISO	✓	✓	TSKNR 40X40 R19	1.955

TSRNR ISO



15°

TSDNN ISO



45°

TSSNR ISO



45°

TWLNR ISO



95°

KOD	Stok / Stock		Kesici Uç Uyumluluğu / Insert Suitability	FIYAT PRICE
	R	L	ISO	TL
TSRNR 001 ISO	✓	✓	TSRNR 20X20 K12	880
TSRNR 002 ISO	✓	✓	TSRNR 25X25 M12	923
TSRNR 003 ISO	✓	✓	TSRNR 32X32 P15	1.163
TSRNR 004 ISO	✓	✓	TSRNR 40X40 R19	1.955
TSRNR 005 ISO	✓	✓	TSRNR 32X32 P12	1.132
TSRNR 006 ISO	✓	✓	TSRNR 32X32 P19	1.222
TSRNR 007 ISO	✓	✓	TSRNR 40X40 R15	1.955

KOD	Stok / Stock		Kesici Uç Uyumluluğu / Insert Suitability	FIYAT PRICE
	R	L	ISO	TL
TSDNN 001 ISO	✓		TSDNN 20X20 K12	880
TSDNN 002 ISO	✓		TSDNN 25X25 M12	923
TSDNN 003 ISO	✓		TSDNN 32X32 P15	1.163
TSDNN 004 ISO	✓		TSDNN 40X40 R19	1.955
TSDNN 005 ISO	✓		TSDNN 32X32 P12	1.132
TSDNN 006 ISO	✓		TSDNN 32X32 P19	1.222
TSDNN 007 ISO	✓		TSDNN 40X40 R15	1.955

KOD	Stok / Stock		Kesici Uç Uyumluluğu / Insert Suitability	FIYAT PRICE
	R	L	ISO	TL
TSSNR 001 ISO	✓	✓	TSSNR 20X20 K12	880
TSSNR 002 ISO	✓	✓	TSSNR 25X25 M12	923
TSSNR 003 ISO	✓	✓	TSSNR 32X32 P15	1.163
TSSNR 004 ISO	✓	✓	TSSNR 40X40 R19	1.955
TSSNR 005 ISO	✓	✓	TSSNR 32X32 P12	1.132
TSSNR 006 ISO	✓	✓	TSSNR 32X32 P19	1.222

KOD	Stok / Stock		Kesici Uç Uyumluluğu / Insert Suitability	FIYAT PRICE
	R	L	ISO	TL
TWLNR 001 ISO	✓	✓	TWLNR 16X16 K06	774
TWLNR 002 ISO	✓	✓	TWLNR 20X20 K06	880
TWLNR 003 ISO	✓	✓	TWLNR 25X25 M06	923
TWLNR 004 ISO	✓	✓	TWLNR 20X20 K08	880
TWLNR 005 ISO	✓	✓	TWLNR 25X25 M08	923
TWLNR 006 ISO	✓	✓	TWLNR 32X32 P08	1.132
TWLNR 007 ISO	✓	✓	TWLNR 40X40 R08	1.808

TVJNR ISO



93°

KOD	Stok / Stock		Kesici Uç Uyumluluğu / Insert Suitability	FİYAT
	R	L		TL
TVJNR 000 ISO	✓	✓	TVJNR 16X16 K16	774
TVJNR 001 ISO	✓	✓	TVJNR 20X20 K16	880
TVJNR 002 ISO	✓	✓	TVJNR 25X25 M16	923
TVJNR 003 ISO	✓	✓	TVJNR 32X32 P16	1.132
TVJNR 004 ISO	✓	✗	TVJNR 40X40 R16	1.808

TVNNN ISO



72,5°

KOD	Stok / Stock		Kesici Uç Uyumluluğu / Insert Suitability	FİYAT
	R	L		TL
TVNNN 001 ISO	✓		TVNNN 20X20 K16	880
TVNNN 002 ISO	✓		TVNNN 25X25 M16	923
TVNNN 003 ISO	✓		TVNNN 32X32 P16	1.132
TVNNN 004 ISO	✓		TVNNN 40X40 R16	1.808

TCLNR ISO



95°

KOD	Stok / Stock		Kesici Uç Uyumluluğu / Insert Suitability	FİYAT
	R	L		TL
TCLNR 001 ISO	✓	✓	TCLNR 20X20 K12	880
TCLNR 002 ISO	✓	✓	TCLNR 25X25 M12	923
TCLNR 003 ISO	✓	✓	TCLNR 32X32 P12	1.222
TCLNR 004 ISO	✓	✓	TCLNR 25X25 M16	1.089
TCLNR 005 ISO	✓	✓	TCLNR 32X32 P16	1.222
TCLNR 006 ISO	✓	✓	TCLNR 32X32 P19	1.394
TCLNR 007 ISO	✓	✓	TCLNR 40X40 R19	1.955
TCLNR 008 ISO	✓	✓	TCLNR 40X40 R16	1.955
TCLNR 009 ISO	✓	✓	TCLNR 16X16 H12	774

TCBNR ISO



75°

KOD	Stok / Stock		Kesici Uç Uyumluluğu / Insert Suitability	FİYAT PRICE
	R	L		
TCBNR 001 ISO	✓	✓	TCBNR 25X25 M12	923
TCBNR 002 ISO	✓	✓	TCBNR 32X32 P19	1.222
TCBNR 003 ISO	✓	✓	TCBNR 40X40 R19	2.004
TCBNR 004 ISO	✓	✓	TCBNR 20X20 K12	880
TCBNR 005 ISO	✓	✓	TCBNR 32X32 P12	1.132
TCBNR 006 ISO	✓	✓	TCBNR 32X32 P16	1.222

TCKNR ISO



75°

KOD	Stok / Stock		Kesici Uç Uyumluluğu / Insert Suitability	FİYAT PRICE
	R	L		
TCKNR 001 ISO	✓	✓	TCKNR 25X25 M12	923
TCKNR 002 ISO	✓	✓	TCKNR 25X25 M16	923
TCKNR 004 ISO	✓	✓	TCKNR 32X32 P16	1.132

TCZNN ISO



50°

KOD	Stok / Stock		Kesici Uç Uyumluluğu / Insert Suitability	FİYAT PRICE
	R	L		
TCZNN 001 ISO	✓		TCZNN 20X20 K12	880
TCZNN 002 ISO	✓		TCZNN 25X25 M12	923
TCZNN 003 ISO	✓		TCZNN 32X32 P12	1.132
TCZNN 004 ISO	✓		TCZNN 32X32 P19	1.394
TCZNN 005 ISO	✓		TCZNN 40X40 R19	1.808
TCZNN 006 ISO	✓		TCZNN 32X32 P16	1.222

TCMNN ISO



40°

KOD	Stok / Stock		Kesici Uç Uyumluluğu / Insert Suitability	FİYAT PRICE
	R	L		
TCMNN 001 ISO	✓		TCMNN 20X20 K12	880
TCMNN 002 ISO	✓		TCMNN 25X25 M12	923
TCMNN 003 ISO	✓		TCMNN 32X32 P12	1.132
TCMNN 004 ISO	✓		TCMNN 32X32 P19	1.394
TCMNN 005 ISO	✓		TCMNN 40X40 R19	1.955
TCMNN 006 ISO	✓		TCMNN 32X32 P16	1.394

MTJNR ISO



93°

MTENN ISO



60°

MWLNR ISO



95°

MWDNN ISO



50°

KOD	Stok / Stock		Kesici Uç Uyumluluğu / Insert Suitability	FİYAT PRICE
	R	L		
MTJNR 001 ISO	✓	✓	MTJNR 16X16 K16	774
MTJNR 002 ISO	✓	✓	MTJNR 20X20 K16	880
MTJNR 003 ISO	✓	✓	MTJNR 25X25 M16	923
MTJNR 004 ISO	✓	✓	MTJNR 32X32 P16	1.132
MTJNR 005 ISO	✓	✓	MTJNR 25X25 M22	923
MTJNR 006 ISO	✓	✓	MTJNR 32X32 P22	1.163
MTJNR 007 ISO	✓	✓	MTJNR 40X40 R22	1.808

KOD	Stok / Stock		Kesici Uç Uyumluluğu / Insert Suitability	FİYAT PRICE
	R	L		
MTENN 001 ISO	✓		MTENN 16X16 K16	774
MTENN 002 ISO	✓		MTENN 20X20 K16	880
MTENN 003 ISO	✓		MTENN 25X25 M16	923
MTENN 004 ISO	✓		MTENN 32X32 P16	1.132
MTENN 005 ISO	✓		MTENN 25X25 M22	923
MTENN 006 ISO	✓		MTENN 32X32 P22	1.163
MTENN 007 ISO	✓		MTENN 40X40 R22	1.808

KOD	Stok / Stock		Kesici Uç Uyumluluğu / Insert Suitability	FİYAT PRICE
	R	L		
MWLNR 001 ISO	✓	✓	MWLNR 16X16 H06	774
MWLNR 002 ISO	✓	✓	MWLNR 20X20 K06	880
MWLNR 003 ISO	✓	✓	MWLNR 25X25 M06	923
MWLNR 004 ISO	✓	✓	MWLNR 20X20 K08	880
MWLNR 005 ISO	✓	✓	MWLNR 25X25 M08	923
MWLNR 006 ISO	✓	✓	MWLNR 32X32 P08	1.132
MWLNR 007 ISO	✓	✓	MWLNR 40X40 R08	1.829

KOD	Stok / Stock		Kesici Uç Uyumluluğu / Insert Suitability	FİYAT PRICE
	R	L		
MWDNN 001 ISO	✓		MWDNN 16X16 H06	774
MWDNN 002 ISO	✓		MWDNN 20X20 K06	880
MWDNN 003 ISO	✓		MWDNN 20X20 K08	880
MWDNN 004 ISO	✓		MWDNN 25X25 M08	923
MWDNN 005 ISO	✓		MWDNN 32X32 P08	1.132
MWDNN 006 ISO	✓		MWDNN 40X40 R08	1.829

PCLNR ISO



95°

KOD	Stok / Stock		Kesici Uç Uyumluluğu / Insert Suitability	FIYAT
	R	L		TL
PCLNR 001 ISO	✓	✓	PCLNR 20X20 K12	880
PCLNR 002 ISO	✓	✓	PCLNR 25X25 M12	923
PCLNR 003 ISO	✓	✓	PCLNR 32X32 P12	1.163
PCLNR 004 ISO	✓	✓	PCLNR 40X40 R12	1.955
PCLNR 005 ISO	✓	✓	PCLNR 25X25 M16	1.072
PCLNR 006 ISO	✓	✓	PCLNR 32X32 P16	1.305
PCLNR 007 ISO	✓	✓	PCLNR 40X40 R16	1.955
PCLNR 008 ISO	✓	✓	PCLNR 32X32 P19	1.305
PCLNR 009 ISO	✓	✓	PCLNR 40X40 R19	2.004

PDJNR ISO



93°

KOD	Stok / Stock		Kesici Uç Uyumluluğu / Insert Suitability	FIYAT
	R	L		TL
PDJNR 001 ISO	✓	✓	PDJNR 20X20 K15	880
PDJNR 002 ISO	✓	✓	PDJNR 25X25 M15	923
PDJNR 003 ISO	✓	✓	PDJNR 32X32 P15	1.262
PDJNR 004 ISO	✓	✓	PDJNR 40X40 R15	1.829

PDNNN ISO



62,5°

KOD	Stok / Stock		Kesici Uç Uyumluluğu / Insert Suitability	FIYAT
	R	L		TL
PDNNN 001 ISO	✓	✓	PDNNN 20X20 K15	880
PDNNN 002 ISO	✓	✓	PDNNN 25X25 M15	923
PDNNN 003 ISO	✓	✓	PDNNN 32X32 P15	1.262
PDNNN 004 ISO	✓	✓	PDNNN 40X40 R15	1.829

PWLNR ISO



95°

KOD	Stok / Stock		Kesici Uç Uyumluluğu / Insert Suitability	FİYAT PRICE
	R	L		
PWLNR 001 ISO	✓	✓	PWLNR 20X20 K08	880
PWLNR 002 ISO	✓	✓	PWLNR 25X25 M08	923
PWLNR 003 ISO	✓	✓	PWLNR 32X32 P08	1.132
PWLNR 004 ISO	✓	✓	PWLNR 40X40 R08	1.829

PTJNR ISO



93°

KOD	Stok / Stock		Kesici Uç Uyumluluğu / Insert Suitability	FİYAT PRICE
	R	L		
PTJNR 001 ISO	X	X	PTJNR 20X20 K16	880
PTJNR 002 ISO	X	X	PTJNR 25X25 M16	923
PTJNR 003 ISO	X	X	PTJNR 32X32 P16	1.262
PTJNR 004 ISO	✓	✓	PTJNR 25X25 M22	1.008
PTJNR 005 ISO	✓	✓	PTJNR 32X32 P22	1.305
PTJNR 006 ISO	X	X	PTJNR 40X40 R22	2.004

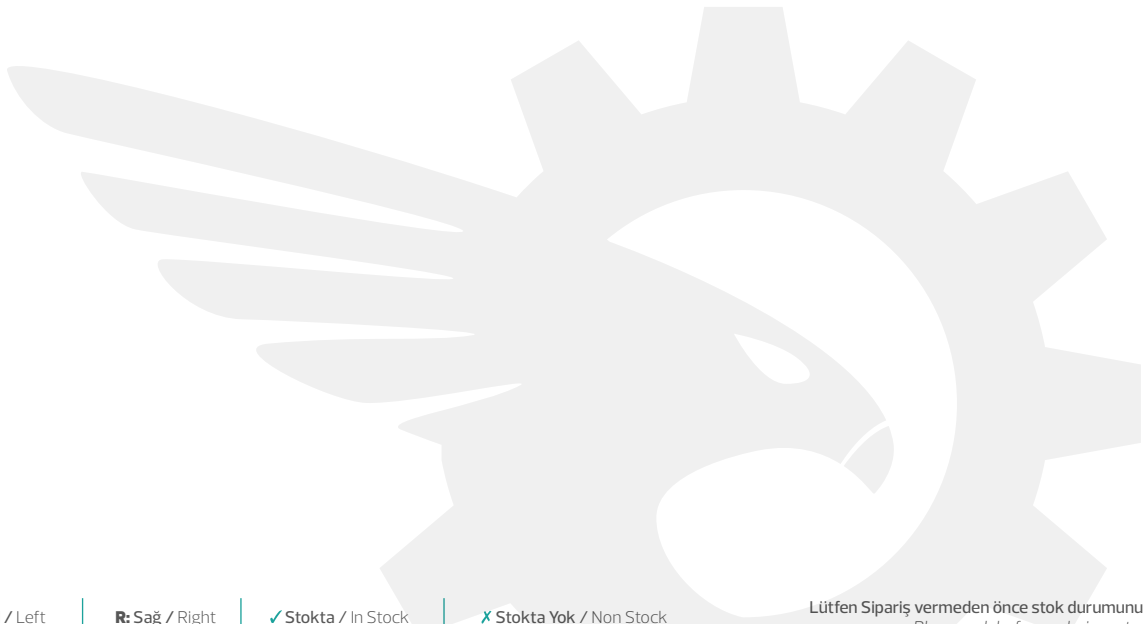



S-SİSTEM İÇ ÇAP TORNALAMA KATERLERİ

S-SYSTEM INTERNAL TURNING TOOLHOLDERS

SVUBR ISO



93°

KOD	Stok / Stock		Kesici Uç Uyumluluğu / Insert Suitability	FİYAT PRICE
	R	L		
SVUBR 001 ISO	✓	✓	S16Q SVUBR 11	630
SVUBR 002 ISO	✓	✓	S20R SVUBR 11	734
SVUBR 003 ISO	✓	✓	S25S SVUBR 16	757
SVUBR 004 ISO	✓	✓	S32T SVUBR 16	1.180
SVUBR 005 ISO	✓	✓	S40V SVUBR 16	1.885

SVUCR ISO



93°

KOD	Stok / Stock		Kesici Uç Uyumluluğu / Insert Suitability	FİYAT PRICE
	R	L		
SVUCR 001 ISO	✓	✓	S16Q SVUCR 11	630
SVUCR 002 ISO	✓	✓	S20R SVUCR 11	734
SVUCR 003 ISO	✓	✓	S25S SVUCR 16	757
SVUCR 004 ISO	✓	✓	S32T SVUCR 16	1.180
SVUCR 005 ISO	✓	✓	S40V SVUCR 16	1.885

SVJBR ISO



93°

KOD	Stok / Stock		Kesici Uç Uyumluluğu / Insert Suitability	FİYAT PRICE
	R	L		
SVJBR 001 ISO	✓	✓	S25S SVJBR 16	757
SVJBR 002 ISO	✓	✓	S32T SVJBR 16	1.180
SVJBR 003 ISO	✓	✓	S40V SVJBR 16	1.885

SDPCR ISO



97,5°

KOD	Stok / Stock		Kesici Uç Uyumluluğu / Insert Suitability	FIYAT
	R	L		TL
SDPCR 001 ISO	✓	✗	S10K SDPCR 07	417
SDPCR 002 ISO	✓	✗	S12M SDPCR 07	462
SDPCR 003 ISO	✓	✗	S16Q SDPCR 11	524
SDPCR 004 ISO	✓	✓	S20R SDPCR 11	568
SDPCR 005 ISO	✓	✓	S25S SDPCR 11	672
SDPCR 006 ISO	✓	✗	S32T SDPCR 11	1.180

SDUCR ISO



93°

KOD	Stok / Stock		Kesici Uç Uyumluluğu / Insert Suitability	FIYAT
	R	L		TL
SDUCR 001 ISO	✓	✓	S10K SDUCR 07	417
SDUCR 001 ISO (S)	✓	✓	S10K SDUCR 07 inter cooland	543
SDUCR 002 ISO	✓	✓	S12M SDUCR 07	462
SDUCR 002 ISO (S)	✓	✓	S12M SDUCR 07 inter cooland	672
SDUCR 003 ISO	✓	✓	S16Q SDUCR 07	524
SDUCR 004 ISO	✓	✓	S16Q SDUCR 11	524
SDUCR 004 ISO (S)	✓	✓	S16Q SDUCR 11 inter cooland	672
SDUCR 005 ISO	✓	✓	S20R SDUCR 07	568
SDUCR 006 ISO	✓	✓	S20R SDUCR 11	568
SDUCR 006 ISO (S)	✓	✓	S20R SDUCR 11 inter cooland	757
SDUCR 007 ISO	✓	✓	S25S SDUCR 11	672
SDUCR 007 ISO (S)	✓	✓	S25R SDUCR 11 inter cooland	857
SDUCR 008 ISO	✓	✓	S25S SDUCR 07	672
SDUCR 009 ISO	✓	✓	S32T SDUCR 11	1.180
SDUCR 010 ISO	✓	✓	S40V SDUCR 11	1.885

SDQCR ISO



107,5°

KOD	Stok / Stock		Kesici Uç Uyumluluğu / Insert Suitability	FIYAT
	R	L		TL
SDQCR 001 ISO	✓	✓	S10K SDQCR 07	417
SDQCR 001 ISO (S)	✓	✗	S10K SDQCR 07 inter cooland	590
SDQCR 002 ISO	✓	✓	S12M SDQCR 07	462
SDQCR 002 ISO (S)	✓	✗	S12M SDQCR 07 inter cooland	630
SDQCR 003 ISO	✓	✓	S16Q SDQCR 07	524
SDQCR 004 ISO	✓	✓	S20R SDQCR 07	568
SDQCR 005 ISO	✓	✓	S16Q SDQCR 11	524
SDQCR 005 ISO (S)	✓	✗	S16Q SDQCR 11 inter cooland	714
SDQCR 006 ISO	✓	✓	S20R SDQCR 11	568
SDQCR 006 ISO (S)	✓	✗	S20R SDQCR 11 inter cooland	757
SDQCR 007 ISO	✓	✓	S25S SDQCR 07	672
SDQCR 008 ISO	✓	✓	S25S SDQCR 11	672
SDQCR 009 ISO	✓	✓	S32T SDQCR 11	1.180

SD-CR ISO



62,5°

KOD	Stok / Stock		Kesici Uç Uyumluluğu / Insert Suitability	FİYAT PRICE
	R	L		
SD-CR 001 ISO	✓	✓	S10K SD-CR 07	462
SD-CR 002 ISO	✓	✓	S12M SD-CR 07	462
SD-CR 003 ISO	✓	✓	S16Q SD-CR 07	524
SD-CR 004 ISO	✓	✓	S16Q SD-CR 11	524
SD-CR 005 ISO	✓	✓	S20R SD-CR 11	568
SD-CR 006 ISO	✓	✓	S25S SD-CR 11	672
SD-CR 007 ISO	✓	✓	S32T SD-CR 11	1.180
SD-CR 008 ISO	✓	✓	S40V SD-CR 11	1.885

SDXCR ISO



93°

KOD	Stok / Stock		Kesici Uç Uyumluluğu / Insert Suitability	FİYAT PRICE
	R	L		
SDXCR 001 ISO	✓	✓	S12M SDXCR 07	462
SDXCR 002 ISO	✓	✓	S16Q SDXCR 07	524
SDXCR 003 ISO	✓	✓	S16Q SDXCR 11	524
SDXCR 004 ISO	✓	✓	S20R SDXCR 11	568
SDXCR 005 ISO	✓	✓	S25S SDXCR 11	672
SDXCR 006 ISO	✓	✓	S32T SDXCR 11	1.180
SDXCR 007 ISO	✓	✓	S40V SDXCR 11	1.885

SET SDUCR



KOD	Stok / Stock		Kesici Uç Uyumluluğu / Insert Suitability	FİYAT PRICE
	R	L		
SET 3 SDUCR ISO	✓	✓	SDUCR 10/12/16	1.329
SET 3 SDUCR ISO (S)	✓	✓	SDUCR 10/12/16 inter cooland	1.737
SET 4 SDUCR ISO	✓	✓	SDUCR 10/12/16/20	1.874
SET 4 SDUCR ISO (S)	✓	✓	SDUCR 10/12/16/20 inter cooland	2.512

SET SCLCR



SCLCR ISO



95°

STFCR ISO



90°

KOD	Stok / Stock		Kesici Uç Uyumluluğu / Insert Suitability	FİYAT PRICE
	R	L		
SET 4 SCLCR ISO	✓	✓	SCLCR 08/10/12/16	1.765
SET 4 SCLCR ISO (S)	✓	✓	SCLCR 08/10/12/16 inter cooland	2.400
SET 5 SCLCR ISO	✓	✓	SCLCR 08/10/12/16/20	2.342
SET 5 SCLCR ISO (S)	✓	✓	SCLCR 08/10/12/16/20 inter cooland	3.135
SET 6 SCLCR ISO	✓	✓	SCLCR 06/08/10/12/16/20	2.739
SET 6 SCLCR ISO (S)	✓	✓	SCLCR 06/08/10/12/16/20 inter cooland	3.710

KOD	Stok / Stock		Kesici Uç Uyumluluğu / Insert Suitability	FİYAT PRICE
	R	L		
SCLCR/S 001 ISO	✓	✓	S06-08H SCLCR 06	417
SCLCR/S 001 ISO (S)	✓	✓	S06-08H SCLCR 06inter cooland	590
SCLCR/S 002 ISO	✓	✓	S08H SCLCR 06	417
SCLCR/S 002 ISO (S)	✓	✓	S08H SCLCR 06 inter cooland	590
SCLCR/S 003 ISO	✓	✓	S10K SCLCR 06	417
SCLCR/S 003 ISO (S)	✓	✓	S10K SCLCR 06 inter cooland	590
SCLCR/S 004 ISO	✓	✓	S12M SCLCR 06	462
SCLCR/S 004 ISO (S)	✓	✓	S12M SCLCR 06 inter cooland	630
SCLCR/S 005 ISO	✓	✓	S12M SCLCR 09	489
SCLCR/S 005 ISO (S)	✓	✓	S12M SCLCR 09 inter cooland	630
SCLCR/S 006 ISO	✓	✓	S16Q SCLCR 06	524
SCLCR/S 006 ISO (S)	✓	✓	S16Q SCLCR 06 inter cooland	672
SCLCR/S 007 ISO	✓	✓	S16Q SCLCR 09	524
SCLCR/S 007 ISO (S)	✓	✓	S16Q SCLCR 09 inter cooland	672
SCLCR/S 008 ISO	✓	✓	S20R SCLCR 09	590
SCLCR/S 008 ISO (S)	✓	✓	S20R SCLCR 09 inter cooland	757
SCLCR/S 009 ISO	✓	✓	S25S SCLCR 09	734
SCLCR/S 010 ISO	✓	✓	S32T SCLCR 09	1.089
SCLCR/S 011 ISO	✓	✓	S25S SCLCR 12	734
SCLCR/S 011 ISO (S)	✓	✓	S25S SCLCR 12 inter cooland	838
SCLCR/S 012 ISO	✓	✓	S32T SCLCR 12	1.089
SCLCR/S 013 ISO	✓	✓	S40V SCLCR 12	1.885
SCLCR/S 018 ISO	✓	✓	S10-12K SCLCR 06	483
SCLCR/S 019 ISO	✓	X	S12-16M SCLCR 06	512
SCLCR/S 020 ISO	✓	X	S12-16M SCLCR 09	512

KOD	Stok / Stock		Kesici Uç Uyumluluğu / Insert Suitability	FİYAT PRICE
	R	L		
STFCR/S 001 ISO	✓	✓	S16Q STFCR 16	524
STFCR/S 002 ISO	✓	✓	S20R STFCR 16	568
STFCR/S 003 ISO	✓	✓	S25S STFCR 16	672
STFCR/S 004 ISO	✓	✓	S32T STFCR 16	1.180
STFCR/S 005 ISO	✓	✓	S12M STFCR 11	503



C-SİSTEM İÇ ÇAP TORNALAMA KATERLERİ

C-SYSTEM INTERNAL TURNING TOOLHOLDERS

C-SİSTEM İÇ ÇAP TORNALAMA KATERLERİ

C-SYSTEM INTERNAL TURNING TOOLHOLDERS

MBC
Cutting Tools

CKUNR ISO



93°

KOD	Stok / Stock		Kesici Uç Uyumluluğu / Insert Suitability	FİYAT PRICE
	R	L		
CKUNR 002 ISO	✓	✓	S25S CKUNR 16	774
CKUNR 003 ISO	✓	✓	S32T CKUNR 16	1.063
CKUNR 004 ISO	✓	✓	S40V CKUNR 16	1.905
CKUNR 005 ISO	✓	✓	S50W CKUNR 16	2.524
CKUNR 006 ISO	✓	✗	S60W CKUNR 16	3.539

CTUPR ISO



93°

KOD	Stok / Stock		Kesici Uç Uyumluluğu / Insert Suitability	FİYAT PRICE
	R	L		
CTUPR 001 ISO	✓	✗	S16Q CTUPR 16	734
CTUPR 002 ISO	✓	✗	S20R CTUPR 16	734
CTUPR 003 ISO	✓	✗	S25S CTUPR 16	757

T-SİSTEM İÇ ÇAP TORNALAMA KATERLERİ

T-SYSTEM INTERNAL TURNING TOOLHOLDERS

TDUNR ISO



93°

KOD	Stok / Stock		Kesici Uç Uyumluluğu / Insert Suitability	FİYAT PRICE
	R	L		
TDUNR 001 ISO	✓	✓	S20R TDUNR 11	963
TDUNR 002 ISO	✓	✓	S25S TDUNR 15	1.028
TDUNR 003 ISO	✓	✓	S32T TDUNR 15	1.305
TDUNR 004 ISO	✓	✓	S40V TDUNR 15	2.030
TDUNR 005 ISO	✓	✓	S50W TDUNR 15	2.575
TDUNR 006 ISO	✓	✓	S60W TDUNR 15	3.539

Lütfen Sipariş vermeden önce stok durumunu sorunuz.
Please ask before ordering, stock status.

L: Sol / Left

R: Sağ / Right

✓ Stokta / In Stock

✗ Stokta Yok / Non Stock

TDQNR ISO



107,5°

TD-NR ISO



62,5°

TCLNR ISO



95°

TWLNR ISO



95°

KOD	Stok / Stock		Kesici Uç Uyumluluğu / Insert Suitability	FİYAT PRICE
	R	L		
TDQNR 000 ISO	✓	✓	S25S TDQNR 15	1.028
TDQNR 001 ISO	✓	✓	S32T TDQNR 15	1.305
TDQNR 002 ISO	✓	✓	S40V TDQNR 15	2.030
TDQNR 003 ISO	✓	✓	S50W TDQNR 15	2.575

KOD	Stok / Stock		Kesici Uç Uyumluluğu / Insert Suitability	FİYAT PRICE
	R	L		
TD-NR 001 ISO	✓	✓	S32T TD-NR 15	1.305
TD-NR 002 ISO	✓	✓	S40V TD-NR 15	2.030
TD-NR 003 ISO	✓	X	S50W TD-NR 15	2.575

KOD	Stok / Stock		Kesici Uç Uyumluluğu / Insert Suitability	FİYAT PRICE
	R	L		
TCLNR/S 001 ISO	✓	✓	S25S TCLNR 12	1.028
TCLNR/S 002 ISO	✓	✓	S32T TCLNR 12	1.305
TCLNR/S 003 ISO	✓	✓	S40V TCLNR 16	2.203
TCLNR/S 004 ISO	✓	✓	S50W TCLNR 16	2.575
TCLNR/S 005 ISO	✓	✓	S32T TCLNR 16	1.526
TCLNR/S 006 ISO	✓	✓	S40V TCLNR 12	2.030
TCLNR/S 007 ISO	✓	X	S60W TCLNR 16	3.539
TCLNR/S 008 ISO	✓	✓	S40V TCLNR 19	2.203
TCLNR/S 009 ISO	✓	X	S50W TCLNR 19	3.095

KOD	Stok / Stock		Kesici Uç Uyumluluğu / Insert Suitability	FİYAT PRICE
	R	L		
TWLNR/S 002 ISO	✓	✓	S20R TWLNR 06	963
TWLNR/S 002 ISO (S)	✓	✓	S20R TWLNR 06 inter cooland	1.153
TWLNR/S 003 ISO	✓	✓	S25S TWLNR 08	1.028
TWLNR/S 003 ISO (S)	✓	✓	S25S TWLNR 08 inter cooland	1.214
TWLNR/S 004 ISO	✓	✓	S32T TWLNR 08	1.305
TWLNR/S 005 ISO	✓	✓	S40V TWLNR 08	2.030
TWLNR/S 006 ISO	✓	✓	S50W TWLNR 08	2.575
TWLNR/S 007 ISO	✓	✓	S60W TWLNR 08	3.539

MTUNR ISO



93°

MT-NR ISO



60°

KOD	Stok / Stock		Kesici Uç Uyumluluğu / Insert Suitability	FIYAT
	R	L		PRICE
			ISO	TL
MTUNR 001 ISO	✓	✓	S20R MTUNR 16	987
MTUNR 002 ISO	✓	✓	S25S MTUNR 16	1.089
MTUNR 003 ISO	✓	✓	S32T MTUNR 16	1.483
MTUNR 004 ISO	✓	✓	S40V MTUNR 16	2.030
MTUNR 005 ISO	✓	✓	S32T MTUNR 22	1.483
MTUNR 006 ISO	✓	✓	S40V MTUNR 22	2.030
MTUNR 007 ISO	✓	✓	S50W MTUNR 22	2.575
MTUNR 008 ISO	✓	✗	S60W MTUNR 22	3.539

KOD	Stok / Stock		Kesici Uç Uyumluluğu / Insert Suitability	FIYAT
	R	L		PRICE
			ISO	TL
MT-NR 001 ISO	✓	✓	S20R MT-NR 16	987
MT-NR 002 ISO	✓	✓	S25S MT-NR 16	1.089
MT-NR 003 ISO	✓	✓	S32T MT-NR 16	1.483
MT-NR 004 ISO	✓	✓	S40V MT-NR 16	2.030
MT-NR 005 ISO	✓	✗	S50W MT-NR 16	2.575
MT-NR 006 ISO	✓	✗	S32T MT-NR 22	1.483
MT-NR 007 ISO	✓	✗	S40V MT-NR 22	2.030

M-SİSTEM İÇ ÇAP TORNALAMA KATERLERİ

M-SYSTEM INTERNAL TURNING TOOLHOLDERS

MTQNR ISO



107,5°

KOD	Stok / Stock		Kesici Uç Uyumluluğu / Insert Suitability	FIYAT
	R	L		PRICE
			ISO	TL
MTQNR 001 ISO	✓	✓	S20R MTQNR 16	987
MTQNR 002 ISO	✓	✓	S25S MTQNR 16	1.089
MTQNR 003 ISO	✓	✓	S32T MTQNR 16	1.483
MTQNR 004 ISO	✓	✓	S40V MTQNR 16	2.030
MTQNR 005 ISO	✓	✓	S32T MTQNR 22	1.483
MTQNR 006 ISO	✓	✓	S40V MTQNR 22	2.030

MWLNR ISO



95°

KOD	Stok / Stock		Kesici Uç Uyumluluğu / Insert Suitability	FİYAT PRICE
	R	L		
MWLNR/S 001 ISO	✓	✓	S16Q MWLNR 06	880
MWLNR/S 002 ISO	✓	✓	S20R MWLNR 06	963
MWLNR/S 003 ISO	✓	✓	S25S MWLNR 08	1.089
MWLNR/S 004 ISO	✓	✓	S32T MWLNR 08	1.483
MWLNR/S 005 ISO	✓	✓	S40V MWLNR 08	2.030
MWLNR/S 006 ISO	✓	✓	S50W MWLNR 08	2.575
MWLNR/S 007 ISO	x	x	S60W MWLNR 08	3.539

P-SİSTEM İÇ ÇAP TORNALAMA KATERLERİ
P-SYSTEM INTERNAL TURNING TOOLHOLDERS

PCLNR ISO



95°

KOD	Stok / Stock		Kesici Uç Uyumluluğu / Insert Suitability	FİYAT PRICE
	R	L		
PCLNR/S 001 ISO	✓	x	S25S PCLNR 12	1.028
PCLNR/S 002 ISO	✓	x	S32T PCLNR 12	1.387
PCLNR/S 003 ISO	✓	✓	S40V PCLNR 12	2.030
PCLNR/S 004 ISO	✓	x	S32T PCLNR 16	1.387
PCLNR/S 005 ISO	✓	x	S40V PCLNR 16	2.078
PCLNR/S 007 ISO	✓	x	S40V PCLNR 19	2.177
PCLNR/S 008 ISO	x	x	S50V PCLNR 19	2.624

PDUNR ISO



93°

KOD	Stok / Stock		Kesici Uç Uyumluluğu / Insert Suitability	FİYAT PRICE
	R	L		
PDUNR/S 001 ISO	✓	x	S25S PDUNR 15	1.028
PDUNR/S 002 ISO	✓	x	S32T PDUNR 15	1.387
PDUNR/S 003 ISO	✓	x	S40V PDUNR 15	2.030

PWLNR ISO



95°

KOD	Stok / Stock		Kesici Uç Uyumluluğu / Insert Suitability	FIYAT
	R	L		PRICE
PWLNR/S 001 ISO	✓	✗	S25S PWLNR 08	1.028
PWLNR/S 002 ISO	✓	✗	S32T PWLNR 08	1.387
PWLNR/S 003 ISO	✓	✗	S40V PWLNR 08	2.030

PTUNR ISO



93°

KOD	Stok / Stock		Kesici Uç Uyumluluğu / Insert Suitability	FIYAT
	R	L		PRICE
PTUNR/S 001 ISO	✗	✗	S20R PTUNR 16	963
PTUNR/S 002 ISO	✗	✗	S25S PTUNR 16	1.028
PTUNR/S 003 ISO	✗	✗	S32T PTUNR 16	1.387
PTUNR/S 005 ISO	✓	✗	S32T PTUNR 22	1.423
PTUNR/S 006 ISO	✓	✗	S40V PTUNR 22	2.078



ŞAFTLI TARAMALAR END MILLS

APKT 1003 ISO



KOD	Stok / Stock	Kesici Uç Uyumluluğu / Insert Suitability		FİYAT PRICE
		ISO AP..1003		TL
ST AP..10 001 ISO	✓	EM90 D12 W12 L120 Z01 AP.1003		809
ST AP..10 001 ISO (S)	✓	EM90 D12 W12 L120 Z01 AP.1003 inter cooland		937
ST AP..10 002 ISO	✓	EM90 D14 W12 L120 Z01 AP.1003		850
ST AP..10 003 ISO	✓	EM90 D16 W16 L100 Z02 AP.1003		850
ST AP..10 003 ISO (S)	✓	EM90 D16 W16 L100 Z02 AP.1003 inter cooland		1.064
ST AP..10 004 ISO	✓	EM90 D16 W16 L120 Z02 AP.1003		978
ST AP..10 004 ISO (S)	✓	EM90 D16 W16 L120 Z02 AP.1003 inter cooland		1.105
ST AP..10 005 ISO	✓	EM90 D16 W16 L150 Z02 AP.1003		1.105
ST AP..10 005 ISO (S)	✓	EM90 D16 W16 L150 Z02 AP.1003 inter cooland		1.233
ST AP..10 006 ISO	✓	EM90 D16 W16 L200 Z02 AP.1003		1.322
ST AP..10 006 ISO (S)	✓	EM90 D16 W16 L200 Z02 AP.1003 inter cooland		1.449
ST AP..10 007 ISO	✓	EM90 D16 W16 L250 Z02 AP.1003		1.403
ST AP..10 008 ISO	✓	EM90 D18 W16 L100 Z02 AP.1003		850
ST AP..10 008 ISO (S)	✓	EM90 D18 W16 L100 Z02 AP.1003 inter cooland		978
ST AP..10 009 ISO	✓	EM90 D18 W16 L120 Z02 AP.1003		937
ST AP..10 009 ISO (S)	✓	EM90 D18 W16 L120 Z02 AP.1003 inter cooland		1.064
ST AP..10 010 ISO	✓	EM90 D18 W16 L150 Z02 AP.1003		1.233
ST AP..10 010 ISO (S)	✓	EM90 D18 W16 L150 Z02 AP.1003 inter cooland		1.363
ST AP..10 011 ISO	✓	EM90 D18 W16 L200 Z02 AP.1003		1.403
ST AP..10 011 ISO (S)	✓	EM90 D18 W16 L200 Z02 AP.1003 inter cooland		1.532
ST AP..10 012 ISO	✓	EM90 D20 W20 L100 Z03 AP.1003		978
ST AP..10 012 ISO (S)	✓	EM90 D20 W20 L100 Z03 AP.1003 inter cooland		1.153
ST AP..10 013 ISO	✓	EM90 D20 W20 L120 Z03 AP.1003		1.064
ST AP..10 013 ISO (S)	✓	EM90 D20 W20 L120 Z03 AP.1003 inter cooland		1.233
ST AP..10 014 ISO	✓	EM90 D18 W16 L250 Z02 AP.1003		1.492
ST AP..10 015 ISO	✓	EM90 D20 W20 L150 Z03 AP.1003		1.363
ST AP..10 015 ISO (S)	✓	EM90 D20 W20 L150 Z03 AP.1003 inter cooland		1.492
ST AP..10 016 ISO	✓	EM90 D20 W20 L200 Z03 AP.1003		1.618
ST AP..10 016 ISO (S)	✓	EM90 D20 W20 L200 Z03 AP.1003 inter cooland		1.917
ST AP..10 017 ISO	✓	EM90 D20 W20 L250 Z03 AP.1003		1.787
ST AP..10 018 ISO	✓	EM90 D22 W20 L100 Z03 AP.1003		1.023
ST AP..10 018 ISO (S)	✓	EM90 D22 W20 L100 Z03 AP.1003 inter cooland		1.233
ST AP..10 019 ISO	✓	EM90 D22 W20 L120 Z03 AP.1003		1.064
ST AP..10 019 ISO (S)	✓	EM90 D22 W20 L120 Z03 AP.1003 inter cooland		1.233
ST AP..10 020 ISO	✓	EM90 D22 W20 L150 Z03 AP.1003		1.363
ST AP..10 020 ISO (S)	✓	EM90 D22 W20 L150 Z03 AP.1003 inter cooland		1.492
ST AP..10 021 ISO	✓	EM90 D22 W20 L200 Z03 AP.1003		1.700
ST AP..10 022 ISO	✓	EM90 D22 W20 L250 Z03 AP.1003		1.917
ST AP..10 023 ISO	✓	EM90 D25 W25 L100 Z03 AP.1003		1.153
ST AP..10 023 ISO (S)	✓	EM90 D25 W25 L100 Z03 AP.1003 inter cooland		1.363
ST AP..10 024 ISO	✓	EM90 D25 W25 L120 Z03 AP.1003		1.233
ST AP..10 024 ISO (S)	✓	EM90 D25 W25 L120 Z03 AP.1003 inter cooland		1.403
ST AP..10 025 ISO	✓	EM90 D25 W25 L150 Z03 AP.1003		1.492
ST AP..10 025 ISO (S)	✓	EM90 D25 W25 L150 Z03 AP.1003 inter cooland		1.660
ST AP..10 026 ISO	✓	EM90 D25 W25 L200 Z03 AP.1003		1.787
ST AP..10 026 ISO (S)	✓	EM90 D25 W25 L200 Z03 AP.1003 inter cooland		1.958
ST AP..10 027 ISO	✓	EM90 D25 W25 L250 Z03 AP.1003		1.958
ST AP..10 028 ISO	✓	EM90 D28 W25 L150 Z04 AP.1003		1.492
ST AP..10 029 ISO	✓	EM90 D26 W25 L150 Z03 AP.1003		1.492
ST AP..10 030 ISO	✓	EM90 D26 W25 L200 Z03 AP.1003		1.787
ST AP..10 031 ISO	✓	EM90 D26 W25 L250 Z03 AP.1003		1.958
ST AP..10 032 ISO	✓	EM90 D30 W25 L100 Z04 AP.1003		1.233
ST AP..10 032 ISO (S)	✓	EM90 D30 W25 L100 Z04 AP.1003 inter cooland		1.403
ST AP..10 033 ISO	✓	EM90 D30 W25 L120 Z04 AP.1003		1.403
ST AP..10 033 ISO (S)	✓	EM90 D30 W25 L120 Z04 AP.1003 inter cooland		1.575
ST AP..10 034 ISO	✓	EM90 D30 W25 L150 Z03 AP.1003		1.575
ST AP..10 035 ISO	✓	EM90 D30 W25 L150 Z04 AP.1003		1.575
ST AP..10 035 ISO (S)	✓	EM90 D30 W25 L150 Z04 AP.1003 inter cooland		1.700

APKT 1003 ISO



KOD	Stok / Stock	Kesici Uç Uyumluluğu / Insert Suitability	FIYAT PRICE
		ISO AP..1003	TL
ST AP..10 036 ISO	✓	EM90 D30 W25 L200 Z04 AP.1003	1.917
ST AP..10 036 ISO (S)	✓	EM90 D30 W25 L200 Z04 AP.1003 inter cooland	2.085
ST AP..10 038 ISO	✓	EM90 D32 W25 L150 Z04 AP.1003	1.575
ST AP..10 039 ISO	✓	EM90 D32 W32 L150 Z04 AP.1003	1.660
ST AP..10 040 ISO	✓	EM90 D32 W32 L200 Z04 AP.1003	1.787
ST AP..10 040 ISO (S)	✓	EM90 D32 W32 L200 Z04 AP.1003 inter cooland	1.917
ST AP..10 041 ISO	✓	EM90 D35 W25 L100 Z04 AP.1003	1.363
ST AP..10 041 (S) ISO	✓	EM90 D35 W25 L100 Z04 AP.1003 inter cooland	1.492
ST AP..10 042 ISO	✓	EM90 D35 W25 L120 Z04 AP.1003	1.449
ST AP..10 043 ISO	✓	EM90 D35 W25 L150 Z04 AP.1003	1.575
ST AP..10 043 (S) ISO	✓	EM90 D35 W25 L150 Z04 AP.1003 inter cooland	1.660
ST AP..10 044 ISO	✓	EM90 D35 W25 L200 Z04 AP.1003	1.917
ST AP..10 045 ISO	✓	EM90 D35 W32 L100 Z04 AP.1003	1.449
ST AP..10 046 ISO	✓	EM90 D35 W32 L120 Z04 AP.1003	1.532
ST AP..10 047 ISO	✓	EM90 D35 W32 L150 Z04 AP.1003	1.660
ST AP..10 048 ISO	✓	EM90 D40 W25 L100 Z05 AP.1003	1.449
ST AP..10 048 ISO (S)	✓	EM90 D40 W25 L100 Z05 AP.1003 inter cooland	1.618
ST AP..10 049 ISO	✓	EM90 D40 W25 L120 Z05 AP.1003	1.492
ST AP..10 049 ISO (S)	✓	EM90 D40 W25 L120 Z05 AP.1003 inter cooland	1.660
ST AP..10 050 ISO	✓	EM90 D40 W25 L150 Z05 AP.1003	1.618
ST AP..10 050 ISO (S)	✓	EM90 D40 W25 L150 Z05 AP.1003 inter cooland	1.700
ST AP..10 051 ISO	✓	EM90 D40 W25 L200 Z05 AP.1003	2.127
ST AP..10 051 ISO (S)	✓	EM90 D40 W25 L200 Z05 AP.1003 inter cooland	2.297
ST AP..10 053 ISO	✓	EM90 D40 W32 L100 Z05 AP.1003	1.449
ST AP..10 053 ISO (S)	✓	EM90 D40 W32 L100 Z05 AP.1003 inter cooland	1.575
ST AP..10 054 ISO	✓	EM90 D40 W32 L120 Z05 AP.1003	1.492
ST AP..10 054 ISO (S)	✓	EM90 D40 W32 L120 Z05 AP.1003 inter cooland	1.618
ST AP..10 055 ISO	✓	EM90 D40 W32 L150 Z05 AP.1003	1.660
ST AP..10 055 ISO (S)	✓	EM90 D40 W32 L150 Z05 AP.1003 inter cooland	1.787
ST AP..10 056 ISO	✓	EM90 D17 W16 L150 Z02 AP.1003	1.233
ST AP..10 057 ISO	✓	EM90 D21 W20 L150 Z03 AP.1003	1.363
ST AP..10 058 ISO	✓	EM90 D21 W20 L200 Z03 AP.1003	1.700

APKT 1604 ISO



KOD	Stok / Stock	Kesici Uç Uyumluluğu / Insert Suitability	FİYAT PRICE
		ISO AP..1604..	TL
ST AP..16 001 ISO	✓	EM90 D25 W25 L100 Z02 AP..1604	978
ST AP..16 001 ISO (S)	✓	EM90 D25 W25 L100 Z02 AP..1604 inter cooland	1.194
ST AP..16 002 ISO	✓	EM90 D25 W25 L120 Z02 AP..1604	1.064
ST AP..16 002 ISO (S)	✓	EM90 D25 W25 L120 Z02 AP..1604 inter cooland	1.233
ST AP..16 003 ISO	✓	EM90 D25 W25 L150 Z02 AP..1604	1.403
ST AP..16 003 ISO (S)	✓	EM90 D25 W25 L150 Z02 AP..1604 inter cooland	1.575
ST AP..16 004 ISO	✓	EM90 D25 W25 L200 Z02 AP..1604	1.618
ST AP..16 004 ISO (S)	✓	EM90 D25 W25 L200 Z02 AP..1604 inter cooland	1.787
ST AP..16 005 ISO	✓	EM90 D25 W25 L250 Z02 AP..1604	2.085
ST AP..16 006 ISO	✓	EM90 D25 W25 L300 Z02 AP..1604	2.382
ST AP..16 007 ISO	✓	EM90 D30 W25 L100 Z03 AP..1604	1.064
ST AP..16 007 ISO (S)	✓	EM90 D30 W25 L100 Z03 AP..1604 inter cooland	1.233
ST AP..16 008 ISO	✓	EM90 D30 W25 L120 Z03 AP..1604	1.105
ST AP..16 008 ISO (S)	✓	EM90 D30 W25 L120 Z03 AP..1604 inter cooland	1.275
ST AP..16 009 ISO	✓	EM90 D30 W25 L150 Z03 AP..1604	1.449
ST AP..16 009 ISO (S)	✓	EM90 D30 W25 L150 Z03 AP..1604 inter cooland	1.618
ST AP..16 010 ISO	✓	EM90 D30 W25 L200 Z03 AP..1604	1.787
ST AP..16 010 ISO (S)	✓	EM90 D30 W25 L200 Z03 AP..1604 inter cooland	1.958
ST AP..16 011 ISO	✓	EM90 D30 W25 L250 Z03 AP..1604	2.213
ST AP..16 012 ISO	✓	EM90 D30 W25 L300 Z03 AP..1604	2.382
ST AP..16 013 ISO	✓	EM90 D32 W25 L100 Z03 AP..1604	1.064
ST AP..16 013 ISO (S)	✓	EM90 D32 W25 L100 Z03 AP..1604 inter cooland	1.233
ST AP..16 014 ISO	✓	EM90 D32 W25 L120 Z03 AP..1604	1.153
ST AP..16 014 ISO (S)	✓	EM90 D32 W25 L120 Z03 AP..1604 inter cooland	1.322
ST AP..16 015 ISO	✓	EM90 D32 W25 L150 Z03 AP..1604	1.492
ST AP..16 015 ISO (S)	✓	EM90 D32 W25 L150 Z03 AP..1604 inter cooland	1.660
ST AP..16 016 ISO	✓	EM90 D32 W25 L200 Z03 AP..1604	1.787
ST AP..16 016 ISO (S)	✓	EM90 D32 W25 L200 Z03 AP..1604 inter cooland	1.958
ST AP..16 017 ISO	✓	EM90 D32 W32 L100 Z03 AP..1604	1.105
ST AP..16 017 (S) ISO	✓	EM90 D32 W32 L100 Z03 AP..1604 inter cooland	1.275
ST AP..16 018 ISO	✓	EM90 D32 W32 L120 Z03 AP..1604	1.194
ST AP..16 018 ISO (S)	✓	EM90 D32 W32 L120 Z03 AP..1604 inter cooland	1.363
ST AP..16 019 ISO	✓	EM90 D32 W32 L150 Z03 AP..1604	1.492
ST AP..16 019 ISO (S)	✓	EM90 D32 W32 L150 Z03 AP..1604 inter cooland	1.660
ST AP..16 020 ISO	✓	EM90 D32 W32 L200 Z03 AP..1604	1.787
ST AP..16 020 ISO (S)	✓	EM90 D32 W32 L200 Z03 AP..1604 inter cooland	2.002
ST AP..16 021 ISO	✓	EM90 D32 W32 L250 Z03 AP..1604	2.297
ST AP..16 022 ISO	✓	EM90 D32 W32 L300 Z03 AP..1604	2.382
ST AP..16 023 ISO	✓	EM90 D32 W32 L350 Z03 AP..1604	2.680
ST AP..16 024 ISO	✓	EM90 D35 W25 L100 Z03 AP..1604	1.153
ST AP..16 025 ISO	✓	EM90 D35 W25 L120 Z03 AP..1604	1.233
ST AP..16 026 ISO	✓	EM90 D35 W25 L150 Z03 AP..1604	1.492
ST AP..16 027 ISO	✓	EM90 D35 W32 L100 Z03 AP..1604	1.194
ST AP..16 028 ISO	✓	EM90 D35 W32 L120 Z03 AP..1604	1.233
ST AP..16 029 ISO	✓	EM90 D35 W32 L150 Z03 AP..1604	1.492
ST AP..16 029 ISO (S)	✓	EM90 D35 W32 L150 Z03 AP..1604 inter cooland	1.660
ST AP..16 031 ISO	✓	EM90 D35 W32 L250 Z03 AP..1604	2.213
ST AP..16 032 ISO	✓	EM90 D35 W32 L300 Z03 AP..1604	2.382
ST AP..16 033 ISO	✓	EM90 D35 W32 L350 Z03 AP..1604	2.640
ST AP..16 034 ISO	✓	EM90 D40 W25 L100 Z04 AP..1604	1.233
ST AP..16 034 ISO (S)	✓	EM90 D40 W25 L100 Z04 AP..1604 inter cooland	1.403

APKT 1604 ISO



KOD	Stok / Stock	Kesici Uç Uyumluluğu / Insert Suitability		FİYAT PRICE
		ISO AP..1604..		
ST AP..16 035 ISO	✓	EM90 D40 W25 L120 Z04 AP.1604		1.363
ST AP..16 035 ISO (S)	✓	EM90 D40 W25 L120 Z04 AP.1604 inter cooland		1.492
ST AP..16 036 ISO	✓	EM90 D40 W25 L150 Z04 AP.1604		1.660
ST AP..16 036 ISO (S)	✓	EM90 D40 W25 L150 Z04 AP.1604 inter cooland		1.829
ST AP..16 037 ISO	✓	EM90 D40 W25 L200 Z04 AP.1604		2.085
ST AP..16 037 ISO (S)	✓	EM90 D40 W25 L200 Z04 AP.1604 inter cooland		2.255
ST AP..16 038 ISO	✓	EM90 D40 W32 L100 Z04 AP.1604		1.275
ST AP..16 038 ISO (S)	✓	EM90 D40 W32 L100 Z04 AP.1604 inter cooland		1.449
ST AP..16 039 ISO	✓	EM90 D40 W32 L120 Z04 AP.1604		1.363
ST AP..16 039 ISO (S)	✓	EM90 D40 W32 L120 Z04 AP.1604 inter cooland		1.532
ST AP..16 040 ISO	✓	EM90 D40 W32 L150 Z04 AP.1604		1.618
ST AP..16 040 ISO (S)	✓	EM90 D40 W32 L150 Z04 AP.1604 inter cooland		1.787
ST AP..16 041 ISO	✓	EM90 D40 W32 L200 Z04 AP.1604		2.127
ST AP..16 041 ISO (S)	✓	EM90 D40 W32 L200 Z04 AP.1604 inter cooland		2.297
ST AP..16 042 ISO	✓	EM90 D40 W32 L250 Z04 AP.1604		2.340
ST AP..16 043 ISO	✓	EM90 D40 W32 L300 Z04 AP.1604		2.512
ST AP..16 044 ISO	✓	EM90 D40 W32 L350 Z04 AP.1604		2.680
ST AP..16 045 ISO	✓	EM90 D23,5 W25 L150 Z02 AP.1604		1.403
ST AP..16 046 ISO	✓	EM90 D24 W25 L150 Z02 AP.1604		1.403
ST AP..16 047 ISO	✓	EM90 D32 W25 L250 Z03 AP.1604		2.213

TPKN 1603 ISO



KOD	Stok Stock	Inter Cooland	Kesici Uç Uyumluluğu / Insert Suitability		FİYAT PRICE
			ISO TPKN 1603		
ST TPKN 16 001 ISO	✓	×	EM90 D35 W25 L100 Z02 TPKN 1603		1.130
ST TPKN 16 002 ISO	✓	×	EM90 D40 W25 L100 Z03 TPKN 1603		1.219
ST TPKN 16 003 ISO	✓	×	EM90 D50 W25 L100 Z03 TPKN 1603		1.349

VCGT 2205/1604 ISO



KOD	Stok Stock	Inter Cooland	Kesici Uç Uyumluluğu / Insert Suitability		FİYAT PRICE
			ISO VCGT 2205/1604		
ST VCGT 22 001 ISO	✓	×	EM90 D32 W32 L250 Z02 VCGT 2205		1.787

QXMT 17 ISO



KOD	Stok Stock	Inter Cooland	Kesici Uç Uyumluluğu / Insert Suitability	FİYAT PRICE
			ISO QXMT 17	TL
ST QXMT 17 001 ISO	X	X	EM90 D25 W25 L150 Z02 QXMT 17	1.403
ST QXMT 17 003 ISO	✓	X	EM90 D28 W25 L160 Z02 QXMT 17	1.449
ST QXMT 17 004 ISO	X	X	EM90 D35 W25 L150 Z03 QXMT 17	1.575

APMT 1135 SNG



KOD	Stok Stock	Inter Cooland	Kesici Uç Uyumluluğu / Insert Suitability	FİYAT PRICE
			SNG APMT 1135	TL
ST APMT 11 001 SNG	✓	✓	EM90 D16 W15 L160 Z02 APMT 1135	1.326
ST APMT 11 002 SNG	✓	✓	EM90 D16 W16 L160 Z02 APMT 1135	1.326
ST APMT 11 003 SNG	✓	✓	EM90 D16 W16 L200 Z02 APMT 1135	1.458
ST APMT 11 004 SNG	✓	✓	EM90 D17 W16 L160 Z02 APMT 1135	1.417
ST APMT 11 005 SNG	✓	✓	EM90 D17 W16 L200 Z02 APMT 1135	1.458
ST APMT 11 006 SNG	✓	✓	EM90 D20 W20 L160 Z03 APMT 1135	1.458
ST APMT 11 007 SNG	✓	✓	EM90 D20 W20 L200 Z03 APMT 1135	1.638
ST APMT 11 008 SNG	✓	✓	EM90 D21 W20 L160 Z03 APMT 1135	1.550
ST APMT 11 009 SNG	✓	✓	EM90 D21 W20 L200 Z03 APMT 1135	1.726
ST APMT 11 010 SNG	✓	✓	EM90 D25 W25 L160 Z03 APMT 1135	1.550
ST APMT 11 011 SNG	✓	✓	EM90 D25 W25 L200 Z03 APMT 1135	1.768
ST APMT 11 012 SNG	✓	✓	EM90 D26 W25 L160 Z03 APMT 1135	1.550
ST APMT 11 013 SNG	✓	✓	EM90 D32 W32 L160 Z04 APMT 1135	1.726
ST APMT 11 014 SNG	✓	✓	EM90 D33 W32 L160 Z04 APMT 1135	1.768
ST APMT 11 016 SNG	✓	✓	EM90 D26 W25 L200 Z03 APMT 1135	1.768

APMT 1035 SNG



KOD	Stok Stock	Inter Cooland	Kesici Uç Uyumluluğu / Insert Suitability	FİYAT PRICE
			SNG APMT 1035	TL
ST APMT 10 002 SNG	X	✓	EM90 D20 W20 L100 Z03 APMT 1035 inter cooland	1.281
ST APMT 10 003 SNG	X	✓	EM90 D25 W25 L100 Z04 APMT 1035 inter cooland	1.368

LNGX 1104 SNG



KOD	Stok Stock	Inter Cooland	Kesici Uç Uyumluluğu / Insert Suitability	FİYAT PRICE
			SNG LNGX 1104	TL
ST LNGX 11 002 SNG	✓	✓	EM90 D20 W20 L160 Z02 LNGX 1104	1.550
ST LNGX 11 003 SNG	✓	✓	EM90 D25 W25 L160 Z03 LNGX 1104	1.726

ADKX 1204 FTTE



KOD	Stok Stock	Inter Cooland	Kesici Uç Uyumluluğu / Insert Suitability	FİYAT PRICE
			FTTE ADKX 1204	TL
ST ADKX 12 001 FTTE	✓	X	EM90 D12 W12 L80 Z01 ADKX 1204	1.105
ST ADKX 12 003 FTTE	X	X	EM90 D16 W16 L140 Z02 ADKX 1204	1.233
ST ADKX 12 007 FTTE	✓	X	EM90 D25 W25 L100 Z02 ADKX 1204	1.363
ST ADKX 12 008 FTTE	✓	X	EM90 D25 W25 L171 Z02 ADKX 1204	1.618
ST ADKX 12 010 FTTE	X	X	EM90 D25 W25 L100 Z03 ADKX 1204	1.403
ST ADKX 12 011 FTTE	✓	X	EM90 D32 W32 L111 Z03 ADKX 1204	1.660
ST ADKX 12 012 FTTE	X	X	EM90 D32 W32 L201 Z03 ADKX 1204	1.829
ST ADKX 12 013 FTTE	✓	X	EM90 D32 W32 L201 Z04 ADKX 1204	1.872

AOMT 1848 MTSBSH



KOD	Stok Stock	Inter Cooland	Kesici Uç Uyumluluğu / Insert Suitability	FİYAT PRICE
			MTSBSH AOMT 184804	TL
ST AOMT 18 001 MTSBSH	✓	X	EM90 D25 W25 L150 Z02 AOMT 184804	1.618
ST AOMT 18 002 MTSBSH	✓	X	EM90 D32 W32 L150 Z03 AOMT 184804	1.748

AOMT 1236 MTSBSH



KOD	Stok Stock	Inter Cooland	Kesici Uç Uyumluluğu / Insert Suitability	FİYAT PRICE
			MTSBSH AOMT 1236	TL
ST AOMT 12 001 MTSBSH	✓	✓	EM90 D16 W16 L150 Z02 AOMT 1236	1.363
ST AOMT 12 002 MTSBSH	✓	✓	EM90 D17 W16 L150 Z02 AOMT 1236	1.449
ST AOMT 12 003 MTSBSH	✓	✓	EM90 D20 W20 L150 Z03 AOMT 1236	1.532
ST AOMT 12 004 MTSBSH	✓	✓	EM90 D21 W20 L150 Z03 AOMT 1236	1.532
ST AOMT 12 005 MTSBSH	✓	✓	EM90 D25 W24 L150 Z04 AOMT 1236	1.575
ST AOMT 12 006 MTSBSH	✓	✓	EM90 D25 W25 L150 Z04 AOMT 1236	1.532
ST AOMT 12 007 MTSBSH	✓	✓	EM90 D32 W32 L150 Z04 AOMT 1236	1.660
ST AOMT 12 008 MTSBSH	✓	✓	EM90 D32 W32 L160 Z04 AOMT 1236	1.748
ST AOMT 12 010 MTSBSH	✓	✓	EM90 D20 W20 L200 Z03 AOMT 1236	1.748
ST AOMT 12 011 MTSBSH	✓	✓	EM90 D32 W32 L200 Z04 AOMT 1236	1.917
ST AOMT 12 012 MTSBSH	✓	✓	EM90 D25 W25 L200 Z04 AOMT 1236	1.657

APMT 11T3..



KOD	Stok Stock	Inter Cooland	Kesici Uç Uyumluluğu / Insert Suitability	FİYAT PRICE
			APMT 11T3..	TL
ST APMT 11 002	✓	✗	EM90 D16 W16 L120 Z02 APMT 11T3	1.153
ST APMT 11 003	✓	✗	EM90 D16 W16 L150 Z02 APMT 11T3	1.233
ST APMT 11 006	✓	✗	EM90 D18 W16 L100 Z02 APMT 11T3	1.194
ST APMT 11 008	✓	✗	EM90 D20 W20 L120 Z03 APMT 11T3	1.233
ST APMT 11 009	✓	✗	EM90 D20 W20 L150 Z03 APMT 11T3	1.363
ST APMT 11 014	✓	✗	EM90 D25 W25 L120 Z03 APMT 11T3	1.363
ST APMT 11 015	✓	✗	EM90 D25 W25 L150 Z03 APMT 11T3	1.449
ST APMT 11 019	✓	✗	EM90 D32 W32 L200 Z04 APMT 11T3	1.787

XO..0903 SCO



KOD	Stok Stock	Inter Cooland	Kesici Uç Uyumluluğu / Insert Suitability	FİYAT PRICE
			SCO XO.. 0903	TL
ST XO..09 001 SCO	✓	✓	EM90 D16 W16 L100 Z02 XO..0903	1.023
ST XO..09 002 SCO	✓	✗	EM90 D16 W16 L130 Z02 XO..0903	1.153
ST XO..09 003 SCO	✓	✗	EM90 D16 W16 L150 Z02 XO..0903	1.233
ST XO..09 005 SCO	✓	✓	EM90 D20 W20 L120 Z03 XO..0903	1.233
ST XO..09 006 SCO	✓	✗	EM90 D20 W20 L150 Z03 XO..0903	1.275
ST XO..09 007 SCO	✓	✗	EM90 D20 W20 L200 Z03 XO..0903	1.575
ST XO..09 008 SCO	✓	✗	EM90 D25 W25 L150 Z03 XO..0903	1.492

XOMX 1204 SCO



XNEX 0403 SCO



APKT 1604 ZCC



KOD	Stok Stock	Inter Cooland	Kesici Uç Uyumluluğu / Insert Suitability		FIYAT PRICE
			SCO XOMX 1204..		TL
ST XOMX 12 001 SCO	✓	X	EM90 D16 W16 L120 Z01 XOMX 1204		1.023
ST XOMX 12 002 SCO	✓	X	EM90 D16 W16 L150 Z01 XOMX 1204		1.105
ST XOMX 12 003 SCO	✓	X	EM90 D20 W20 L100 Z02 XOMX 1204		1.064
ST XOMX 12 004 SCO	✓	X	EM90 D20 W20 L120 Z02 XOMX 1204		1.105
ST XOMX 12 004 SCO (S)	✓	✓	EM90 D20 W20 L120 Z02 XOMX 1204 inter cooland		1.275
ST XOMX 12 005 SCO	✓	X	EM90 D20 W20 L150 Z02 XOMX 1204		1.275
ST XOMX 12 006 SCO	✓	X	EM90 D22 W20 L150 Z02 XOMX 1204		1.322
ST XOMX 12 007 SCO	✓	X	EM90 D25 W25 L120 Z03 XOMX 1204		1.403
ST XOMX 12 007 SCO (S)	✓	✓	EM90 D25 W25 L120 Z03 XOMX 1204 inter cooland		1.575
ST XOMX 12 008 SCO	✓	X	EM90 D25 W25 L150 Z03 XOMX 1204		1.492
ST XOMX 12 008 SCO (S)	✓	✓	EM90 D25 W25 L150 Z03 XOMX 1204 inter cooland		1.618
ST XOMX 12 009 SCO	✓	X	EM90 D32 W25 L150 Z04 XOMX 1204		1.618
ST XOMX 12 009 SCO (S)	✓	✓	EM90 D32 W25 L150 Z04 XOMX 1204 inter cooland		1.829
ST XOMX 12 010 SCO	✓	X	EM90 D25 W25 L100 Z03 XOMX 1204		1.322
ST XOMX 12 011 SCO	✓	X	EM90 D20 W20 L200 Z02 XOMX 1204		1.492
ST XOMX 12 012 SCO	✓	X	EM90 D25 W25 L200 Z03 XOMX 1204		1.660
ST XOMX 12 013 SCO	✓	X	EM90 D32 W25 L200 Z04 XOMX 1204		1.917

KOD	Stok Stock	Inter Cooland	Kesici Uç Uyumluluğu / Insert Suitability		FIYAT PRICE
			SCO XNEX 0403		TL
ST XNEX 04 001 SCO	✓	✓	EM90 D18 W16 L150 Z02 XNEX 0403		1.748
ST XNEX 04 002 SCO	✓	✓	EM90 D18 W16 L200 Z02 XNEX 0403		1.787
ST XNEX 04 003 SCO	✓	✓	EM90 D20 W20 L150 Z03 XNEX 0403		1.872
ST XNEX 04 004 SCO	✓	✓	EM90 D21 W20 L150 Z03 XNEX 0403		1.917
ST XNEX 04 005 SCO	✓	✓	EM90 D21 W20 L200 Z03 XNEX 0403		2.002
ST XNEX 04 006 SCO	✓	✓	EM90 D25 W25 L150 Z04 XNEX 0403		2.044
ST XNEX 04 007 SCO	✓	✓	EM90 D26 W25 L150 Z04 XNEX 0403		2.085
ST XNEX 04 008 SCO	✓	✓	EM90 D32 W32 L150 Z04 XNEX 0403		2.127
ST XNEX 04 009 SCO	✓	✓	EM90 D25 W25 L200 Z04 XNEX 0403		2.213
ST XNEX 04 010 SCO	✓	✓	EM90 D26 W25 L200 Z04 XNEX 0403		2.213
ST XNEX 04 011 SCO	✓	✓	EM90 D32 W32 L200 Z04 XNEX 0403		2.382

KOD	Stok Stock	Inter Cooland	Kesici Uç Uyumluluğu / Insert Suitability		FIYAT PRICE
			ZCC APKT 1604..		TL
ST APKT 16 001 ZCC	✓	X	EM90 D25 W25 L170 Z02 APKT 1604		1.506
ST APKT 16 002 ZCC	✓	X	EM90 D26 W25 L200 Z02 APKT 1604		1.682
ST APKT 16 003 ZCC	✓	X	EM90 D32 W32 L170 Z03 APKT 1604		1.682
ST APKT 16 004 ZCC	✓	X	EM90 D26 W25 L250 Z02 APKT 1604		1.901
ST APKT 16 026 ZCC	✓	X	EM90 D33 W32 L200 Z03 APKT 1604		1.857
ST APKT 16 027 ZCC	✓	X	EM90 D33 W32 L250 Z03 APKT 1604		2.035
ST APKT 16 028 ZCC	✓	X	EM90 D33 W32 L300 Z03 APKT 1604		2.211
ST APKT 16 029 ZCC	✓	X	EM90 D33 W32 L350 Z03 APKT 1604		2.564
ST APKT 16 030 ZCC	✓	X	EM90 D33 W32 L400 Z03 APKT 1604		3.227

APKT 11T3 ZCC



KOD	Stok Stock	Inter Cooland	Kesici Uç Uyumluluğu / Insert Suitability		FİYAT PRICE
			ZCC APKT 11T3		TL
ST APKT 11 001 ZCC	✓	X	EM90 D16 W16 L160 Z02 APKT 11T3		1.326
ST APKT 11 001 ZCC (S)	✓	✓	EM90 D16 W16 L160 Z02 APKT 11T3 inter cooland		1.550
ST APKT 11 002 ZCC	✓	X	EM90 D16 W16 L200 Z02 APKT 11T3		1.458
ST APKT 11 002 ZCC (S)	✓	✓	EM90 D16 W16 L200 Z02 APKT 11T3 inter cooland		1.682
ST APKT 11 003 ZCC	✓	X	EM90 D17 W16 L160 Z02 APKT 11T3		1.326
ST APKT 11 004 ZCC	✓	X	EM90 D17 W16 L200 Z02 APKT 11T3		1.417
ST APKT 11 005 ZCC	✓	X	EM90 D17 W16 L250 Z02 APKT 11T3		1.592
ST APKT 11 006 ZCC	✓	X	EM90 D18 W16 L160 Z02 APKT 11T3		1.326
ST APKT 11 007 ZCC	✓	✓	EM90 D20 W20 L160 Z03 APKT 11T3		1.417
ST APKT 11 007 ZCC (S)	✓	✓	EM90 D20 W20 L160 Z03 APKT 11T3 inter cooland		1.638
ST APKT 11 008 ZCC	✓	X	EM90 D21 W20 L160 Z03 APKT 11T3		1.458
ST APKT 11 009 ZCC	✓	X	EM90 D21 W20 L200 Z03 APKT 11T3		1.550
ST APKT 11 010 ZCC	✓	X	EM90 D21 W20 L250 Z03 APKT 11T3		1.726
ST APKT 11 011 ZCC	✓	X	EM90 D25 W25 L160 Z03 APKT 11T3		1.682
ST APKT 11 012 ZCC	✓	X	EM90 D26 W25 L160 Z03 APKT 11T3		1.726
ST APKT 11 013 ZCC	✓	X	EM90 D26 W25 L200 Z03 APKT 11T3		1.726
ST APKT 11 014 ZCC	✓	X	EM90 D26 W25 L250 Z03 APKT 11T3		1.901
ST APKT 11 015 ZCC	✓	✓	EM90 D20 W20 L200 Z03 APKT 11T3		1.639
ST APKT 11 016 ZCC	✓	X	EM90 D16 W16 L100 Z02 APKT 11T3		1.198
ST APKT 11 017 ZCC	✓	X	EM90 D20 W20 L120 Z03 APKT 11T3		1.281
ST APKT 11 018 ZCC	✓	X	EM90 D25 W25 L120 Z03 APKT 11T3		1.550
ST APKT 11 019 ZCC	✓	X	EM90 D25 W25 L200 Z03 APKT 11T3		1.768
ST APKT 11 020 ZCC	✓	X	EM90 D32 W32 L200 Z04 APKT 11T3		1.946

APKT 0702 ZCC



KOD	Stok Stock	Inter Cooland	Kesici Uç Uyumluluğu / Insert Suitability		FİYAT PRICE
			ZCC APKT 0702		TL
ST AP..07 001 ZCC	✓	X	EM90 D10 W10 L130 Z02 AP.0702 ZCC		1.281
ST AP..07 002 ZCC	✓	X	EM90 D12 W10 L130 Z02 AP.0702 ZCC		1.326
ST AP..07 003 ZCC	✓	X	EM90 D12 W12 L130 Z02 AP.0702 ZCC		1.326
ST AP..07 004 ZCC	✓	X	EM90 D14 W12 L130 Z03 AP.0702 ZCC		1.458
ST AP..07 007 ZCC	✓	X	EM90 D10 W9 L130 Z02 AP.0702		1.281
ST AP..07 008 ZCC	✓	X	EM90 D12 W10 L150 Z02 AP.0702		1.391
ST AP..07 009 ZCC	✓	X	EM90 D12 W12 L150 Z02 AP.0702		1.391
ST AP..07 010 ZCC	✓	X	EM90 D14 W12 L150 Z03 AP.0702		1.514

ANGX 1105 ZCC



KOD	Stok Stock	Inter Cooland	Kesici Uç Uyumluluğu / Insert Suitability	FIYAT PRICE
			ZCC ANGX 1105	TL
ST ANGX 11 001 ZCC	✓	✓	EM90 D25 W25 L150 Z02 ANGX 1105	1.550
ST ANGX 11 002 ZCC	✓	✓	EM90 D32 W32 L150 Z03 ANGX 1105	1.726
ST ANGX 11 003 ZCC	x	✓	EM90 D40 W32 L150 Z04 ANGX 1105	1.901

LNKT 0804 ZCC



KOD	Stok Stock	Inter Cooland	Kesici Uç Uyumluluğu / Insert Suitability	FIYAT PRICE
			ZCC LNKT 0804	TL
ST LNKT 08 001 ZCC	✓	✓	EM90 D20 W20 L160 Z02 LNKT 0804	1.506
ST LNKT 08 002 ZCC	✓	✓	EM90 D25 W25 L160 Z03 LNKT 0804	1.682
ST LNKT 08 003 ZCC	✓	✓	EM90 D32 W32 L160 Z04 LNKT 0804	1.768

WNHU 0604 ZCC



KOD	Stok Stock	Inter Cooland	Kesici Uç Uyumluluğu / Insert Suitability	FIYAT PRICE
			ZCC WNHU 0604	TL
ST WNHU 06 001 ZCC	✓	✓	EM90 D25 W25 L160 Z02 WNHU 0604 ZCC	1.506
ST WNHU 06 002 ZCC	✓	✓	EM90 D26 W25 L200 Z02 WNHU 0604 ZCC	1.682
ST WNHU 06 003 ZCC	✓	✓	EM90 D32 W32 L160 Z03 WNHU 0604 ZCC	1.726

ADMT 1204 WLTR



KOD	Stok Stock	Inter Cooland	Kesici Uç Uyumluluğu / Insert Suitability		FİYAT PRICE TL
			WLTR ADMT 1204		
ST ADMT 12 001 WLTR	✓	✗	EM90 D20 W20 L120 Z02 ADMT 1204		1.338
ST ADMT 12 001 WLTR (S)	✓	✓	EM90 D20 W20 L120 Z02 ADMT 1204 inter cooland		1.449
ST ADMT 12 002 WLTR	✓	✗	EM90 D20 W20 L150 Z02 ADMT 1204		1.365
ST ADMT 12 003 WLTR	✓	✗	EM90 D25 W25 L120 Z03 ADMT 1204		1.575
ST ADMT 12 003 WLTR (S)	✓	✓	EM90 D25 W25 L120 Z03 ADMT 1204 inter cooland		1.674
ST ADMT 12 004 WLTR	✓	✗	EM90 D25 W25 L150 Z03 ADMT 1204		1.618
ST ADMT 12 005 WLTR	✓	✗	EM90 D30 W25 L120 Z03 ADMT 1204		1.700
ST ADMT 12 006 WLTR	✓	✗	EM90 D30 W25 L150 Z03 ADMT 1204		1.787
ST ADMT 12 007 WLTR	✓	✗	EM90 D32 W32 L150 Z04 ADMT 1204		1.829
ST ADMT 12 007 WLTR (S)	✓	✓	EM90 D32 W32 L150 Z04 ADMT 1204 inter cooland		1.904
ST ADMT 12 008 WLTR	✓	✗	EM90 D40 W32 L120 Z04 ADMT 1204		1.917
ST ADMT 12 009 WLTR	✓	✗	EM90 D40 W32 L150 Z04 ADMT 1204		2.002

ADMT 10T3 WLTR



KOD	Stok Stock	Inter Cooland	Kesici Uç Uyumluluğu / Insert Suitability		FİYAT PRICE TL
			WLTR ADMT 10T3..		
ST ADMT 10 002 WLTR	✓	✗	EM90 D20 W20 L120 Z03 ADMT 10T3		1.363
ST ADMT 10 003 WLTR	✓	✗	EM90 D25 W25 L120 Z03 ADMT 10T3		1.449

ADMT 0803 WLTR



KOD	Stok Stock	Inter Cooland	Kesici Uç Uyumluluğu / Insert Suitability		FİYAT PRICE TL
			WLTR ADMT 0803		
ST ADMT 08 001 WLTR	✓	✗	EM90 D16 W16 L150 Z02 ADMT 0803		1.153
ST ADMT 08 001 WLTR (S)	✓	✓	EM90 D16 W16 L150 Z02 ADMT 0803 inter cooland		1.275
ST ADMT 08 002 WLTR	✓	✗	EM90 D20 W16 L200 Z03 ADMT 0803		1.575
ST ADMT 08 003 WLTR	✓	✗	EM90 D20 W20 L150 Z03 ADMT 0803		1.363
ST ADMT 08 004 WLTR	✓	✗	EM90 D20 W20 L200 Z03 ADMT 0803		1.575
ST ADMT 08 005 WLTR	✓	✗	EM90 D26 W25 L150 Z03 ADMT 0803		1.575
ST ADMT 08 006 WLTR	✓	✗	EM90 D26 W25 L200 Z03 ADMT 0803		1.700

AP..0903 WLTR



KOD	Stok Stock	Inter Cooland	Kesici Uç Uyumluluğu / Insert Suitability	FIYAT PRICE
			WLTR AP..0903	TL
ST AP..09 002 WLTR	✓	X	EM90 D16 W16 L120 Z02 AP.0903	1.153
ST AP..09 003 WLTR	✓	X	EM90 D16 W16 L150 Z02 AP.0903	1.233
ST AP..09 004 WLTR	✓	X	EM90 D16 W16 L200 Z02 AP.0903	1.363
ST AP..09 005 WLTR	✓	X	EM90 D20 W20 L120 Z03 AP.0903	1.275
ST AP..09 007 WLTR	✓	X	EM90 D20 W20 L200 Z03 AP.0903	1.618

LNHU 0904 WLTR



KOD	Stok Stock	Inter Cooland	Kesici Uç Uyumluluğu / Insert Suitability	FIYAT PRICE
			WLTR LNHU 0904	TL
ST LNHU 09 001 WLTR	✓	✓	EM90 D20 W20 L120 Z03 LNHU 0904	1.275
ST LNHU 09 002 WLTR	✓	✓	EM90 D20 W20 L150 Z03 LNHU 0904	1.403
ST LNHU 09 003 WLTR	✓	✓	EM90 D25 W25 L120 Z04 LNHU 0904	1.492
ST LNHU 09 004 WLTR	✓	✓	EM90 D25 W25 L150 Z03 LNHU 0904	1.618
ST LNHU 09 005 WLTR	✓	✓	EM90 D32 W32 L120 Z05 LNHU 0904	1.787

LNHU 1306 WLTR



KOD	Stok Stock	Inter Cooland	Kesici Uç Uyumluluğu / Insert Suitability	FIYAT PRICE
			WLTR LNHU 1306	TL
ST LNHU 13 001 WLTR	✓	✓	EM90 D30 W25 L150 Z03 LNHU 1306	1.618
ST LNHU 13 003 WLTR	✓	✓	EM90 D40 W32 L150 Z04 LNHU 1306	1.872
ST LNHU 13 004 WLTR	✓	✓	EM90 D40 W40 L200 Z04 LNHU 1306	2.255

AXMT 1235 SMTM



KOD	Stok Stock	Inter Cooland	Kesici Uç Uyumluluğu / Insert Suitability		FIYAT PRICE
			SMTM AXMT 1235		TL
ST AXMT 1235 001 SMTM	X	X	EM90 D12 W12 L100 Z01 AXMT 1235		1.105
ST AXMT 1235 002 SMTM	X	X	EM90 D14 W12 L100 Z01 AXMT 1235		1.233
ST AXMT 1235 003 SMTM	X	X	EM90 D16 W16 L100 Z01 AXMT 1235		1.363
ST AXMT 1235 004 SMTM	X	X	EM90 D18 W16 L100 Z02 AXMT 1235		1.403
ST AXMT 1235 005 SMTM	X	X	EM90 D20 W20 L100 Z03 AXMT 1235		1.449

AXMT 0602 SMTM



KOD	Stok Stock	Inter Cooland	Kesici Uç Uyumluluğu / Insert Suitability		FIYAT PRICE
			SMTM AXMT 0602		TL
ST AXMT 06 001 SMTM	✓	X	EM90 D10 W10 L75 Z02 AXMT 0602		1.233
ST AXMT 06 002 SMTM	✓	X	EM90 D12 W12 L120 Z02 AXMT 0602		1.233
ST AXMT 06 003 SMTM	✓	X	EM90 D12 W12 L90 Z03 AXMT 0602		1.275
ST AXMT 06 004 SMTM	✓	X	EM90 D14 W16 L100 Z03 AXMT 0602		1.492

APKT 1003 PLBT



KOD	Stok Stock	Inter Cooland	Kesici Uç Uyumluluğu / Insert Suitability		FIYAT PRICE
			PLBT APKT 1003..		TL
ST APKT 10 001 PLT	X	X	EM90 D16 W16 L120 Z02 APKT 1003		1.275
ST APKT 10 002 PLT	✓	X	EM90 D16 W16 L150 Z02 APKT 1003		1.363
ST APKT 10 003 PLT	X	X	EM90 D20 W20 L120 Z03 APKT 1003		1.403
ST APKT 10 004 PLT	✓	X	EM90 D20 W20 L150 Z03 APKT 1003		1.449
ST APKT 10 005 PLT	X	X	EM90 D25 W25 L120 Z03 APKT 1003		1.575
ST APKT 10 006 PLT	✓	X	EM90 D25 W25 L150 Z03 APKT 1003		1.660

XPET 0602 PLBT



KOD	Stok Stock	Inter Cooland	Kesici Uç Uyumluluğu / Insert Suitability		FİYAT PRICE
			PLBT XPET 0602		TL
ST XPET 06 001 PLBT	✓	✗	EM90 D08 W08 L100 Z01	XPET 0602	1.023
ST XPET 06 002 PLBT	✓	✗	EM90 D08 W08 L120 Z01	XPET 0602	1.023
ST XPET 06 003 PLBT	✓	✗	EM90 D10 W9 L120 Z02	XPET 0602	1.105
ST XPET 06 004 PLBT	✓	✗	EM90 D10 W10 L100 Z02	XPET 0602	1.105
ST XPET 06 006 PLBT	✓	✗	EM90 D12 W12 L100 Z03	XPET 0602	1.233
ST XPET 06 007 PLBT	✓	✗	EM90 D12 W11 L120 Z03	XPET 0602	1.233
ST XPET 06 008 PLBT	✓	✗	EM90 D12 W12 L120 Z03	XPET 0602	1.233
ST XPET 06 009 PLBT	✓	✗	EM90 D14 W12 L140 Z03	XPET 0602	1.363
ST XPET 06 010 PLBT	✓	✗	EM90 D16 W12 L160 Z04	XPET 0602	1.532

LN..0804 I



KOD	Stok Stock	Inter Cooland	Kesici Uç Uyumluluğu / Insert Suitability		FİYAT PRICE
			I LNMT 0804		TL
ST LN..08 001 I	✓	✗	EM90 D16 W16 L120 Z02	LNMT 0804	1.618
ST LN..08 002 I	✓	✗	EM90 D18 W20 L120 Z02	LNMT 0804	1.660
ST LN..08 003 I	✓	✗	EM90 D20 W20 L120 Z03	LNMT 0804	1.748
ST LN..08 005 I	✓	✗	EM90 D25 W25 L150 Z04	LNMT 0804	1.958
ST LN..08 008 I	✓	✗	EM90 D30 W25 L150 Z04	LNMT 0804	1.934
ST LN..08 009 I	✓	✗	EM90 D32 W32 L200 Z04	LNMT 0804	2.170

AN..1205 I



KOD	Stok Stock	Inter Cooland	Kesici Uç Uyumluluğu / Insert Suitability		FİYAT PRICE
			I ANKX 1205		TL
ST ANKX 12 002 I	✗	✗	EM90 D30 W25 L150 Z02	ANKX 1205	1.449
ST ANKX 12 003 I	✓	✓	EM90 D30 W25 L120 Z03	ANKX 1205	1.403
ST ANKX 12 005 I	✓	✓	EM90 D35 W32 L120 Z03	ANKX 1205	1.449
ST ANKX 12 006 I	✓	✓	EM90 D35 W32 L150 Z03	ANKX 1205	1.532
ST ANKX 12 007 I	✗	✗	EM90 D30 W30 L110 Z03	ANKX 1205	1.449
ST ANKX 12 008 I	✓	✓	EM90 D30 W25 L200 Z03	ANKX 1205	1.449

TP..1003 I



KOD	Stok Stock	Inter Cooland	Kesici Uç Uyumluluğu / Insert Suitability		FİYAT PRICE
			I TPKT 1003		TL
ST TPKT 10 001 I	✓	✓	EM90 D25 W25 L120 Z03 TPKT 1003		1.917
ST TPKT 10 002 I	✓	✓	EM90 D25 W25 L150 Z03 TPKT 1003		2.044
ST TPKT 10 004 I	✓	✓	EM90 D32 W32 L150 Z04 TPKT 1003		2.340

ADKT 1505 I



KOD	Stok Stock	Inter Cooland	Kesici Uç Uyumluluğu / Insert Suitability		FİYAT PRICE
			I ADKT 1505		TL
ST ADKT 15 001 I	✓	✓	EM90 D25 W25 L150 Z02 ADKT 1505		1.403
ST ADKT 15 002 I	✓	✓	EM90 D32 W32 L150 Z03 ADKT 1505		1.532
ST ADKT 15 003 I	✓	✓	EM90 D40 W32 L150 Z04 ADKT 1505		1.618

ANKX 0904 I



KOD	Stok Stock	Inter Cooland	Kesici Uç Uyumluluğu / Insert Suitability		FİYAT PRICE
			I ANKX 0904		TL
ST ANKX 09 001 I	✓	✓	EM90 D16 W16 L150 Z02 ANKX 0904		1.403
ST ANKX 09 002 I	✓	✓	EM90 D20 W20 L150 Z02 ANKX 0904		1.449
ST ANKX 09 004 I	✓	✓	EM90 D20 W20 L150 Z03 ANKX 0904		1.449
ST ANKX 09 005 I	✓	✓	EM90 D25 W25 L150 Z03 ANKX 0904		1.575
ST ANKX 09 006 I	✓	✓	EM90 D32 W32 L150 Z04 ANKX 0904		1.787

TCKT 0703 I



KOD	Stok Stock	Inter Cooland	Kesici Uç Uyumluluğu / Insert Suitability		FIYAT PRICE
			I TCKT 0703		TL
ST TCKT 07 001 I	✓	✓	EM90 D16 W16 L150 Z02 TCKT 0703		1.449
ST TCKT 07 002 I	✓	✓	EM90 D20 W20 L150 Z03 TCKT 0703		1.532

LNGU 1104 KNNMTL



KOD	Stok Stock	Inter Cooland	Kesici Uç Uyumluluğu / Insert Suitability		FIYAT PRICE
			KNNMTL LNGU 110408		TL
ST LNGU 11 001 KNM	✓	✓	EM90 D16 W16 L120 Z02 LNGU 110408		1.275
ST LNGU 11 002 KNM	✓	✓	EM90 D20 W20 L120 Z02 LNGU 110408		1.403
ST LNGU 11 003 KNM	✓	✓	EM90 D25 W25 L120 Z03 LNGU 110408		1.575
ST LNGU 11 004 KNM	✓	✓	EM90 D25 W25 L150 Z03 LNGU 110408		1.660
ST LNGU 11 005 KNM	✓	✓	EM90 D16 W16 L150 Z02 LNGU 110408		1.403
ST LNGU 11 006 KNM	✓	✓	EM90 D20 W20 L150 Z02 LNGU 110408		1.492

EDPT 1404 KNNMTL



KOD	Stok Stock	Inter Cooland	Kesici Uç Uyumluluğu / Insert Suitability		FIYAT PRICE
			KNNMTL EDPT 1404		TL
ST EDPT 14 001 KNM	✓	X	EM90 D20 W20 L120 Z02 EDPT 1404		1.492
ST EDPT 14 002 KNM	✓	X	EM90 D20 W20 L150 Z02 EDPT 1404		1.575
ST EDPT 14 003 KNM	✓	X	EM90 D25 W25 L120 Z03 EDPT 1404		1.700
ST EDPT 14 004 KNM	✓	X	EM90 D25 W25 L150 Z03 EDPT 1404		1.829

EDPT 10T3/1805 KNNMTL



KOD	Stok Stock	Inter Cooland	Kesici Uç Uyumluluğu / Insert Suitability		FİYAT PRICE
			KNNMTL EDPT 10T3/1805		TL
ST EDPT 10 001 KNM	✓	✗	EM90 D16 W16 L150 Z02	EDPT 10T3	1.492
ST EDPT 10 002 KNM	✓	✗	EM90 D18 W16 L150 Z02	EDPT 10T3	1.532
ST EDPT 10 003 KNM	✓	✗	EM90 D20 W20 L150 Z03	EDPT 10T3	1.575
ST EDPT 10 004 KNM	✓	✗	EM90 D25 W25 L150 Z03	EDPT 10T3	1.829
ST EDPT 10 005 KNM	✓	✗	EM90 D17 W16 L150 Z02	EDPT 10T3	1.575
ST EDPT 10 006 KNM	✓	✗	EM90 D21 W20 L150 Z03	EDPT 10T3	1.618
ST EDPT 10 007 KNM	✓	✗	EM90 D16 W14 L120 Z02	EDPT 10T3	1.449
ST EDPT 10 008 KNM	✓	✗	EM90 D17 W16 L200 Z02	EDPT 10T3	1.660
ST EDPT 10 009 KNM	✓	✗	EM90 D22 W20 L200 Z03	EDPT 10T3	1.787
ST EDPT 10 010 KNM	✓	✗	EM90 D16 W16 L120 Z02	EDPT 10T3	1.322
ST EDPT 10 011 KNM	✓	✗	EM90 D22 W20 L150 Z03	EDPT 10T3	1.660
ST EDPT 18 005 KNM	✓	✗	EM90 D25 W25 L200 Z02	EDPT 1805	1.872
ST EDPT 18 006 KNM	✓	✗	EM90 D32 W32 L200 Z03	EDPT 1805	2.044

LNMX 1006 KRLY



KOD	Stok Stock	Inter Cooland	Kesici Uç Uyumluluğu / Insert Suitability		FİYAT PRICE
			KRLY LNMX 1006		TL
ST LNMX 10 001 KRLY	✓	✓	EM90 D16 W16 L90 Z01	LNMX 1006	937
ST LNMX 10 003 KRLY	✓	✓	EM90 D18 W16 L120 Z02	LNMX 1006	1.170
ST LNMX 10 005 KRLY	✓	✓	EM90 D20 W20 L100 Z02	LNMX 1006	1.275
ST LNMX 10 006 KRLY	✓	✓	EM90 D20 W20 L150 Z02	LNMX 1006	1.322
ST LNMX 10 008 KRLY	✓	✓	EM90 D25 W25 L115 Z02	LNMX 1006	1.532
ST LNMX 10 009 KRLY	✓	✓	EM90 D25 W25 L115 Z03	LNMX 1006	1.575
ST LNMX 10 010 KRLY	✓	✓	EM90 D25 W25 L150 Z03	LNMX 1006	1.618
ST LNMX 10 012 KRLY	✓	✓	EM90 D32 W32 L125 Z04	LNMX 1006	1.660
ST LNMX 10 013 KRLY	✓	✓	EM90 D40 W32 L130 Z04	LNMX 1006	1.829
ST LNMX 10 014 KRLY	✓	✓	EM90 D40 W32 L130 Z05	LNMX 1006	1.999
ST LNMX 10 016 KRLY	✓	✓	EM90 D32 W32 L200 Z04	LNMX 1006	1.853
ST LNMX 10 017 KRLY	✓	✓	EM90 D26 W25 L200 Z03	LNMX 1006	1.829
ST LNMX 10 018 KRLY	✓	✓	EM90 D32 W32 L150 Z04	LNMX 1006	1.693

XNKT 0604 KRLY



KOD	Stok Stock	Inter Cooland	Kesici Uç Uyumluluğu / Insert Suitability		FİYAT PRICE
			KRLY XNKT 0604/0805		TL
ST XNKT 06 001 KRLY	✓	✓	EM90 D18 W20 L150 Z02	XNKT 0604	1.618
ST XNKT 06 002 KRLY	✓	✓	EM90 D20 W20 L150 Z02	XNKT 0604	1.660
ST XNKT 06 003 KRLY	✓	✓	EM90 D22 W20 L150 Z02	XNKT 0604	1.787
ST XNKT 06 004 KRLY	✓	✓	EM90 D25 W25 L150 Z03	XNKT 0604	1.958
ST XNKT 06 005 KRLY	✓	✓	EM90 D26 W25 L150 Z03	XNKT 0604	2.002
ST XNKT 06 006 KRLY	✓	✓	EM90 D32 W32 L150 Z04	XNKT 0604	2.213
ST XNKT 06 007 KRLY	✓	✓	EM90 D21 W20 L200 Z02	XNKT 0604	2.213
ST XNKT 06 010 KRLY	✓	✓	EM90 D25 W25 L200 Z03	XNKT 0604	2.297
ST XNKT 06 011 KRLY	✓	✓	EM90 D26 W25 L200 Z03	XNKT 0604	2.340
ST XNKT 06 012 KRLY	✓	✓	EM90 D21 W20 L150 Z02	XNKT 0604	1.814
ST XNKT 08 008 KRLY	✓	✓	EM90 D32 W32 L150 Z03	XNKT 0805	2.382
ST XNKT 08 009 KRLY	✓	✓	EM90 D42 W32 L150 Z04	XNKT 0805	2.682
ST XNKT 08 010 KRLY	✓	✓	EM90 D32 W32 L200 Z03	XNKT 0805	2.467
ST XNKT 08 012 KRLY	✓	✓	EM90 D40 W32 L200 Z04	XNKT 0805	2.597

APMT 11T308 KRLY



KOD	Stok Stock	Inter Cooland	Kesici Uç Uyumluluğu / Insert Suitability		FIYAT PRICE
			KRLY APMT 11T3		TL
ST APMT 11 001 KRLY	✓	X	EM90 D16 W16 L120 Z02 APMT 11T3		937
ST APMT 11 002 KRLY	✓	X	EM90 D16 W16 L150 Z02 APMT 11T3		1.233
ST APMT 11 003 KRLY	✓	X	EM90 D16 W16 L200 Z02 APMT 11T3		1.403
ST APMT 11 004 KRLY	✓	X	EM90 D17 W16 L120 Z02 APMT 11T3		978
ST APMT 11 005 KRLY	✓	X	EM90 D20 W20 L120 Z03 APMT 11T3		1.213
ST APMT 11 006 KRLY	✓	X	EM90 D21 W20 L120 Z03 APMT 11T3		1.233
ST APMT 11 007 KRLY	✓	X	EM90 D22 W20 L120 Z03 APMT 11T3		1.233
ST APMT 11 008 KRLY	✓	X	EM90 D20 W20 L200 Z03 APMT 11T3		1.492
ST APMT 11 009 KRLY	✓	X	EM90 D21 W20 L200 Z03 APMT 11T3		1.532
ST APMT 11 010 KRLY	✓	X	EM90 D25 W25 L150 Z03 APMT 11T3		1.492
ST APMT 11 011 KRLY	✓	X	EM90 D18 W16 L120 Z02 APMT 11T3		978
ST APMT 11 012 KRLY	✓	X	EM90 D20 W20 L150 Z03 APMT 11T3		1.363
ST APMT 11 013 KRLY	✓	X	EM90 D17 W16 L150 Z02 APMT 11T3		1.275
ST APMT 11 014 KRLY	✓	X	EM90 D21 W20 L150 Z03 APMT 11T3		1.403
ST APMT 11 015 KRLY	✓	X	EM90 D22 W20 L150 Z03 APMT 11T3		1.403

ST APKT 1003 YG



KOD	Stok Stock	Inter Cooland	Kesici Uç Uyumluluğu / Insert Suitability		FIYAT PRICE
			YG APKT 1003		TL
ST APKT 10 004 YG	✓	X	EM90 D17 W16 L200 Z02 APKT 1003 YG		1.365
ST APKT 10 005 YG	✓	X	EM90 D17 W16 L300 Z02 APKT 1003 YG		1.829
ST APKT 10 006 YG	✓	X	EM90 D21 W20 L200 Z02 APKT 1003 YG		1.700
ST APKT 10 007 YG	✓	X	EM90 D21 W20 L300 Z02 APKT 1003 YG		1.958

R390 11T3 SNDVK



KOD	Stok Stock	Inter Cooland	Kesici Uç Uyumluluğu / Insert Suitability		FIYAT PRICE
			SNDVK R390-11T3		TL
ST R390 11 001 SNDVK	✓	X	EM90 D16 W16 L150 Z02 R390 11T3		1.194
ST R390 11 001 SNDVK (S)	✓	✓	EM90 D16 W16 L150 Z02 R390 11T3 inter cooland		1.363
ST R390 11 002 SNDVK	✓	X	EM90 D20 W20 L150 Z03 R390 11T3		1.275
ST R390 11 002 SNDVK (S)	✓	✓	EM90 D20 W20 L150 Z03 R390 11T3 inter cooland		1.449
ST R390 11 003 SNDVK	✓	X	EM90 D25 W25 L150 Z03 R390 11T3		1.363
ST R390 11 003 SNDVK (S)	✓	✓	EM90 D25 W25 L150 Z03 R390 11T3 inter cooland		1.575
ST R390 11 004 SNDVK	✓	X	EM90 D20 W20 L100 Z03 R390 11T3		1.057
ST R390 11 005 SNDVK	✓	X	EM90 D16 W16 L100 Z02 R390 11T3		937
ST R390 11 006 SNDVK	✓	X	EM90 D25 W25 L100 Z03 R390 11T3		1.122

R390 1704 SNDVK



KOD	Stok Stock	Inter Cooland	Kesici Uç Uyumluluğu / Insert Suitability		FİYAT PRICE
			SNDVK R390-1704		TL
ST R390 17 001 SNDVK	✓	✗	EM90 D25 W25 L150 Z02 R390 1704		1.492
ST R390 17 001 SNDVK (S)	✓	✓	EM90 D25 W25 L150 Z02 R390 1704 inter cooland		1.660
ST R390 17 002 SNDVK	✓	✗	EM90 D32 W32 L150 Z03 R390 1704		1.748
ST R390 17 002 SNDVK (S)	✓	✓	EM90 D32 W32 L150 Z03 R390 1704 inter cooland		1.958
ST R390 17 003 SNDVK	✓	✗	EM90 D40 W25 L150 Z04 R390 1704		1.917

ANHG 1005 VNDRT



KOD	Stok Stock	Inter Cooland	Kesici Uç Uyumluluğu / Insert Suitability		FİYAT PRICE
			VNDRT ANHG 1005		TL
ST ANHG 10 001 VNDRT	✓	✓	EM90 D20 W20 L90 Z02 ANHG 1005		1.233
ST ANHG 10 002 VNDRT	✓	✓	EM90 D20 W20 L120 Z02 ANHG 1005		1.363
ST ANHG 10 003 VNDRT	✓	✓	EM90 D20 W20 L150 Z02 ANHG 1005		1.449
ST ANHG 10 004 VNDRT	✓	✓	EM90 D25 W25 L100 Z03 ANHG 1005		1.618
ST ANHG 10 005 VNDRT	✓	✓	EM90 D25 W25 L150 Z03 ANHG 1005		1.787
ST ANHG 10 006 VNDRT	✓	✓	EM90 D32 W32 L110 Z03 ANHG 1005		1.872

LNGX 1205 PRMT/VNDRT



KOD	Stok Stock	Inter Cooland	Kesici Uç Uyumluluğu / Insert Suitability		FİYAT PRICE
			PRMT/VNDRT LNGX 1205		TL
ST LNGX 12 001 VNDRT	✓	✗	EM90 D25 W25 L150 Z02 LNGX 1205		1.575
ST LNGX 12 002 VNDRT	✓	✗	EM90 D32 W32 L150 Z03 LNGX 1205		1.700

TNGX 1004 PRMT



KOD	Stok Stock	Inter Cooland	Kesici Uç Uyumluluğu / Insert Suitability		FİYAT PRICE
			PRMT TNGX 1004		TL
ST TNGX 10 001 PRMT	✓	✓	EM90 D18 W16 L150 Z02 TNGX 1004		1.787
ST TNGX 10 002 PRMT	✓	✓	EM90 D21 W20 L150 Z03 TNGX 1004		1.917
ST TNGX 10 003 PRMT	✓	✓	EM90 D26 W25 L150 Z04 TNGX 1004		2.044
ST TNGX 10 004 PRMT	✓	✓	EM90 D26 W25 L200 Z04 TNGX 1004		2.213
ST TNGX 10 005 PRMT	✓	✓	EM90 D33 W32 L150 Z05 TNGX 1004		2.127
ST TNGX 10 006 PRMT	✓	✓	EM90 D33 W32 L200 Z05 TNGX 1004		2.297

ADMX 11T3 PRMT



AXMT 0602 TT



4NKT 0402 TT



4NKT 0603 TT



KOD	Stok Stock	Inter Cooland	Kesici Uç Uyumluluğu / Insert Suitability		FİYAT PRICE
			PRMT ADMX 11T3		TL
ST ADMX 11 001 PRMT	✓	X	EM90 D12 W12 L120 Z01 ADMX 11T3		1.194
ST ADMX 11 002 PRMT	✓	X	EM90 D16 W16 L150 Z02 ADMX 11T3		1.363
ST ADMX 11 002 PRMT (S)	✓	✓	EM90 D16 W16 L150 Z02 ADMX 11T3 inter cooland		1.492
ST ADMX 11 003 PRMT	✓	X	EM90 D20 W20 L150 Z03 ADMX 11T3		1.532
ST ADMX 11 003 PRMT (S)	✓	✓	EM90 D20 W20 L150 Z03 ADMX 11T3 inter cooland		1.660
ST ADMX 11 004 PRMT	✓	X	EM90 D25 W25 L200 Z03 ADMX 11T3		1.787
ST ADMX 11 005 PRMT	✓	X	EM90 D32 W32 L200 Z04 ADMX 11T3		2.085
ST ADMX 11 006 PRMT (S)	✓	✓	EM90 D25 W25 L200 Z04 ADMX 11T3 inter cooland		1.872

KOD	Stok Stock	Inter Cooland	Kesici Uç Uyumluluğu / Insert Suitability		FİYAT PRICE
			TT AXMT 0602		TL
ST AXMT 06 001 TT	✓	X	EM90 D10 W9 L120 Z02 AXMT 0602		1.275
ST AXMT 06 002 TT	✓	X	EM90 D11 W10 L100 Z02 AXMT 0602		1.322
ST AXMT 06 003 TT	✓	X	EM90 D12 W11 L120 Z02 AXMT 0602		1.403

KOD	Stok Stock	Inter Cooland	Kesici Uç Uyumluluğu / Insert Suitability		FİYAT PRICE
			TT 4NKT 0402		TL
ST 4NKT 04 001 TT	✓	X	EM90 D10 W10 L100 Z02 4NKT 0402		1.403
ST 4NKT 04 002 TT	✓	X	EM90 D12 W12 L120 Z03 4NKT 0402		1.618
ST 4NKT 04 003 TT	✓	X	EM90 D16 W16 L150 Z04 4NKT 0402		1.492

KOD	Stok Stock	Inter Cooland	Kesici Uç Uyumluluğu / Insert Suitability		FİYAT PRICE
			TT 4NKT 0603		TL
ST 4NKT 06 001 TT	✓	X	EM90 D16 W16 L120 Z02 4NKT 0603		1.275
ST 4NKT 06 002 TT (S)	✓	✓	EM90 D16 W16 L150 Z02 4NKT 0603 inter cooland		1.618
ST 4NKT 06 003 TT	✓	X	EM90 D17 W16 L150 Z02 4NKT 0603		1.532
ST 4NKT 06 003 TT (S)	✓	✓	EM90 D17 W16 L150 Z02 4NKT 0603 inter cooland		1.619
ST 4NKT 06 004 TT (S)	✓	X	EM90 D17 W16 L200 Z02 4NKT 0603 inter cooland		1.660
ST 4NKT 06 005 TT (S)	✓	✓	EM90 D20 W20 L160 Z03 4NKT 0603 inter cooland		1.917
ST 4NKT 06 006 TT (S)	✓	✓	EM90 D21 W20 L200 Z03 4NKT 0603 inter cooland		1.934
ST 4NKT 06 007 TT (S)	✓	✓	EM90 D25 W25 L200 Z03 4NKT 0603 inter cooland		1.958
ST 4NKT 06 008 TT (S)	✓	✓	EM90 D26 W25 L200 Z03 4NKT 0603 inter cooland		2.002
ST 4NKT 06 010 TT (S)	✓	✓	EM90 D20 W20 L120 Z03 4NKT 0603 inter cooland		1.449
ST 4NKT 06 012 TT (S)	✓	✓	EM90 D25 W25 L150 Z03 4NKT 0603 inter cooland		1.872
ST 4NKT 06 013 TT (S)	✓	✓	EM90 D25 W25 L120 Z04 4NKT 0603 inter cooland		1.917
ST 4NKT 06 015 TT (S)	✓	✓	EM90 D18 W16 L150 Z02 4NKT 0603 inter cooland		1.618
ST 4NKT 06 016 TT (S)	✓	✓	EM90 D22 W20 L160 Z03 4NKT 0603 inter cooland		1.917
ST 4NKT 06 021 TT (S)	✓	✓	EM90 D21 W20 L160 Z03 4NKT 0603 inter cooland		1.917

6NGU 0604 TT



KOD	Stok Stock	Inter Cooland	Kesici Uç Uyumluluğu / Insert Suitability	FIYAT PRICE
			TT 6NGU 0604	TL
ST 6NGU 06 004 TT	✓	✓	EM90 D32 W32 L150 Z03 6NGU 0604	2.213
ST 6NGU 06 005 TT	✓	✓	EM90 D25 W25 L150 Z02 6NGU 0604	1.787

2PKT 0503 TT



KOD	Stok Stock	Inter Cooland	Kesici Uç Uyumluluğu / Insert Suitability	FIYAT PRICE
			TT 2PKT 0503	TL
ST 2PKT 05 001 TT	✓	✗	EM90 D12 W11 L120 Z02 2PKT 0503	1.492
ST 2PKT 05 002 TT	✓	✗	EM90 D12 W12 L120 Z02 2PKT 0503	1.492

3PKT 1004 TT



KOD	Stok Stock	Inter Cooland	Kesici Uç Uyumluluğu / Insert Suitability	FIYAT PRICE
			TT 3PKT 1004	TL
ST 3PKT 1004 001 TT	✓	✓	EM90 D20 W20 L150 Z02 3PKT 1004	1.829
ST 3PKT 1004 002 TT	✓	✓	EM90 D25 W25 L150 Z03 3PKT 1004	1.958
ST 3PKT 1004 003 TT	✓	✓	EM90 D32 W32 L150 Z04 3PKT 1004	2.127

3PKT 1505 TT



KOD	Stok Stock	Inter Cooland	Kesici Uç Uyumluluğu / Insert Suitability	FIYAT PRICE
			TT 3PKT 1505	TL
ST 3PKT 15 001 TT	✓	✓	EM90 D32 W25 L150 Z03 3PKT 1505 TT	2.055
ST 3PKT 15 003 TT	✓	✓	EM90 D32 W32 L200 Z03 3PKT 1505 TT	2.224

Lütfen Sipariş vermeden önce stok durumunu sorunuz.
Please ask before ordering, stock status.

L: Sol / Left

R: Sağ / Right

✓ Stokta / In Stock

✗ Stokta Yok / Non Stock

APKT 09T3 TT



BDMT 1103 WDA



XDPT 1104 WDA



XNGU 1002 WDA



KOD	Stok Stock	Inter Cooland	Kesici Uç Uyumluluğu / Insert Suitability		FIYAT PRICE
			TT APKT 09T3		TL
ST APKT 09 001 TT	✓	X	EM90 D16 W15 L150 Z02 APKT 09T3		1.363
ST APKT 09 002 TT	✓	X	EM90 D17 W16 L200 Z02 APKT 09T3		1.618
ST APKT 09 003 TT	✓	X	EM90 D21 W20 L200 Z03 APKT 09T3		1.660

KOD	Stok Stock	Inter Cooland	Kesici Uç Uyumluluğu / Insert Suitability		FIYAT PRICE
			WDA BDMT 1103		TL
ST BDMT 11 002 WDA	X	X	EM90 D16 W16 L150 Z02 BDMT 1103		1.233
ST BDMT 11 004 WDA	X	X	EM90 D20 W20 L150 Z03 BDMT 1103		1.449
ST BDMT 11 005 WDA	X	X	EM90 D25 W25 L120 Z03 BDMT 1103		1.575

KOD	Stok Stock	Inter Cooland	Kesici Uç Uyumluluğu / Insert Suitability		FIYAT PRICE
			WDA XDPT 1104		TL
ST XDPT 11 001 WDA	✓	✓	EM90 D18 W16 L170 Z02 XDPT 1104		1.363
ST XDPT 11 002 WDA	✓	✓	EM90 D20 W20 L170 Z03 XDPT 1104		1.492
ST XDPT 11 003 WDA	✓	✓	EM90 D25 W25 L170 Z03 XDPT 1104		1.660
ST XDPT 11 004 WDA	✓	✓	EM90 D22 W20 L170 Z03 XDPT 1104		1.575
ST XDPT 11 005 WDA	✓	✓	EM90 D40 W32 L170 Z05 XDPT 1104		2.170
ST XDPT 11 007 WDA	✓	✓	EM90 D45 W25 L120 Z04 XDPT 1104		1.787

KOD	Stok Stock	Inter Cooland	Kesici Uç Uyumluluğu / Insert Suitability		FIYAT PRICE
			WDA XNGU 1002		TL
ST XNGU 10 001 WDA	✓	✓	EM90 D16 W16 L150 Z02 XNGU 1002		1.275
ST XNGU 10 002 WDA	✓	✓	EM90 D20 W20 L150 Z02 XNGU 1002		1.363
ST XNGU 10 003 WDA	✓	✓	EM90 D25 W25 L150 Z03 XNGU 1002		1.492

BOMT 09T308 INGRSL



KOD	Stok Stock	Inter Cooland	Kesici Uç Uyumluluğu / Insert Suitability	FIYAT PRICE
			INGRSL BOMT 09T308	TL
ST BOMT 09 001 INGRSL	✓	✗	EM90 D16 W16 L150 Z02 BOMT 09T308	1.363
ST BOMT 09 002 INGRSL	✓	✗	EM90 D18 W16 L150 Z02 BOMT 09T308	1.403
ST BOMT 09 003 INGRSL	✓	✗	EM90 D20 W20 L150 Z03 BOMT 09T308	1.532
ST BOMT 09 004 INGRSL	✓	✗	EM90 D22 W20 L150 Z03 BOMT 09T308	1.618

BOMT 1304 INGRSL



KOD	Stok Stock	Inter Cooland	Kesici Uç Uyumluluğu / Insert Suitability	FIYAT PRICE
			INGRSL BOMT 1304	TL
ST BOMT 13 001 INGRSL	✓	✗	EM90 D20 W20 L150 Z02 BOMT 1304	1.363
ST BOMT 13 002 INGRSL	✓	✗	EM90 D22 W20 L150 Z02 BOMT 1304	1.403
ST BOMT 13 003 INGRSL	✓	✗	EM90 D25 W25 L150 Z03 BOMT 1304	1.532
ST BOMT 13 004 INGRSL	✓	✗	EM90 D32 W25 L150 Z04 BOMT 1304	1.618
ST BOMT 13 005 INGRSL	✓	✗	EM90 D32 W32 L150 Z04 BOMT 1304	1.618

AOMT 1605 INGRSL



KOD	Stok Stock	Inter Cooland	Kesici Uç Uyumluluğu / Insert Suitability	FIYAT PRICE
			INGRSL AOMT 1605	TL
ST AOMT 16 001 INGRSL	✓	✗	EM90 D25 W25 L120 Z02 AOMT 1605	1.532
ST AOMT 16 002 INGRSL	✓	✗	EM90 D25 W25 L150 Z02 AOMT 1605	1.575
ST AOMT 16 003 INGRSL	✓	✗	EM90 D25 W25 L200 Z02 AOMT 1605	1.748
ST AOMT 16 004 INGRSL	✓	✗	EM90 D32 W25 L150 Z03 AOMT 1605	1.787
ST AOMT 16 005 INGRSL	✓	✗	EM90 D32 W32 L150 Z03 AOMT 1605	1.787

TOMT 0603/1004 TNGLY



KOD	Stok Stock	Inter Cooland	Kesici Uç Uyumluluğu / Insert Suitability		FIYAT PRICE
			TNGLY TOMT 0603/1004		TL
ST TOMT 06 001 TNG	✓	✓	EM90 D16 W16 L150 Z02 TOMT 0603		1.748
ST TOMT 06 003 TNG	✓	✓	EM90 D20 W20 L150 Z03 TOMT 0603		1.872

BDMT 0703 KYCR



KOD	Stok Stock	Inter Cooland	Kesici Uç Uyumluluğu / Insert Suitability		FIYAT PRICE
			KYCR BDMT-0703		TL
ST BDMT 07 001 KYCR	✓	X	EM90 D10 W10 L100 Z01 BDMT 0703		1.519
ST BDMT 07 002 KYCR	✓	X	EM90 D11 W10 L120 Z02 BDMT 0703		1.519
ST BDMT 07 003 KYCR	✓	X	EM90 D12 W11 L120 Z02 BDMT 0703		1.519
ST BDMT 07 004 KYCR	✓	X	EM90 D12 W12 L120 Z02 BDMT 0703		1.519
ST BDMT 07 005 KYCR	✓	X	EM90 D16 W16 L120 Z03 BDMT 0703		1.588
ST BDMT 07 006 KYCR	✓	X	EM90 D14 W12 L120 Z03 BDMT 0703		1.537

BDMT 1704 KYCR



KOD	Stok Stock	Inter Cooland	Kesici Uç Uyumluluğu / Insert Suitability		FIYAT PRICE
			KYCR BDMT 1704		TL
ST BDMT 17 001 KYCR	✓	✓	EM90 D25 W25 L160 Z02 BDMT 1704		1.609
ST BDMT 17 003 KYCR	✓	✓	EM90 D32 W32 L200 Z03 BDMT 1704		1.948

APKT 1003 KYCR



KOD	Stok Stock	Inter Cooland	Kesici Uç Uyumluluğu / Insert Suitability	FİYAT PRICE
			KYCR APKT 1003	TL
ST APKT 10 001 KYCR	✓	✓	EM90 D17 W16 L160 Z02 APKT 1003	1.458
ST APKT 10 002 KYCR	✓	✓	EM90 D21 W20 L160 Z03 APKT 1003	1.550
ST APKT 10 003 KYCR	✓	✓	EM90 D25 W25 L160 Z03 APKT 1003	1.638

BDMT 11T3 KYCR



KOD	Stok Stock	Inter Cooland	Kesici Uç Uyumluluğu / Insert Suitability	FİYAT PRICE
			KYCR BDMT-11T3	TL
ST BDMT 11 001 KYCR	✓	✓	EM90 D16 W16 L160 Z02 BDMT 11T3	1.417
ST BDMT 11 002 KYCR	✓	✓	EM90 D16 W16 L180 Z02 BDMT 11T3	1.458
ST BDMT 11 004 KYCR	✓	✓	EM90 D17 W16 L160 Z02 BDMT 11T3	1.417
ST BDMT 11 005 KYCR	✓	✓	EM90 D17 W16 L200 Z02 BDMT 11T3	1.550
ST BDMT 11 006 KYCR	✓	✗	EM90 D17 W16 L260 Z02 BDMT 11T3	1.726
ST BDMT 11 007 KYCR	✓	✓	EM90 D20 W20 L110 Z03 BDMT 11T3	1.407
ST BDMT 11 008 KYCR	✓	✓	EM90 D20 W20 L160 Z03 BDMT 11T3	1.550
ST BDMT 11 009 KYCR	✓	✓	EM90 D20 W20 L180 Z03 BDMT 11T3	1.592
ST BDMT 11 010 KYCR	✓	✓	EM90 D20 W20 L200 Z03 BDMT 11T3	1.682
ST BDMT 11 011 KYCR	✓	✓	EM90 D21 W20 L160 Z03 BDMT 11T3	1.550
ST BDMT 11 012 KYCR	✓	✓	EM90 D21 W20 L180 Z03 BDMT 11T3	1.592
ST BDMT 11 013 KYCR	✓	✓	EM90 D21 W20 L200 Z03 BDMT 11T3	1.682
ST BDMT 11 014 KYCR	✓	✗	EM90 D21 W20 L260 Z03 BDMT 11T3	1.946
ST BDMT 11 015 KYCR	✓	✓	EM90 D25 W25 L160 Z03 BDMT 11T3	1.726
ST BDMT 11 016 KYCR	✓	✓	EM90 D25 W25 L200 Z03 BDMT 11T3	1.760
ST BDMT 11 017 KYCR	✓	✓	EM90 D26 W25 L160 Z03 BDMT 11T3	1.726
ST BDMT 11 018 KYCR	✓	✓	EM90 D26 W25 L200 Z03 BDMT 11T3	1.901
ST BDMT 11 019 KYCR	✓	✗	EM90 D26 W25 L260 Z03 BDMT 11T3	1.901
ST BDMT 11 021 KYCR	✓	✓	EM90 D32 W32 L200 Z04 BDMT 11T3	2.301
ST BDMT 11 024 KYCR	✓	✓	EM90 D33 W32 L200 Z04 BDMT 11T3	2.301
ST BDMT 11 026 KYCR	✓	✓	EM90 D16 W15 L160 Z02 BDMT 11T3	1.417
ST BDMT 11 027 KYCR	✓	✓	EM90 D18 W16 L160 Z02 BDMT 11T3	1.550
ST BDMT 11 030 KYCR	✓	✓	EM90 D20 W20 L120 Z03 BDMT 11T3	1.458
ST BDMT 11 031 KYCR	✓	✓	EM90 D33 W32 L150 Z04 BDMT 11T3	2.035

LOMU 1505 KYCR



KOD	Stok Stock	Inter Cooland	Kesici Uç Uyumluluğu / Insert Suitability	FİYAT PRICE
			KYCR LOMU-1505	TL
ST LOMU 15 008 KYCR	✓	✓	EM90 D28 W25 L160 Z02 LOMU 1505	1.977
ST LOMU 15 009 KYCR	✓	✓	EM90 D32 W25 L160 Z03 LOMU 1505	2.337
ST LOMU 15 010 KYCR	✓	✓	EM90 D32 W32 L160 Z03 LOMU 1505	2.652

WNUMU 0504 KYCR



KOD	Stok Stock	Inter Cooland	Kesici Uç Uyumluluğu / Insert Suitability	FİYAT PRICE
			KYCR WNUMU 0504	TL
ST WNUMU 05 001 KYCR	✓	✓	EM90 D22 W20 L160 Z02 WNUMU 0504	1.506
ST WNUMU 05 002 KYCR	✓	✓	EM90 D25 W25 L120 Z02 WNUMU 0504	1.506
ST WNUMU 05 003 KYCR	✓	✓	EM90 D25 W25 L160 Z02 WNUMU 0504	1.638
ST WNUMU 05 004 KYCR	✓	✓	EM90 D26 W25 L160 Z02 WNUMU 0504	1.638
ST WNUMU 05 006 KYCR	✓	✓	EM90 D32 W32 L160 Z03 WNUMU 0504	1.768
ST WNUMU 05 007 KYCR	✓	✓	EM90 D32 W32 L200 Z03 WNUMU 0504	1.946
ST WNUMU 05 010 KYCR	✓	✓	EM90 D30 W25 L120 Z03 WNUMU 0504	1.682
ST WNUMU 08 002 KYCR	✓	✓	EM90 D40 W20 L100 Z03 WNUMU 0806	1.417
ST WNUMU 08 003 KYCR	✗	✓	EM90 D40 W32 L160 Z03 WNUMU 0806	1.638
ST WNUMU 08 004 KYCR	✓	✓	EM90 D40 W32 L150 Z03 WNUMU 0806	1.638

LOMU 1004 KYCR



KOD	Stok Stock	Inter Cooland	Kesici Uç Uyumluluğu / Insert Suitability	FİYAT PRICE
			KYCR LOMU-1004	TL
ST LOMU 10 001 KYCR	✓	✓	EM90 D16 W16 L100 Z02 LOMU 1004	1.537
ST LOMU 10 002 KYCR	✓	✓	EM90 D16 W16 L160 Z02 LOMU 1004	1.729
ST LOMU 10 003 KYCR	✓	✓	EM90 D17 W16 L160 Z02 LOMU 1004	1.729
ST LOMU 10 005 KYCR	✓	✓	EM90 D20 W20 L150 Z02 LOMU 1004	1.866
ST LOMU 10 007 KYCR	✓	✓	EM90 D21 W20 L160 Z03 LOMU 1004	1.917
ST LOMU 10 010 KYCR	✓	✓	EM90 D16 W16 L150 Z02 LOMU 1004	1.679
ST LOMU 10 012 KYCR	✓	✓	EM90 D20 W20 L110 Z03 LOMU 1004	1.822
ST LOMU 10 013 KYCR	✓	✓	EM90 D20 W20 L160 Z03 LOMU 1004	1.866
ST LOMU 10 014 KYCR	✓	✓	EM90 D26 W25 L160 Z03 LOMU 1004	2.241
ST LOMU 10 015 KYCR	✓	✓	EM90 D25 W25 L160 Z03 LOMU 1004	2.241
ST LOMU 10 016 KYCR	✓	✓	EM90 D25 W25 L200 Z03 LOMU 1004	2.289
ST LOMU 10 017 KYCR	✓	✓	EM90 D28 W25 L160 Z04 LOMU 1004	2.289
ST LOMU 10 019 KYCR	✓	✓	EM90 D21 W20 L200 Z03 LOMU 1004	2.069

SOMT 1004 KYCR



KOD	Stok Stock	Inter Cooland	Kesici Uç Uyumluluğu / Insert Suitability	FİYAT PRICE
			KYCR SOMT 1004	TL
ST SOMT 10 001 KYCR	✓	✓	BMR D25 W25 L160 Z02 SOMT 1004	1.782
ST SOMT 10 002 KYCR	✓	✓	BMR D26 W25 L160 Z02 SOMT 1004	1.926
ST SOMT 10 003 KYCR	✓	✓	BMR D33 W32 L160 Z03 SOMT 1004	2.091

XDKT 11T3 CRTZT



KOD	Stok Stock	Inter Cooland	Kesici Uç Uyumluluğu / Insert Suitability		FİYAT PRICE
			CRTZ XDKT 11T3		TL
ST XDKT 11T 001 CRTZ	✓	✗	EM90 D16 W15 L150 Z02 XDKT 11T3		1.363
ST XDKT 11T 002 CRTZ	✓	✗	EM90 D20 W19 L150 Z03 XDKT 11T3		1.403
ST XDKT 11T 003 CRTZ	✓	✗	EM90 D25 W24 L150 Z03 XDKT 11T3		1.492
ST XDKT 11T 004 CRTZ	✓	✗	EM90 D32 W25 L150 Z04 XDKT 11T3		1.660

APKT 1604 BHLR



KOD	Stok Stock	Inter Cooland	Kesici Uç Uyumluluğu / Insert Suitability		FİYAT PRICE
			BHLR APKT 1604		TL
ST APKT 16 001 BHLR	✓	✗	EM90 D25 W25 L150 Z02 APKT 1604		1.532
ST APKT 16 002 BHLR	✓	✗	EM90 D32 W32 L150 Z03 APKT 1604		1.618

SDMT 06/09 ZCC



KOD	Stok Stock	Inter Cooland	Kesici Uç Uyumluluğu / Insert Suitability		FİYAT PRICE
			ZCC SDMT 06/09		TL
ST SDMT 06 002 ZCC	✓	✓	BMR D16 W16 L150 Z02 SDMT 06T2		1.458
ST SDMT 06 003 ZCC	✓	✓	BMR D17 W16 L160 Z02 SDMT 06T2		1.458
ST SDMT 06 004 ZCC	✓	✓	BMR D20 W20 L160 Z03 SDMT 06T2		1.550
ST SDMT 06 005 ZCC	✓	✓	BMR D20 W20 L150 Z02 SDMT 06T2		1.506
ST SDMT 06 006 ZCC	✓	✓	BMR D20 W20 L150 Z03 SDMT 06T2		1.550
ST SDMT 06 007 ZCC	✓	✓	BMR D21 W20 L200 Z03 SDMT 06T2		1.726
ST SDMT 09 002 ZCC	✓	✓	BMR D22 W20 L170 Z02 SDMT 09T3		1.550
ST SDMT 09 005 ZCC	✓	✓	BMR D25 W25 L160 Z02 SDMT 09T3		1.550
ST SDMT 09 006 ZCC	✓	✓	BMR D26 W25 L200 Z02 SDMT 09T3		1.726
ST SDMT 09 007 ZCC	✓	✓	BMR D32 W25 L150 Z03 SDMT 09T3		1.857
ST SDMT 09 008 ZCC	✓	✓	BMR D32 W32 L150 Z03 SDMT 09T3		1.857
ST SDMT 09 009 ZCC	✓	✓	BMR D32 W32 L160 Z03 SDMT 09T3		1.857
ST SDMT 09 011 ZCC	✓	✓	BMR D33 W32 L200 Z04 SDMT 09T3		1.946
ST SDMT 09 012 ZCC	✓	✓	BMR D42 W32 L160 Z04 SDMT 09T3		2.211
ST SDMT 09 013 ZCC	✓	✓	BMR D33 W32 L160 Z03 SDMT 09T3		1.857
ST SDMT 09 014 ZCC	✓	✓	BMR D32 W32 L200 Z03 SDMT 09T3		1.946
ST SDMT 09 015 ZCC	✓	✓	BMR D25 W25 L200 Z02 SDMT 09T3		1.726
ST SDMT 09 016 ZCC	✓	✓	BMR D25 W25 L160 Z03 SDMT 09T3		1.682
ST SDMT 09 019 ZCC	✓	✓	BMR D26 W25 L160 Z02 SDMT 09T3		1.550
ST SDMT 09 020 ZCC	✓	✓	BMR D26 W25 L160 Z03 SDMT 09T3		1.571
ST SDMT 09 021 ZCC	✓	✓	BMR D26 W25 L200 Z03 SDMT 09T3		1.859
ST SDMT 09 022 ZCC	✓	✓	BMR D33 W32 L250 Z03 SDMT 09T3		2.103
ST SDMT 09 023 ZCC	✓	✓	BMR D35 W32 L160 Z04 SDMT 09T3		1.946
ST SDMT 09 024 ZCC	✓	✓	BMR D25 W25 L200 Z03 SDMT 09T3		1.726

WPGT 0503 ZCC



KOD	Stok Stock	Inter Cooland	Kesici Uç Uyumluluğu / Insert Suitability	FIYAT PRICE
			WPGT 0503 ZCC	TL
ST WPGT 05 001 ZCC	✓	✓	BMR D21 W20 L170 Z02 WPGT 0503	1.768
ST WPGT 05 002 ZCC	✓	✓	BMR D26 W25 L200 Z03 WPGT 0503	1.946

SP..08T3 PLBT



KOD	Stok Stock	Inter Cooland	Kesici Uç Uyumluluğu / Insert Suitability	FIYAT PRICE
			PLBT SP..08T3/09T3	TL
ST SPKT 08 001 PLBT	X	X	BMR D20 W20 L150 Z02 SPKT 08T3	1.532
ST SPKT 08 002 PLBT	X	X	BMR D25 W25 L150 Z03 SPKT 08T3	1.532

SDMX 09T308 PLBT



KOD	Stok Stock	Inter Cooland	Kesici Uç Uyumluluğu / Insert Suitability	FIYAT PRICE
			PLBT SDMX 09T308	TL
ST SDMX 09 002 PLBT	✓	✓	BMR D25 W25 L150 Z03 SDMX 09T3	1.575
ST SDMX 09 003 PLBT	✓	✓	BMR D32 W32 L150 Z04 SDMX 09T3	1.787

BLMP 0603 TT



KOD	Stok Stock	Inter Cooland	Kesici Uç Uyumluluğu / Insert Suitability		FİYAT PRICE
			TT BLM. 0603		TL
ST BLMP 06 001 TT	✓	✓	BMR D16 W15 L150 Z02	BLMP 0603	1.492
ST BLMP 06 002 TT	✓	✓	BMR D16 W16 L150 Z02	BLMP 0603	1.492
ST BLMP 06 003 TT	✓	✓	BMR D17 W16 L150 Z02	BLMP 0603	1.532
ST BLMP 06 004 TT	✓	✓	BMR D17 W16 L200 Z02	BLMP 0603	1.700
ST BLMP 06 005 TT	✓	✓	BMR D21 W20 L150 Z03	BLMP 0603	1.575
ST BLMP 06 006 TT	✓	✓	BMR D21 W20 L200 Z03	BLMP 0603	1.748
ST BLMP 06 007 TT	✓	✓	BMR D26 W25 L150 Z04	BLMP 0603	1.958
ST BLMP 06 008 TT	✓	✓	BMR D26 W25 L200 Z04	BLMP 0603	2.213
ST BLMP 06 009 TT	✓	✓	BMR D25 W25 L150 Z04	BLMP 0603	1.917
ST BLMP 06 010 TT	✓	✓	BMR D20 W20 L150 Z03	BLMP 0603	1.575
ST BLMP 06 011 TT	✓	✓	BMR D32 W32 L200 Z05	BLMP 0603	2.297
ST BLMP 06 012 TT	✓	✓	BMR D33 W32 L200 Z05	BLMP 0603	2.297
ST BLMP 06 013 TT	✓	✓	BMR D17 W16 L100 Z02	BLMP 0603	1.403

LPGT 0102 KYCR



KOD	Stok Stock	Inter Cooland	Kesici Uç Uyumluluğu / Insert Suitability		FİYAT PRICE
			KYCR LPGT 0102		TL
ST LPGT 01 001 KYCR	✓	✗	BMR D9 W10 L75 Z02	LPGT 010210	1.541
ST LPGT 01 002 KYCR	✓	✗	BMR D10 W10 L100 Z02	LPGT 0102	1.587
ST LPGT 01 003 KYCR	✓	✗	BMR D11 W10 L120 Z02	LPGT 0102	1.688
ST LPGT 01 004 KYCR	✓	✗	BMR D12 W11 L120 Z02	LPGT 0102	1.734
ST LPGT 01 005 KYCR	✓	✗	BMR D12 W11 L120 Z03	LPGT 0102	1.783
ST LPGT 01 006 KYCR	✓	✗	BMR D12 W12 L120 Z02	LPGT 0102	1.734
ST LPGT 01 007 KYCR	✓	✗	BMR D12 W12 L150 Z03	LPGT 0102	1.879
ST LPGT 01 010 KYCR	✓	✗	BMR D16 W16 L160 Z04	LPGT 0102	2.119
ST LPGT 01 011 KYCR	✓	✗	BMR D12 W12 L100 Z02	LPGT 0102	1.639
ST LPGT 01 012 KYCR	✓	✗	BMR D12 W12 L120 Z03	LPGT 0102	1.783
ST LPGT 01 013 KYCR	✓	✗	BMR D14 W14 L120 Z03	LPGT 0102	1.831
ST LPGT 01 014 KYCR	✓	✗	BMR D10 W09 L120 Z02	LPGT 0102	1.639

LOGU 0303 KYCR



KOD	Stok Stock	Inter Cooland	Kesici Uç Uyumluluğu / Insert Suitability		FİYAT PRICE
			KYCR LOGU 0303		TL
ST LOGU 03 002 KYCR	✓	✓	BMR D16 W16 L160 Z02	LOGU 0303	1.528
ST LOGU 03 003 KYCR	✓	✓	BMR D16 W16 L200 Z02	LOGU 0303	1.652
ST LOGU 03 004 KYCR	✓	✓	BMR D17 W16 L160 Z02	LOGU 0303	1.528
ST LOGU 03 005 KYCR	✓	✓	BMR D17 W16 L200 Z02	LOGU 0303	1.652
ST LOGU 03 006 KYCR	✓	✓	BMR D18 W16 L160 Z02	LOGU 0303	1.571
ST LOGU 03 007 KYCR	✓	✓	BMR D20 W20 L130 Z03	LOGU 0303	1.528
ST LOGU 03 008 KYCR	✓	✓	BMR D20 W20 L160 Z03	LOGU 0303	1.652
ST LOGU 03 010 KYCR	✓	✓	BMR D21 W20 L160 Z03	LOGU 0303	1.652
ST LOGU 03 012 KYCR	✓	✓	BMR D22 W20 L160 Z03	LOGU 0303	1.652
ST LOGU 03 013 KYCR	✓	✓	BMR D25 W25 L160 Z04	LOGU 0303	1.985
ST LOGU 03 014 KYCR	✓	✓	BMR D25 W25 L180 Z04	LOGU 0303	2.064
ST LOGU 03 016 KYCR	✓	✓	BMR D26 W25 L160 Z04	LOGU 0303	2.024
ST LOGU 03 020 KYCR	✓	✓	BMR D32 W32 L160 Z05	LOGU 0303	2.104
ST LOGU 03 021 KYCR	✓	✓	BMR D32 W32 L200 Z05	LOGU 0303	2.314
ST LOGU 03 022 KYCR	✓	✓	BMR D33 W32 L160 Z05	LOGU 0303	2.104
ST LOGU 03 024 KYCR	✓	✓	BMR D28 W25 L160 Z04	LOGU 0303	2.064
ST LOGU 03 025 KYCR	✓	✓	BMR D16 W15 L160 Z02	LOGU 0303	1.528
ST LOGU 03 026 KYCR	✓	✓	BMR D20 W20 L200 Z03	LOGU 0303	1.761
ST LOGU 03 027 KYCR	✓	✓	BMR D20 W20 L110 Z03	LOGU 0303	1.528
ST LOGU 03 029 KYCR	✓	✓	BMR D26 W25 L200 Z04	LOGU 0303	2.187
ST LOGU 03 030 KYCR	✓	✗	BMR D26 W25 L250 Z04	LOGU 0303	2.355
ST LOGU 03 031 KYCR	✓	✓	BMR D16 W16 L110 Z02	LOGU 0303	1.404
ST LOGU 03 032 KYCR	✓	✓	BMR D21 W20 L200 Z03	LOGU 0303	1.848
ST LOGU 03 033 KYCR	✓	✓	BMR D28 W25 L200 Z04	LOGU 0303	2.187

SOMT 12T3 MTSBHS



KOD	Stok Stock	Inter Cooland	Kesici Uç Uyumluluğu / Insert Suitability	FİYAT PRICE
			MTSBHS SOMT 12T3	TL
ST SOMT 12 001 MTSBHS	✓	✓	BMR D32 W32 L150 Z02 SOMT 12T3	1.787
ST SOMT 12 002 MTSBHS	✓	✓	BMR D40 W32 L150 Z03 SOMT 12T3	2.002

P26335 R10/R14 WLTR



KOD	Stok Stock	Inter Cooland	Kesici Uç Uyumluluğu / Insert Suitability	FİYAT PRICE
			WLTR P26335 -R10-R14	TL
ST P2633 R 10 002 WLTR	✓	✓	BMR D25 W25 L150 Z03 P26335R-10	1.618
ST P2633 R 10 003 WLTR	✓	✓	BMR D26 W25 L200 Z03 P26335R-10	1.872
ST P2633 R 10 004 WLTR	✓	✓	BMR D32 W32 L150 Z04 P26335R-10	1.958
ST P2633 R 14 001 WLTR	✓	✓	BMR D32 W32 L150 Z03 P26335R-14	1.958

WNMX 09T3 KRLY



KOD	Stok Stock	Inter Cooland	Kesici Uç Uyumluluğu / Insert Suitability	FİYAT PRICE
			KRLY WNMX 09T3	TL
ST WNMX 09 003 KRLY	✓	✓	BMR D25 W25 L150 Z02 WNMX 09T3	1.532
ST WNMX 09 004 KRLY	✓	✓	BMR D32 W32 L150 Z03 WNMX 09T3	1.829

WNMX 0603 KRLY



KOD	Stok Stock	Inter Cooland	Kesici Uç Uyumluluğu / Insert Suitability		FIYAT PRICE
			KRLY WNMX 0603		TL
ST WNMX 06 001 KRLY	✓	✓	BMR D16 W16 L150 Z02 WNMX 0603		1.403
ST WNMX 06 002 KRLY	✓	✓	BMR D20 W20 L150 Z03 WNMX 0603		1.532
ST WNMX 06 003 KRLY	✓	✓	BMR D17 W16 L150 Z02 WNMX 0603		1.403
ST WNMX 06 004 KRLY	✓	✓	BMR D21 W20 L150 Z03 WNMX 0603		1.532

LPMW 0402 KRLY



KOD	Stok Stock	Inter Cooland	Kesici Uç Uyumluluğu / Insert Suitability		FIYAT PRICE
			KRLY LPMW 0402		TL
ST LPMW 0402 001 KRLY	✓	✗	BMR D10 W10 L120 Z02 LPMW 0402		1.748
ST LPMW 0402 002 KRLY	✓	✗	BMR D12 W12 L120 Z03 LPMW 0402		1.829
ST LPMW 0402 004 KRLY	✓	✗	BMR D16 W16 L150 Z04 LPMW 0402		2.044
ST LPMW 0402 003 KRLY	✓	✗	BMR D16 W16 L120 Z04 LPMW 0402		1.917
ST LPMW 0402 005 KRLY	✓	✗	BMR D14 W12 L120 Z03 LPMW 0402		1.872

LNMX 060310 KRLY



KOD	Stok Stock	Inter Cooland	Kesici Uç Uyumluluğu / Insert Suitability		FIYAT PRICE
			KRLY LNMX 0603		TL
ST LNMX 06 001 KRLY	✓	✓	BMR D16 W16 L130 Z02 LNMX 0603		1.492
ST LNMX 06 002 KRLY	✓	✓	BMR D20 W20 L150 Z03 LNMX 0603		1.660
ST LNMX 06 003 KRLY	✓	✓	BMR D25 W25 L160 Z04 LNMX 0603		1.829
ST LNMX 06 005 KRLY	✓	✓	BMR D17 W16 L200 Z02 LNMX 0603		1.700
ST LNMX 06 006 KRLY	✓	✓	BMR D16 W16 L150 Z02 LNMX 0603		1.492
ST LNMX 06 007 KRLY	✓	✓	BMR D20 W20 L250 Z03 LNMX 0603		1.872
ST LNMX 06 008 KRLY	✓	✓	BMR D21 W20 L150 Z03 LNMX 0603		1.660
ST LNMX 06 009 KRLY	✓	✓	BMR D25 W25 L150 Z04 LNMX 0603		1.829
ST LNMX 06 010 KRLY	✓	✓	BMR D25 W25 L250 Z04 LNMX 0603		2.044
ST LNMX 06 011 KRLY	✓	✓	BMR D32 W32 L150 Z05 LNMX 0603		2.127
ST LNMX 06 013 KRLY	✓	✓	BMR D40 W32 L150 Z06 LNMX 0603		2.297

SDMT 1004 BHLR



KOD	Stok Stock	Inter Cooland	Kesici Uç Uyumluluğu / Insert Suitability		FİYAT PRICE
			BHLR SDMT 1004		TL
ST SDMT 10 003 BHLR	✓	✓	BMR D32 W32 L150 Z03 SDMT 1004		1.872
ST SDMT 10 005 BHLR	✓	✓	BMR D33 W32 L200 Z03 SDMT 1004		2.085

ZDCW 09T3 PRMT



KOD	Stok Stock	Inter Cooland	Kesici Uç Uyumluluğu / Insert Suitability		FİYAT PRICE
			PRMT ZDCW 09T3		TL
ST ZDCW 09 002 PRMT	✓	✓	BMR D25 W25 L150 Z02 ZDCW 09T3		1.700
ST ZDCW 09 003 PRMT	✓	✓	BMR D32 W32 L150 Z03 ZDCW 09T3		1.958

LNMU 0303 TNGLY



KOD	Stok Stock	Inter Cooland	Kesici Uç Uyumluluğu / Insert Suitability		FİYAT PRICE
			TNGLY LNMU 0303		TL
ST LNMU 03 001 TNG	✓	✓	BMR D16 W16 L160 Z02 LNMU 0303		1.622
ST LNMU 03 002 TNG	✓	✓	BMR D18 W16 L150 Z02 LNMU 0303		1.660
ST LNMU 03 003 TNG	✓	✓	BMR D20 W20 L160 Z03 LNMU 0303		1.785
ST LNMU 03 004 TNG	✓	✓	BMR D21 W20 L160 Z03 LNMU 0303		1.785
ST LNMU 03 006 TNG	✓	✓	BMR D25 W25 L160 Z04 LNMU 0303		2.159
ST LNMU 03 007 TNG	✓	✓	BMR D32 W32 L160 Z04 LNMU 0303		2.324
ST LNMU 03 008 TNG	✓	✓	BMR D21 W20 L200 Z03 LNMU 0303		1.909
ST LNMU 03 009 TNG	✓	✓	BMR D25 W25 L200 Z04 LNMU 0303		2.285
ST LNMU 03 010 TNG	✓	✓	BMR D26 W25 L160 Z04 LNMU 0303		2.159
ST LNMU 03 011 TNG	✓	✓	BMR D32 W32 L200 Z04 LNMU 0303		2.450
ST LNMU 03 012 TNG	✓	✓	BMR D33 W32 L200 Z04 LNMU 0303		2.450
ST LNMU 03 013 TNG	✓	✓	BMR D26 W25 L250 Z04 LNMU 0303		2.408
ST LNMU 03 014 TNG	✓	✗	BMR D26 W25 L200 Z04 LNMU 0303		2.285
ST LNMU 03 015 TNG	✓	✓	BMR D20 W20 L200 Z03 LNMU 0303		1.993
ST LNMU 03 016 TNG	✓	✓	BMR D22 W20 L160 Z03 LNMU 0303		1.785
ST LNMU 03 017 TNG	✓	✓	BMR D17 W16 L160 Z02 LNMU 0303		1.622
ST LNMU 03 018 TNG	✓	✓	BMR D17 W16 L200 Z02 LNMU 0303		1.785
ST LNMU 03 019 TNG	✓	✓	BMR D33 W32 L160 Z05 LNMU 0303		2.337
ST LNMU 03 020 TNG	✓	✓	BMR D16 W16 L200 Z02 LNMU 0303		1.785
ST LNMU 03 021 TNG	✓	✓	BMR D16 W16 L250 Z02 LNMU 0303		1.915

XPPT 070308 WDA



KOD	Stok Stock	Inter Cooland	Kesici Uç Uyumluluğu / Insert Suitability	FİYAT PRICE
			WDA XPPT 0703	TL
ST XPPT 07 001 WDA	✓	✓	BMR D16 W16 L170 Z02 XPPT 0703	1.363
ST XPPT 07 002 WDA	✓	✓	BMR D20 W20 L170 Z02 XPPT 0703	1.449
ST XPPT 07 007 WDA	✓	✓	BMR D20 W20 L170 Z03 XPPT 0703	1.573

SOMW 0803 SNG



KOD	Stok Stock	Inter Cooland	Kesici Uç Uyumluluğu / Insert Suitability	FİYAT PRICE
			SNG SOMW 0803	TL
ST SOMW 08 002 SNG	✓	✓	BMR D20 W20 L160 Z02 SOMW 0803	1.458
ST SOMW 08 003 SNG	✓	✓	BMR D25 W25 L160 Z03 SOMW 0803	1.638
ST SOMW 08 004 SNG	✓	✓	BMR D32 W32 L160 Z04 SOMW 0803	2.081
ST SOMW 08 005 SNG	✓	✓	BMR D26 W25 L200 Z03 SOMW 0803	1.726
ST SOMW 08 006 SNG	✓	✓	BMR D20 W20 L200 Z02 SOMW 0803	1.576
ST SOMW 08 007 SNG	✓	✓	BMR D25 W25 L200 Z03 SOMW 0803	1.794
ST SOMW 08 008 SNG	✓	✓	BMR D32 W32 L200 Z04 SOMW 0803	2.256

YNGX 0603 SNG



KOD	Stok Stock	Inter Cooland	Kesici Uç Uyumluluğu / Insert Suitability	FİYAT PRICE
			SNG YNGX 0603	TL
ST YNGX 06 001 SNG	✗	✓	EM90 D16 W16 L160 Z02 YNGX 0603	1.592
ST YNGX 06 002 SNG	✗	✓	EM90 D17 W16 L160 Z02 YNGX 0603	1.592
ST YNGX 06 003 SNG	✗	✓	EM90 D20 W20 L160 Z03 YNGX 0603	1.817
ST YNGX 06 005 SNG	✗	✓	EM90 D25 W25 L160 Z03 YNGX 0603	1.946
ST YNGX 06 006 SNG	✗	✓	EM90 D26 W25 L160 Z03 YNGX 0603	1.946

SPMW 1204 SNG



KOD	Stok Stock	Inter Cooland	Kesici Uç Uyumluluğu / Insert Suitability	FIYAT PRICE
			SNG SPMW 1204	TL
ST SPMW 12 001 SNG	✓	✓	BMR D32 W32 L160 Z02 SPMW 1204	1.726

XPW. 0603 VNDRT



KOD	Stok Stock	Inter Cooland	Kesici Uç Uyumluluğu / Insert Suitability	FIYAT PRICE
			VNDRT XPW.0603TN	TL
ST XPW 06 002 VNDRT	✓	✓	BMR D17 W16 L150 Z02 XPW. 0603TN	1.449
ST XPW 06 004 VNDRT	✓	✓	BMR D21 W20 L150 Z03 XPW. 0603TN	1.618

XDHW 060210 PLB / VNDRT



KOD	Stok Stock	Inter Cooland	Kesici Uç Uyumluluğu / Insert Suitability	FIYAT PRICE
			PLB / VNDRT XDHW 060210	
ST XDHW 06 001 PLB/VND	✓	✓	BMR D16 W16 L150 Z02 XDHW 0602	1.575
ST XDHW 06 002 PLB/VND	✓	✓	BMR D17 W16 L150 Z02 XDHW 0602	1.575
ST XDHW 06 003 PLB/VND	✓	✓	BMR D20 W20 L150 Z03 XDHW 0602	1.618
ST XDHW 06 004 PLB/VND	✓	✓	BMR D25 W25 L150 Z04 XDHW 0602	1.700

ENMX 08T3 WLTR



KOD	Stok Stock	Inter Cooland	Kesici Uç Uyumluluğu / Insert Suitability	FIYAT PRICE
			WLTR ENMX 08T3	TL
ST ENMX 08 001 WLTR	✓	✓	BMR D16 W16 L150 Z02 ENMX 08T3	1.618
ST ENMX 08 003 WLTR	✓	✓	BMR D16 W16 L200 Z02 ENMX 08T3	1.787
ST ENMX 08 004 WLTR	✓	✓	BMR D20 W20 L150 Z03 ENMX 08T3	1.787
ST ENMX 08 006 WLTR	✓	✓	BMR D25 W25 L150 Z04 ENMX 08T3	2.127

WDKT 08 ISO



KOD	Stok Stock	Inter Cooland	Kesici Uç Uyumluluğu / Insert Suitability		FİYAT PRICE
			ISO WDKT 08		TL
ST WDKT 08 002 ISO	✓	✗	BMR D25 W25 L150 Z02 WDKT 08		1.403
ST WDKT 08 003 ISO	✓	✗	BMR D30 W32 L150 Z02 WDKT 08		1.618
ST WDKT 08 004 ISO	✓	✗	BMR D32 W32 L150 Z03 WDKT 08		1.660

RD..05/07/08/10/12 ISO



KOD	Stok Stock	Inter Cooland	Kesici Uç Uyumluluğu / Insert Suitability		FİYAT PRICE
			ISO RD.. 05/07/08/10/12		TL
ST RD..05 001 ISO	✓	✗	EMR D10 W10 L100 Z02 RD..0501		937
ST RD..05 003 ISO	✓	✗	EMR D12 W12 L100 Z02 RD..0501		937
ST RD..08 007 ISO	✓	✓	EMR D16 W16 L120 Z02 RD..0803		937
ST RD..08 008 ISO	✓	✓	EMR D16 W16 L150 Z02 RD..0803		1.233
ST RD..08 011 ISO	✓	✓	EMR D20 W20 L150 Z03 RD..0802		1.322
ST RD..10 009 ISO	✓	✓	EMR D32 W32 L200 Z03 RD..1003		1.872
ST RD..10 012 ISO	✓	✓	EMR D20 W20 L120 Z02 RD..1003		1.064
ST RD..10 013 ISO	✓	✓	EMR D20 W20 L150 Z02 RD..1003		1.233
ST RD..10 014 ISO	✓	✓	EMR D20 W20 L200 Z02 RD..1003		1.492
ST RD..10 015 ISO	✓	✓	EMR D25 W25 L150 Z02 RD..1003		1.363
ST RD..10 016 ISO	✓	✓	EMR D25 W25 L200 Z02 RD..1003		1.532
ST RD..10 017 ISO	✓	✓	EMR D32 W32 L150 Z03 RD..1003		1.492
ST RD..10 019 ISO	✓	✗	EMR D32 W32 L250 Z03 RD..1003		1.748
ST RD..10 020 ISO	✓	✓	EMR D40 W32 L150 Z04 RD..1003		1.787
ST RD..10 021 ISO	✓	✗	EMR D40 W32 L250 Z02 RD..1003		1.872
ST RD..10 022 ISO	✓	✗	EMR D40 W32 L250 Z04 RD..1003		1.958
ST RD..10 023 ISO	✓	✓	EMR D20 W20 L150 Z02 RD..10T3		1.233
ST RD..10 024 ISO	✓	✓	EMR D25 W25 L150 Z02 RD..10T3		1.403
ST RD..10 025 ISO	✓	✓	EMR D25 W25 L200 Z02 RD..10T3		1.575
ST RD..10 029 ISO	✓	✓	EMR D40 W32 L150 Z04 RD..10T3		1.872
ST RD..10 030 ISO	✓	✓	EMR D40 W32 L250 Z02 RD..10T3		2.085
ST RD..10 031 ISO	✓	✗	EMR D40 W32 L250 Z04 RD..10T3		2.213
ST RD..10 032 ISO	✓	✗	EMR D32 W32 L160 Z03 RD..10T3		1.492
ST RD..12 032 ISO	✓	✓	EMR D25 W25 L150 Z02 RD..1204		1.449
ST RD..12 033 ISO	✓	✓	EMR D32 W25 L150 Z03 RD..1204		1.492
ST RD..12 034 ISO	✓	✓	EMR D32 W32 L150 Z03 RD..1204		1.492
ST RD..12 035 ISO	✓	✓	EMR D40 W25 L150 Z04 RD..1204		1.787
ST RD..12 036 ISO	✓	✓	EMR D40 W32 L150 Z04 RD..1204		1.787
ST RD..12 037 ISO	✓	✓	EMR D32 W25 L200 Z03 RD..1204		1.660
ST RD..12 038 ISO	✓	✓	EMR D32 W32 L200 Z03 RD..1204		1.787
ST RD..12 039 ISO	✓	✓	EMR D25 W25 L200 Z02 RD..1204		1.575

RPMW 1003 ISO



KOD	Stok Stock	Inter Cooland	Kesici Uç Uyumluluğu / Insert Suitability	FİYAT PRICE
			ISO RPMW 1003	TL
ST RPMW 10 001 ISO	✓	✓	EMR D20 W20 L150 Z02 RPMW 1003	1.363
ST RPMW 10 002 ISO	✓	✓	EMR D25 W25 L150 Z02 RPMW 1003	1.449

RPMT 1204 TNGLY



KOD	Stok Stock	Inter Cooland	Kesici Uç Uyumluluğu / Insert Suitability	FİYAT PRICE
			TNGLY RPMT 1204	TL
ST RPMT 12 001 TNG	✓	✓	EMR D25 W25 L160 Z02 RPMT 1204	1.492
ST RPMT 12 002 TNG	✓	✓	EMR D30 W25 L160 Z03 RPMT 1204	1.618
ST RPMT 12 003 TNG	✓	✓	EMR D32 W32 L160 Z03 RPMT 1204	1.618

RPMT 10T3 TNGLY



KOD	Stok Stock	Inter Cooland	Kesici Uç Uyumluluğu / Insert Suitability	FİYAT PRICE
			TNGLY RPMT 10T3	TL
ST RPMT 10T3 001 TNG	✓	✓	EMR D20 W20 L160 Z02 RPMT 10T3	1.403
ST RPMT 10T3 003 TNG	✓	✓	EMR D25 W25 L160 Z02 RPMT 10T3	1.492
ST RPMT 10T3 004 TNG	✓	✓	EMR D30 W25 L160 Z03 RPMT 10T3	1.618
ST RPMT 10T3 005 TNG	✓	✓	EMR D32 W32 L160 Z03 RPMT 10T3	1.618

RDMX 0802 SNG



KOD	Stok Stock	Inter Cooland	Kesici Uç Uyumluluğu / Insert Suitability	FİYAT PRICE
			SNG RDMX 0802	TL
ST RDMX 08 001 SNG	✓	✓	EMR D16 W16 L160 Z02 RDMX 0802	1.241
ST RDMX 08 002 SNG	✓	✓	EMR D20 W20 L160 Z02 RDMX 0802	1.326

B.ST



KOD	Stok Stock	Inter Cooland	Kesici Uç Uyumluluğu / Insert Suitability		FIYAT PRICE
			HRN B.ST		TL
A05.0016.07.B.ST HRN	✓	✓	A05.0016.07.B.ST		1.194
A07.0020.07.B.ST HRN	✓	✓	A07.0020.07.B.ST		1.194
A08.0020.09.B.ST HRN	✓	✓	A08.0020.09.B.ST		1.194
A09.0025.07.B.ST HRN	✓	✓	A09.0025.07.B.ST		1.194

HD 12



KOD	Stok Stock	Inter Cooland	Kesici Uç Uyumluluğu / Insert Suitability		FIYAT PRICE
			ISO		TL
HD 12 06 R 001 HRN	✓	X	HD 12-6 R		1.023
HD 12 07 R 002 HRN	✓	X	HD 12-7 R		1.023
HD 12 08 R 003 HRN	✓	X	HD 12-8 R		1.023
HD 12 09 R 004 HRN	✓	X	HD 12-9 R		1.023
HD 12 11 R 005 HRN	✓	X	HD 12-11 R		1.023

DİŞ TARAĞI



KOD	Stok / Stock	Kesici Uç Uyumluluğu / Insert Suitability		FIYAT PRICE
		DİŞ TARAĞI CPT - C14 - C21		TL
DT C14 001	✓	DT D16 W16 L120 CPT C14		1.660
DT C21 002	✓	DT D18 W20 L100 CPT C21		1.660
DT C21 003	✓	DT D21 W25 L120 CPT C21		1.700
DT C21 004	✓	DT D25 W25 L120 CPT C21		1.700

VİDALI TAKIM TUTUCU



KOD	Stok Stock	Inter Cooland	Kesici Uç Uyumluluğu / Insert Suitability		FIYAT PRICE
			VİDALI UZATMA		TL
VTU M12 001	✓	✓	VTU D25 M12 L120		1.829
VTU M12 002	✓	✓	VTU D25 M12 L160		1.958
VTU M12 003	✓	✓	VTU D25 M12 L200		2.512
VTU M16 004	✓	✓	VTU D32 M16 L120		1.829
VTU M16 005	✓	✓	VTU D32 M16 L160		2.085
VTU M16 006	✓	✓	VTU D32 M16 L200		2.765
VTU M16 007	✓	✓	VTU D32 M16 L250		2.822



HIGH FEED FINISH TAKIMLARI
HIGH FEED FINISH TOOLS

**KÜRE 08/10/12/16
20/25/30/32 WLTR**



KOD	Stok / Stock	Kesici Uç Uyumluluğu / Insert Suitability	FİYAT PRICE
		WLTR P3201/P3204	TL
ST P3201 002 WLTR	✓	BMR D10 W12 L130 P3201-D10	1.363
ST P3204 003 WLTR	✓	BMR D12 W12 L130 P3204-D12	1.449
ST P3204 004 WLTR	✓	BMR D16 W16 L140 P3204-D16	1.492
ST P3204 005 WLTR	✓	BMR D20 W20 L160 P3204-D20	1.787
ST P3201 006 WLTR	✓	BMR D25 W25 L160 P3201-D25	1.787

ROHX 12/16/20 ZCC



KOD	Stok / Stock	Kesici Uç Uyumluluğu / Insert Suitability	FİYAT PRICE
		ZCC ROHX 12/16/20	TL
ST ROHX 16 002 ZCC	✓	BMR D16 W16 L160 ROHX 1604	1.550
ST ROHX 16 003 ZCC	✓	BMR D16 W16 L200 ROHX 1604	1.638
ST ROHX 16 004 ZCC	✓	BMR D16 W16 L250 ROHX 1604	1.901
ST ROHX 20 005 ZCC	✓	BMR D20 W20 L160 ROHX 2005	1.726
ST ROHX 20 006 ZCC	✓	BMR D20 W20 L200 RDHX 2005	1.857
ST ROHX 20 008 ZCC	✓	BMR D20 W25 L240 ROHX 2005	1.992

**ZOHX 12/16/20
25/32 ZCC**



KOD	Stok / Stock	Kesici Uç Uyumluluğu / Insert Suitability	FİYAT PRICE
		ZCC ZOHX 12/16/20/25/32	TL
ST ZOHX 16 002 ZCC	✓	BMR D16 W16 L180 ZOHX 1604	1.550
ST ZOHX 20 003 ZCC	✓	BMR D20 W20 L200 ZOHX 2005	1.726
ST ZOHX 25 004 ZCC	✓	BMR D25 W25 L250 ZOHX 2506	1.857
ST ZOHX 32 005 ZCC	✗	BMR D32 W32 L250 ZOHX 3207	2.522



FREZELEME TAKIMLARI FACE MILLING

**CCMT 06/09/12
ISO DISK FREZE**

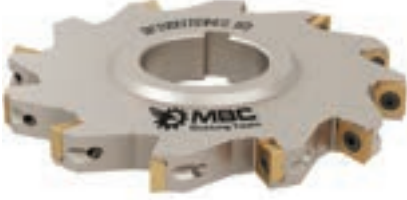

KOD	Stok / Stock	Kesici Uç Uyumluluğu / Insert Suitability		FİYAT PRICE TL
		ISO CCMT 06/09/12		
DKF 001 ISO	✓	DKF D80X8 Z10 W27 CC..0602		3.063
DKF 002 ISO	✓	DKF D100X8 Z12 W32 CC..0602		3.488
DKF 003 ISO	✓	DKF D125X8 Z14 W40 CC..0602		4.252
DKF 004 ISO	✓	DKF D160X8 Z16 W40 CC..0602		5.102
DKF 005 ISO	✓	DKF D80X10 Z10 W27 CC..0602		3.063
DKF 006 ISO	✓	DKF D100X10 Z12 W32 CC..0602		3.488
DKF 007 ISO	✓	DKF D125X10 Z14 W40 CC..0602		4.252
DKF 008 ISO	✓	DKF D160X10 Z16 W40 CC..0602		5.102
DKF 009 ISO	✓	DKF D80X12 Z08 W27 CC..09T3		3.063
DKF 010 ISO	✓	DKF D100X12 Z10 W32 CC..09T3		3.488
DKF 011 ISO	✓	DKF D125X12 Z12 W40 CC..09T3		4.252
DKF 012 ISO	✓	DKF D160X12 Z14 W40 CC..09T3		5.102
DKF 013 ISO	✓	DKF D80X14 Z08 W27 CC..09T3		3.063
DKF 014 ISO	✓	DKF D100X14 Z10 W32 CC..09T3		3.488
DKF 015 ISO	✓	DKF D125X14 Z12 W40 CC..09T3		4.252
DKF 016 ISO	✓	DKF D160X14 Z14 W40 CC..09T3		5.102
DKF 017 ISO	✓	DKF D80X16 Z06 W27 CC..1204		3.063
DKF 018 ISO	✓	DKF D100X16 Z08 W32 CC..1204		3.488
DKF 019 ISO	✓	DKF D125X16 Z10 W40 CC..1204		4.252
DKF 020 ISO	✓	DKF D160X16 Z12 W40 CC..1204		5.102

**APKT 1003 ISO
HELİSEL FREZE**



KOD	Stok Stock	Inter Cooland	Kesici Uç Uyumluluğu / Insert Suitability		FİYAT PRICE TL
			ISO APKT 1003		
S HF AP.. 10 001 ISO	✓	✓	HF90 D20 W20 L110 Z 2X3 AP..10		3.404
S HF AP.. 10 002 ISO	✓	✓	HF90 D25 W25 L120 Z 2X4 AP..10		4.212
S HF AP.. 10 003 ISO	✓	✓	HF90 D32 W32 L120 Z 3X5 AP..10		5.529
S HF AP.. 10 004 ISO	✓	✓	HF90 D40 W32 L130 Z 3X6 AP..10		5.955

LNKT 1206 ZCC



KOD	Stok Stock	Inter Cooland	Kesici Uç Uyumluluğu / Insert Suitability		FİYAT PRICE TL
			ZCC LNKT 1206		
TK HF LNKT 12 002 ZCC	✓	✓	HF90 50X4X4 027 LNKT 1206		7.963
TK HF LNKT 12 003 ZCC	✓	✓	HF90 50X4X4 022 LNKT 1206		7.963

**AP.. 1604 ISO
HELİSEL FREZE**



KOD	Stok Stock	Inter Cooland	Kesici Uç Uyumluluğu / Insert Suitability		FIYAT PRICE
			ISO AP.. 1604		TL
TK HF 001 ISO	✓	✗	HF90 50X3X4 AP..16		7.230
TK HF 002 ISO	✓	✗	HF90 63X4X4 AP..16		8.080
TK HF 003 ISO	✓	✗	HF90 80X5X5 AP..16		8.930

**TCMT 11/16 ISO
HAVŞA MATKABI**



KOD	Stok Stock	Inter Cooland	Kesici Uç Uyumluluğu / Insert Suitability		FIYAT PRICE
			ISO TCMT 11/16		TL
HM 001 ISO	✓	✗	HM45 D4-15 W16 L100 Z01 TC..11		809
HM 002 ISO	✓	✗	HM45 D14-25 W25 L100 Z02 TC..11		809
HM 003 ISO	✓	✗	HM45 D16-30 W12 L100 Z03 TC..11		809
HM 004 ISO	✓	✗	HM45 D21-35 W12 L100 Z03 TC..11		894
HM 005 ISO	✓	✗	HM45 D5-23 W16 L100 Z01 TC..16		829
HM 006 ISO	✓	✗	HM45 D10-31 W16 L100 Z02 TC..16		829
HM 007 ISO	✓	✗	HM45 D14-35 W20 L100 Z02 TC..16		829
HM 009 ISO	✓	✗	HM45 D22-43 W25 L100 Z03 TC..16		914
HM 010 ISO	✓	✗	HM45 D30-50 W25 L100 Z03 TC..16		1.322
HM 012 ISO	✓	✗	HM60 D6-20 W16 L100 Z01 TC..16		745
HM 013 ISO	✓	✗	HM60 D20-35 W20 L100 Z02 TC..16		809
HM 014 ISO	✓	✗	HM60 D24-40 W25 L100 Z02 TC..16		1.322

**CCMT 06/09 ISO
T FREZE**



KOD	Stok Stock	Inter Cooland	Kesici Uç Uyumluluğu / Insert Suitability		FIYAT PRICE
			ISO CCMT 06/09		TL
TF 000 ISO	X	X	TF90 D14X7 W16 Z02 SR.050204		1.275
TF 002 ISO	X	X	TF90 D20X9 W16 Z02 CCMT 06		1.363
TF 003 ISO	✓	X	TF90 D21X9 W16 Z02 CCMT 06		1.363
TF 004 ISO	✓	X	TF90 D24X10 W20 Z02 CCMT 06		1.449
TF 005 ISO	✓	X	TF90 D25X11 W25 Z02 CCMT 06		1.449
TF 006 ISO	✓	X	TF90 D25X12 W25 Z02 CCMT 06		1.449
TF 007 ISO	✓	X	TF90 D32X8 W25 Z04 CCMT 06		1.872
TF 008 ISO	✓	X	TF90 D32X10 W25 Z04 CCMT 06		1.872
TF 009 ISO	✓	X	TF90 D63X8 W32 Z08 CCMT 06		3.189
TF 010 ISO	✓	X	TF90 D30X12 W25 Z02 CCMT 09		1.872
TF 011 ISO	✓	X	TF90 D32X14 W25 Z02 CCMT 09		1.872
TF 012 ISO	✓	X	TF90 D40X16 W32 Z04 CCMT 09		2.002
TF 013 ISO	✓	X	TF90 D40X18 W32 Z04 CCMT 09		2.127
TF 014 ISO	✓	X	TF90 D32X12 W25 Z02 CCMT 09		1.872
TF 015 ISO	✓	X	TF90 D40X12 W32 Z04 CCMT 09		2.002
TF 016 ISO	✓	X	TF90 D50X12 W32 Z04 CCMT 09		2.512
TF 017 ISO	✓	X	TF90 D50X16 W32 Z04 CCMT 09		2.550
TF 018 ISO	✓	X	TF90 D42X8 W25 Z04 CCMT 0602		2.002
TF 019 (L) ISO	✓	X	TF90 D32X8,5 W20 Z04 CCMT 06 (L)		1.700
TF 020 (R) ISO	✓	X	TF90 D32X8,5 W20 Z04 CCMT 06 (R)		1.700
TF 022 ISO	✓	X	TF90 D17X9 W16 Z02 CCMT 0602		1.363

**DCMT 11 55° ISO
KIRLANGIÇ FREZE**

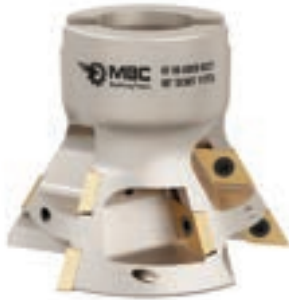

KOD	Stok Stock	Inter Cooland	Kesici Uç Uyumluluğu / Insert Suitability		FIYAT PRICE
			ISO		TL
TK KRF 55 001 ISO	✓	X	KF 55 80X9 027 55° DCMT 11T3		7.658
TK KRF 60 002 ISO	✓	X	KF 60 80X9 027 60° DCMT 11T3		7.658
TK KRF 55 003 ISO	✓	X	KF 55 50X4 022 60° DCMT 11T3		5.318



TARAMA KAFALARI FACE MILLING

90° TPKN 16 ISO



KOD	Stok Stock	Inter Cooland	Kesici Uç Uyumluluğu / Insert Suitability	FIYAT PRICE
			ISO TPKN 1603	TL
TK TPKN 16 001 ISO	✓	✗	EM90 50X3 022 TPKN 1603	1.275
TK TPKN 16 002 ISO	✓	✗	EM90 63X4 022 TPKN 1603	1.532
TK TPKN 16 003 ISO	✓	✗	EM90 80X5 032 TPKN 1603	1.829
TK TPKN 16 004 ISO	✓	✗	EM90 100X6 032 TPKN 1603	2.044

90° TPKN 22 ISO



KOD	Stok Stock	Inter Cooland	Kesici Uç Uyumluluğu / Insert Suitability	FIYAT PRICE
			ISO TP.. 2204	TL
TK TPKN 22 001 ISO	✓	✗	EM90 63X3 022 TPKN 2204	1.532
TK TPKN 22 002 ISO	✓	✗	EM90 80X4 027 TPKN 2204	1.872
TK TPKN 22 003 ISO	✓	✗	EM90 80X4 032 TPKN 2204	1.872
TK TPKN 22 004 ISO	✓	✗	EM90 100X5 032 TPKN 2204	2.297
TK TPKN 22 005 ISO	✓	✗	EM90 125X6 032 TPKN 2204	3.458
TK TPKN 22 006 ISO	✓	✗	EM90 125X6 040 TPKN 2204	3.458
TK TPKN 22 007 ISO	✓	✗	EM90 160X7 040 TPKN 2204	4.043
TK TPKN 22 008 ISO	✓	✗	EM90 200X8 060 TPKN 2204	6.890
TK TPKN 22 009 ISO	✓	✗	EM90 250X10 060 TPKN 2204	9.527

90° AP.. 1003 ISO



KOD	Stok Stock	Inter Cooland	Kesici Uç Uyumluluğu / Insert Suitability	FIYAT PRICE
			ISO AP.. 1003	TL
TK AP..10 001 ISO	✓	✗	EM90 40X5 016 APKT 1003	1.064
TK AP..10 001 ISO (S)	✓	✓	EM90 40X5 016 APKT 1003 inter cooland	1.233
TK AP..10 002 ISO	✓	✗	EM90 50X6 022 APKT 1003	1.403
TK AP..10 002 ISO (S)	✓	✓	EM90 50X6 022 APKT 1003 inter cooland	1.532
TK AP..10 003 ISO	✓	✗	EM90 63X7 022 APKT 1003	1.618
TK AP..10 003 ISO (S)	✓	✓	EM90 63X7 022 APKT 1003 inter cooland	1.748
TK AP..10 004 ISO	✓	✗	EM90 80X8 027 APKT 1003	1.872
TK AP..10 004 ISO (S)	✓	✓	EM90 80X8 027 APKT 1003 inter cooland	2.044
TK AP..10 005 ISO	✓	✗	EM90 100X9 032 APKT 1003	2.213
TK AP..10 005 ISO (S)	✓	✓	EM90 100X9 032 APKT 1003 inter cooland	2.425

90° APKT 16 ISO



KOD	Stok Stock	Inter Cooland	Kesici Uç Uyumluluğu / Insert Suitability		FIYAT PRICE
			ISO APKT 1604		TL
TK AP..16 001 ISO	✓	X	EM90 40X4 016 APKT 1604		1.064
TK AP..16 001 ISO (S)	✓	✓	EM90 40X4 016 APKT 1604 inter cooland		1.194
TK AP..16 002 ISO	✓	X	EM90 50X4 022 APK T1604		1.363
TK AP..16 002 ISO (S)	✓	✓	EM90 50X4 022 APKT 1604 inter cooland		1.449
TK AP..16 003 ISO	✓	X	EM90 50X5 022 APKT 1604		1.363
TK AP..16 003 ISO (S)	✓	✓	EM90 50X5 022 APKT 1604 inter cooland		1.449
TK AP..16 004 ISO	✓	X	EM90 63X5 022 APKT 1604		1.575
TK AP..16 004 ISO (S)	✓	✓	EM90 63X5 022 APKT 1604 inter cooland		1.660
TK AP..16 005 ISO	✓	X	EM90 80X6 027 APKT 1604		1.917
TK AP..16 005 ISO (S)	✓	✓	EM90 80X6 027 APKT 1604 inter cooland		1.917
TK AP..16 006 ISO	✓	X	EM90 80X6 032 APKT 1604		1.917
TK AP..16 006 ISO (S)	✓	✓	EM90 80X6 032 APKT 1604 inter cooland		1.917
TK AP..16 007 ISO	✓	X	EM90 80X7 027 APKT 1604		1.917
TK AP..16 008 ISO	✓	X	EM90 100X8 032 APKT 1604		2.213
TK AP..16 008 ISO (S)	✓	✓	EM90 100X8 032 APKT 1604 inter cooland		2.340
TK AP..16 011 ISO	✓	X	EM90 125X9 040 APKT 1604		3.488
TK AP..16 012 ISO	✓	X	EM90 160X10 040 APKT 1604		4.252
TK AP..16 013 ISO	✓	X	EM90 200X12 060 APKT 1604		7.230
TK AP..16 014 ISO	✓	X	EM90 250X14 060 APKT 1604		9.780

90° VCGT 2205 ISO



KOD	Stok Stock	Inter Cooland	Kesici Uç Uyumluluğu / Insert Suitability		FIYAT PRICE
			ISO VCGT 2205		TL
TK VCGT 22 001 ISO	✓	✓	EM90 50X3 022 VCGT 2205		1.403
TK VCGT 22 002 ISO	✓	✓	EM90 63X4 022 VCGT 2205		1.917
TK VCGT 22 004 ISO	✓	✓	EM90 80X5 027 VCGT 2205		2.085

90° TPKT 2205 DRCP



KOD	Stok Stock	Inter Cooland	Kesici Uç Uyumluluğu / Insert Suitability		FIYAT PRICE
			DRCP TPKT 2205		TL
TK TPKT 22 001 DRCP	✓	X	EM90 63X3 022 TPKT 2205		1.787
TK TPKT 22 002 DRCP	✓	X	EM90 80X4 027 TPKT 2205		2.255
TK TPKT 22 003 DRCP	✓	X	EM90 100X5 032 TPKT 2205		2.640
TK TPKT 22 004 DRCP	✓	X	EM90 125X6 040 TPKT 2205		3.704

90° ANKX 09 I



KOD	Stok Stock	Inter Cooland	Kesici Uç Uyumluluğu / Insert Suitability	FİYAT PRICE
			I ANKX 09	TL
TK ANKX 09 002 ISO (S)	✓	✓	EM90 50X7 022 ANKX 09 inter cooland	1.700

90° AN.. 1205 I



KOD	Stok Stock	Inter Cooland	Kesici Uç Uyumluluğu / Insert Suitability	FİYAT PRICE
			I ANKX 1205	TL
TK ANKX 12 001 I	✓	✓	EM90 50X5 022 ANKX 1205	1.488
TK ANKX 12 002 I	✓	✓	EM90 63X6 022 ANKX 1205	1.650
TK ANKX 12 003 I	✓	✓	EM90 80X7 027 ANKX 1205	2.097
TK ANKX 12 004 I	✓	✓	EM90 100X8 032 ANKX 1205	2.617
TK ANKX 12 005 I	✓	X	EM90 125X10 040 ANKX 1205	3.530

90° TP.. 1003 I



KOD	Stok Stock	Inter Cooland	Kesici Uç Uyumluluğu / Insert Suitability	FİYAT PRICE
			I TPKT 1003	TL
TK TPKT 10 001 I	✓	✓	EM90 40X5 016 TPKT 1003	1.917
TK TPKT 10 002 I	✓	✓	EM90 50X6 022 TPKT 1003	2.297
TK TPKT 10 003 I	✓	✓	EM90 63X7 022 TPKT 1003	2.512

90° TD.. 1505 I



KOD	Stok Stock	Inter Cooland	Kesici Uç Uyumluluğu / Insert Suitability	FIYAT PRICE
			I TD.. 1505	TL
TK TD.. 15 001 I	✓	✗	EM90 50X4 022 TD.. 1505	1.787
TK TD.. 15 002 I	✓	✗	EM90 63X5 022 TD.. 1505	2.085

90° AD.. 1505 I



KOD	Stok Stock	Inter Cooland	Kesici Uç Uyumluluğu / Insert Suitability	FIYAT PRICE
			I AD.. 15	TL
TK AD.. 15 001 I	✓	✓	EM90 40X4 016 AD.. 15	1.203
TK AD.. 15 002 I	✓	✓	EM90 50X5 022 AD.. 15	1.449
TK AD.. 15 003 I	✓	✓	EM90 63X6 022 AD.. 15	1.700
TK AD.. 15 004 I	✓	✓	EM90 80X7 027 AD.. 15	2.213
TK AD.. 15 005 I	✓	✓	EM90 100X8 032 AD.. 15	2.617

90° LN.. 0804 I



KOD	Stok Stock	Inter Cooland	Kesici Uç Uyumluluğu / Insert Suitability	FIYAT PRICE
			I LN.. 0804	TL
TK LN.. 08 001 I	✓	✓	EM90 50X5 022 LN..0804	1.492
TK LN.. 08 002 I	✓	✓	EM90 63X7 022 LN.. 0804	1.787

90° LNGX 1307 WLTR



KOD	Stok Stock	Inter Cooland	Kesici Uç Uyumluluğu / Insert Suitability	FIYAT PRICE
			WLTR LNGX 1307	TL
TK LNGX 13 004 WLTR	✓	✓	EM90 100X8 032 LNGX 1307	2.893
TK LNGX 13 006 WLTR	✓	✗	EM90 160X8 040 LNGX 1307	5.102
TK LNGX 13 007 WLTR	✓	✓	EM90 80X7 027 LNGX 1307	2.213
TK LNGX 13 008 WLTR	✓	✓	EM90 50X4 022 LNGX 1307	1.575
TK LNGX 13 009 WLTR	✓	✓	EM90 63X5 022 LNGX 1307	1.787
TK LNGX 13 010 WLTR	✓	✗	EM90 125X10 040 LNGX 1307	3.829

90° LNHU 1306 WLTR



KOD	Stok Stock	Inter Cooland	Kesici Uç Uyumluluğu / Insert Suitability	FIYAT PRICE
			WLTR LNHU 1306	TL
TK LNHU 13 001 WLTR	✓	✓	EM90 40X4 016 LNHU 1306	1.575
TK LNHU 13 002 WLTR	✓	✓	EM90 50X5 022 LNHU 1306	1.820
TK LNHU 13 003 WLTR	✓	✓	EM90 63X6 022 LNHU 1306	1.950
TK LNHU 13 004 WLTR	✓	✓	EM90 80X7 027 LNHU 1306	2.259
TK LNHU 13 005 WLTR	✓	✓	EM90 100X9 032 LNHU 1306	2.935

90° ADMT 1204 WLTR



KOD	Stok Stock	Inter Cooland	Kesici Uç Uyumluluğu / Insert Suitability	FIYAT PRICE
			WLTR ADMT 1204	TL
TK ADMT 12 001 WLTR	✓	✗	EM90 40X4 016 ADMT 1204	1.660
TK ADMT 12 002 WLTR	✓	✗	EM90 50X5 022 ADMT 1204	1.958
TK ADMT 12 003 WLTR	✓	✗	EM90 63X6 022 ADMT 1204	2.213

90° P2840 WLTR



KOD	Stok Stock	Inter Cooland	Kesici Uç Uyumluluğu / Insert Suitability	FIYAT PRICE
			WLTR P2840	TL
TK P2840 63 001 WLTR	✓	✓	EM90 40X4 016 P-2840	1.275
TK P2840 63 002 WLTR	✓	✓	EM90 50X5 022 P-2840	1.492

90° SPMT 1204 WLTR



KOD	Stok Stock	Inter Cooland	Kesici Uç Uyumluluğu / Insert Suitability	FIYAT PRICE
			WLTR SPMT 1204	TL
TK SPMT 12 002 ISO	✓	✓	EM90 50X4 022 SPMT 1204	1.449
TK SPMT 12 003 ISO	✓	✓	EM90 63X5 022 SPMT 1204	1.660

90° LNMX 1006/1510 KRLY



KOD	Stok Stock	Inter Cooland	Kesici Uç Uyumluluğu / Insert Suitability	FIYAT PRICE
			KRLY LNMX 1006/1510	TL
TK LNMX 10 001 KRLY	✓	✓	EM90 40X4 016 LNMX 1006	1.275
TK LNMX 10 002 KRLY	✓	✓	EM90 40X5 016 LNMX 1006	1.317
TK LNMX 10 003 KRLY	✓	✓	EM90 50X6 022 LNMX 1006	1.449
TK LNMX 15 004 KRLY	✓	✓	EM90 50X4 022 LNMX 1510	1.532
TK LNMX 15 005 KRLY	✓	✓	EM90 63X6 022 LNMX 1510	1.917
TK LNMX 15 006 KRLY	✓	✓	EM90 80X7 027 LNMX 1510	2.127
TK LNMX 15 007 KRLY	✓	✓	EM90 100X8 032 LNMX 1510	2.550
TK LNMX 15 008 KRLY	✓	✗	EM90 125X10 040 LNMX 1510	3.404
TK LNMX 15 009 KRLY	✓	✗	EM90 160X12 040 LNMX 1510	4.810

90° XNKT 0805 KRLY



KOD	Stok Stock	Inter Cooland	Kesici Uç Uyumluluğu / Insert Suitability	FIYAT PRICE
			KRLY XNKT 0805	TL
TK XNKT 08 001 KRLY	✓	✓	EM90 40X4 016 XNKT 0805	1.492
TK XNKT 08 002 KRLY	✓	✓	EM90 50X5 022 XNKT 0805	1.787
TK XNKT 08 003 KRLY	✓	✓	EM90 63X6 022 XNKT 0805	2.085
TK XNKT 08 004 KRLY	✓	✓	EM90 80X7 027 XNKT 0805	2.512
TK XNKT 08 005 KRLY	✓	✓	EM90 100X8 032 XNKT 0805	2.978

90° APMT 11T3 KRLY



KOD	Stok Stock	Inter Cooland	Kesici Uç Uyumluluğu / Insert Suitability	FIYAT PRICE
			KRLY APMT 11T3	TL
TK APMT 11 000 KRLY	✓	✓	EM90 40X5 016 APMT 11T3	1.575
TK APMT 11 001 KRLY	✓	✓	EM90 40X6 016 APMT 11T3	1.609
TK APMT 11 002 KRLY	✓	✓	EM90 50X6 022 APMT 11T3	1.958
TK APMT 11 003 KRLY	✓	✓	EM90 63X7 022 APMT 11T3	2.127

90° APMT 1604 KRLY



KOD	Stok Stock	Inter Cooland	Kesici Uç Uyumluluğu / Insert Suitability	FIYAT PRICE
			KRLY APMT 1604	TL
TK APMT 16 001 KRLY	✓	✓	EM90 50X5 022 APMT 1604	1.618
TK APMT 16 003 KRLY	✓	✓	EM90 63X6 022 APMT 1604	1.829
TK APMT 16 004 KRLY	✓	✓	EM90 80X7 027 APMT 1604	2.044
TK APMT 16 005 KRLY	✓	✓	EM90 100X8 032 APMT 1604	2.467

90° LNGU 1607 PRMT



KOD	Stok Stock	Inter Cooland	Kesici Uç Uyumluluğu / Insert Suitability	FIYAT PRICE
			PRMT LNGU 1607	TL
TK LNGU 16 002 PRMT	✓	✓	EM90 80X4 027 LNGU 1607	2.085
TK LNGU 16 003 PRMT	✓	✓	EM90 100X5 032 LNGU 1607	2.340
TK LNGU 16 004 PRMT			EM90 63X5 022 LNGU 1607	1.829

90° ADMX 1606 PRMT



KOD	Stok Stock	Inter Cooland	Kesici Uç Uyumluluğu / Insert Suitability	FIYAT PRICE
			PRMT ADMX 1606	TL
TK ADMX 16 001 PRMT	✓	X	EM90 50X4 022 ADMX 1606	1.609
TK ADMX 16 002 PRMT	✓	X	EM90 50X5 022 ADMX 1606	1.642
TK ADMX 16 003 PRMT	✓	X	EM90 80X7 027 ADMX 1606	2.080
TK ADMX 16 005 PRMT	✓	X	EM90 100X8 032 ADMX 1606	2.512

90° XN..0403 SCO-VNDRT



KOD	Stok Stock	Inter Cooland	Kesici Uç Uyumluluğu / Insert Suitability	FIYAT PRICE
			SCO - VNDR XNEX 0403	TL
TK XNEX 04 001 SC-VD	✓	✓	EM90 40X6 016 XNEX 0403	1.958
TK XNEX 04 002 SC-VD	✓	✓	EM90 50X7 022 XNEX 0403	2.127

90° LNGX 1205 VNDRT



KOD	Stok Stock	Inter Cooland	Kesici Uç Uyumluluğu / Insert Suitability	FİYAT PRICE
			PRMT/VNDRT LNGX 1205	TL
TK LNGX 12 001 VNDRT	✓	✓	EM90 40X4 016 LNGX 1205	1.363
TK LNGX 12 002 VNDRT	✓	✓	EM90 50X5 022 LNGX 1205	1.575
TK LNGX 12 003 VNDRT	✓	✓	EM90 63X6 022 LNGX 1205	1.829
TK LNGX 12 004 VNDRT	✓	✓	EM90 80X5 032 LNGX 1205	2.127

90° ANHG 1005 VNDRT



KOD	Stok Stock	Inter Cooland	Kesici Uç Uyumluluğu / Insert Suitability	FİYAT PRICE
			VNDRT ANHG 1005	TL
TK ANHG 10 001 VNDRT	✓	✓	EM90 40X4 016 ANHG 1005	1.618
TK ANHG 10 002 VNDRT	✓	✓	EM90 50X5 022 ANHG 1005	1.700
TK ANHG 10 003 VNDRT	✓	✓	EM90 63X5 022 ANHG 1005	2.023
TK ANHG 10 004 VNDRT	✓	✓	EM90 63X7 022 ANHG 1003	2.127
TK ANHG 10 006 VNDRT	✓	✓	EM90 100X7 032 ANHG 1005	2.853
TK ANHG 10 007 VNDRT	✓	✓	EM90 100X8 032 ANHG 1005	2.853

90° XNEX 0806 VNDRT



KOD	Stok Stock	Inter Cooland	Kesici Uç Uyumluluğu / Insert Suitability	FİYAT PRICE
			SCO-VNDR XNEX 0806	TL
TK XNEX 08 002 SC-VD	✓	✓	EM90 50X4 022 XNEX 0806	1.829
TK XNEX 08 003 SC-VD	✓	✓	EM90 63X5 022 XNEX 0806	2.127
TK XNEX 08 004 SC-VD	✓	✓	EM90 80X7 027 XNEX 0806	2.425
TK XNEX 08 005 SC-VD	✓	✓	EM90 100X8 032 XNEX 0806	2.978
TK XNEX 08 006 SC-VD	✓	✗	EM90 160X12 040 XNEX 0806	5.102

90° ANHG 1607 VNDRT



KOD	Stok Stock	Inter Cooland	Kesici Uç Uyumluluğu / Insert Suitability	FIYAT PRICE
			VNDRT ANHG 1607	TL
TK ANHG 16 001 VNDRT	✓	✓	EM90 50X4 022 ANHG 1607	1.660
TK ANHG 16 002 VNDRT	✓	✓	EM90 63X4 022 ANHG 1607	2.044
TK ANHG 16 003 VNDRT	✓	✓	EM90 63X6 022 ANHG 1607	2.044
TK ANHG 16 004 VNDRT	✓	✓	EM90 80X5 027 ANHG 1607	2.550
TK ANHG 16 005 VNDRT	✓	✓	EM90 80X7 027 ANHG 1607	2.678
TK ANHG 16 006 VNDRT	✓	✓	EM90 100X8 032 ANHG 1607	2.914

90° ANHX 1607 TT



KOD	Stok Stock	Inter Cooland	Kesici Uç Uyumluluğu / Insert Suitability	FIYAT PRICE
			TT ANHX 1607	TL
TK ANHX 16 001 TT	✓	✓	EM90 50X5 022 ANHX 1607	1.700
TK ANHX 16 002 TT	✓	✓	EM90 63X6 022 ANHX 1607	1.917
TK ANHX 16 003 TT	✓	✓	EM90 80X7 027 ANHX 1607	2.527
TK ANHX 16 004 TT	✓	✓	EM90 100X8 032 ANHX 1607	2.765

90° WNMU 0806 SNG



KOD	Stok Stock	Inter Cooland	Kesici Uç Uyumluluğu / Insert Suitability	FIYAT PRICE
			SNG WNMU 0806	TL
TK WNMU 08 001 SNG	✓	✓	EM90 50X4 022 WNMU 0806	1.901
TK WNMU 08 002 SNG	✓	✓	EM90 52X4 022 WNMU 0806	1.901
TK WNMU 08 003 SNG	✓	✓	EM90 63X4 022 WNMU 0806	2.211
TK WNMU 08 004 SNG	✓	✓	EM90 63X5 022 WNMU 0806	2.211
TK WNMU 08 005 SNG	✓	✓	EM90 80X6 027 WNMU 0806	2.522
TK WNMU 08 006 SNG	✓	✗	EM90 125X8 040 WNMU 0806	3.981
TK WNMU 08 007 SNG	✓	✗	EM90 160X10 040 WNMU 0806	5.749
TK WNMU 08 008 SNG	✓	✓	EM90 100X7 032 WNMU 0806	3.096

90° APMT 1135 SNG



KOD	Stok Stock	Inter Cooland	Kesici Uç Uyumluluğu / Insert Suitability	FIYAT PRICE
			SNG APMT 1135	TL
TK APMT 1135 001 SNG	✓	✓	EM90 40X5 016 APMT 1135	1.592
TK APMT 1135 003 SNG	✓	✓	EM90 63X7 022 APMT 1135	1.857

90° 3PGX 1004 SNG



KOD	Stok Stock	Inter Cooland	Kesici Uç Uyumluluğu / Insert Suitability	FIYAT PRICE
			SNG 3PGX 1004	TL
TK 3PGX 10 001 SNG	✓	✓	EM90 40X5 016 3PGX 1004	1.673
TK 3PGX 10 002 SNG	✓	✓	EM90 50X6 022 3PGX 1004	1.892

90° 3PGX 1505 SNG



KOD	Stok Stock	Inter Cooland	Kesici Uç Uyumluluğu / Insert Suitability	FIYAT PRICE
			SNG 3PGX 1505	TL
TK 3PGX 15 001 SNG	✓	✓	EM90 50X5 022 3PGX 1505	1.682
TK 3PGX 15 002 SNG	✓	✓	EM90 63X6 022 3PGX 1505	1.901
TK 3PGX 15 003 SNG	✓	✓	EM90 80X7 027 3PGX 1505	2.035
TK 3PGX 15 005 SNG	✓	✗	EM90 125X10 040 3PGX 1505	3.892

90° XNMU 0606 SMTM



KOD	Stok Stock	Inter Cooland	Kesici Uç Uyumluluğu / Insert Suitability	FIYAT PRICE
			SMTM XNMU 0606	TL
TK XNMU 06 002 SMTM	✓	✓	EM90 63X7 022 XNMU 060608	2.104
TK XNMU 06 004 SMTM	✓	✓	EM90 80X9 027 XNMU 060608	2.539

90° XOMX 1204 SCO



KOD	Stok Stock	Inter Cooland	Kesici Uç Uyumluluğu / Insert Suitability	FIYAT PRICE
			SCO XOMX 1204	TL
TK XOMX 12 001 SCO	✓	✗	EM90 40X4 016 XOMX 1204	1.233
TK XOMX 12 002 SCO	✓	✗	EM90 50X5 022 XOMX 1204	1.532
TK XOMX 12 003 SCO	✓	✗	EM90 63X6 022 XOMX 1204	1.829
TK XOMX 12 004 SCO	✓	✗	EM90 80X8 027 XOMX 1204	2.085

3PKT 1505 TT



KOD	Stok Stock	Inter Cooland	Kesici Uç Uyumluluğu / Insert Suitability	FIYAT PRICE
			TT 3PKT 1505	TL
TK 3PKT 15 001 TT	✓	✓	EM90 50X4 022 3PKT 1505	1.717
TK 3PKT 15 002 TT	✓	✓	EM90 63X5 022 3PKT 1505	2.055
TK 3PKT 15 003 TT	✓	✓	EM90 80X7 027 3PKT 1505	2.515
TK 3PKT 15 004 TT	✓	✓	EM90 100X8 032 3PKT 1505	3.264

90° APKT 1204 TT



KOD	Stok Stock	Inter Cooland	Kesici Uç Uyumluluğu / Insert Suitability	FİYAT PRICE
			TT APKT 1204	TL
TK AP..12 001 TT	✓	✓	EM90 40X5 016 APKT 1204	1.512
TK AP..12 002 TT	✓	✓	EM90 50X6 022 APKT 1204	1.785
TK AP..12 003 TT	✓	✓	EM90 63X7 022 APKT 1204	2.023
TK AP..12 004 TT	✓	✓	EM90 80X8 027 APKT 1204	2.097

90° 3PKT 1004 TT



KOD	Stok Stock	Inter Cooland	Kesici Uç Uyumluluğu / Insert Suitability	FİYAT PRICE
			TT 3PKT 1004	TL
TK 3PKT 10 001 TT	✓	✓	EM90 40X4 016 3PKT 1004	1.829
TK 3PKT 10 002 TT	✓	✓	EM90 50X5 022 3PKT 1004	2.170
TK 3PKT 10 003 TT	✓	✓	EM90 63X8 022 3PKT 1004	2.467

90° APMT 1135 TT



KOD	Stok Stock	Inter Cooland	Kesici Uç Uyumluluğu / Insert Suitability	FİYAT PRICE
			TT APMT 1135	TL
TK APMT 1135 001 TT	✓	✓	EM90 40X5 016 APMT 1135	1.652
TK APMT 1135 003 TT	✓	✓	EM90 63X7 022 APMT 1135	2.127

90° 6NGU 0604 TT



KOD	Stok Stock	Inter Cooland	Kesici Uç Uyumluluğu / Insert Suitability	FIYAT PRICE
			TT 6NGU 0604	TL
TK 6NGU 06 001 TT	✓	✓	EM90 40X4 016 6NGU 0604	1.787
TK 6NGU 06 002 TT	✓	✓	EM90 50X5 022 6NGU 0604	2.002
TK 6NGU 06 003 TT	✓	✓	EM90 63X6 016 6NGU 0604	2.213

90° 6NGU 0905 TT



KOD	Stok Stock	Inter Cooland	Kesici Uç Uyumluluğu / Insert Suitability	FIYAT PRICE
			TT 6NGU 0905	TL
TK 6NGU 09 001 TT	✓	✓	EM90 50X5 022 6NGU 0905	1.660
TK 6NGU 09 002 TT	✓	✓	EM90 63X6 022 6NGU 0905	1.872
TK 6NGU 09 003 TT	✓	✓	EM90 80X7 027 6NGU 0905	2.255
TK 6NGU 09 004 TT	✓	✓	EM90 100X8 032 6NGU 0905	2.765
TK 6NGU 09 005 TT	✓	✗	EM90 125X10 040 6NGU 0905	3.488

90° AOMT 1236 MTSBSH



KOD	Stok Stock	Inter Cooland	Kesici Uç Uyumluluğu / Insert Suitability	FIYAT PRICE
			MTSBSH AOMT 1236	TL
TK AOMT 12 001 MTSBSH	✓	✓	EM90 40X6 016 AOMT 1236	1.618
TK AOMT 12 002 MTSBSH	✓	✓	EM90 50X7 022 AOMT 1236	1.917
TK AOMT 12 003 MTSBSH	✓	✓	EM90 63X8 022 AOMT 1236	2.170
TK AOMT 12 004 MTSBSH	✓	✓	EM90 80X9 027 AOMT 1236	2.467

90° SOMT 12T3 MTSBSH



KOD	Stok Stock	Inter Cooland	Kesici Uç Uyumluluğu / Insert Suitability	FİYAT PRICE
			MTSBSH SOMT 12T3	TL
TK SOMT 12 001 MTSBSH	✓	✓	EM90 50X4 022 SOMT 12T3	1.275
TK SOMT 12 002 MTSBSH	✓	✓	EM90 63X5 022 SOMT 12T3	1.618
TK SOMT 12 003 MTSBSH	✓	✓	EM90 80X6 027 SOMT 12T3	1.917
TK SOMT 12 004 MTSBSH	✓	✓	EM90 100X7 032 SOMT 12T3	2.127

90° AOMT 1848 MTSBSH



KOD	Stok Stock	Inter Cooland	Kesici Uç Uyumluluğu / Insert Suitability	FİYAT PRICE
			MTSBSH AOMT 1848	TL
TK AOMT 18 001 MTSBSH	✓	✗	EM90 50x4 022 AOMT 1848	1.635
TK AOMT 18 002 MTSBSH	✓	✗	EM90 63X6 022 AOMT 1848	1.844
TK AOMT 18 003 MTSBSH	✓	✗	EM90 80X6 027 AOMT 1848	2.320
TK AOMT 18 004 MTSBSH	✓	✗	EM90 100X8 032 AOMT 1848	2.735

90° XDGT 1550 MTSBSH



KOD	Stok Stock	Inter Cooland	Kesici Uç Uyumluluğu / Insert Suitability	FİYAT PRICE
			MTSBSH XDGT 1550	TL
TK XDGT 15 001 MTSBSH	✓	✗	EM90 50X4 022 XDGT 1550	1.660
TK XDGT 15 002 MTSBSH	✓	✗	EM90 63X5 022 XDGT 1550	1.872

90° XNMU 1607 MTSBSH



KOD	Stok Stock	Inter Cooland	Kesici Uç Uyumluluğu / Insert Suitability	FIYAT PRICE
			MTSBSH XNMU 1607	TL
TK XNMU 16 001 MTSBSH	✓	✓	EM90 50X5 022 XNMU 1607	1.660
TK XNMU 16 002 MTSBSH	✓	✓	EM90 63X6 022 XNMU 1607	1.872
TK XNMU 16 003 MTSBSH	✓	✓	EM90 80X7 027 XNMU 1607	2.127

90° R390 1806 SNDVK



KOD	Stok Stock	Inter Cooland	Kesici Uç Uyumluluğu / Insert Suitability	FIYAT PRICE
			SNDVK R390 1806	TL
TK R390 18 001 SNDVK	✓	✗	EM90 50X4 022 R390 1806	1.958
TK R390 18 002 SNDVK	✓	✗	EM90 63X5 022 R390 1806	2.127
TK R390 18 003 SNDVK	✓	✗	EM90 80X6 027 R390 1806	2.425
TK R390 18 004 SNDVK	✓	✗	EM90 100X8 032 R390 1806	2.550
TK R390 18 005 SNDVK	✓	✗	EM90 160X10 040 R390 1806	4.678
TK R390 18 006 SNDVK	✓	✗	EM90 125X9 040 R390 1806	4.212

90° R390 11T3 SNDVK



KOD	Stok Stock	Inter Cooland	Kesici Uç Uyumluluğu / Insert Suitability	FIYAT PRICE
			SNDVK R390 11T3	TL
TK R390 11 001 SNDVK	✓	✓	EM90 40X5 016 R390 11T3	1.194
TK R390 11 002 SNDVK	✓	✓	EM90 50X6 022 R390 11T3	1.492
TK R390 11 003 SNDVK	✓	✓	EM90 63X7 022 R390 11T3	1.700

90° ADKT 1704 SNDVK



KOD	Stok Stock	Inter Cooland	Kesici Uç Uyumluluğu / Insert Suitability	FIYAT PRICE
			SNDVK R390 ADKT 1704	TL
TK ADKT 17 001 SNDVK	✓	✗	EM90 40X4 016 R390 1704	1.153
TK ADKT 17 002 SNDVK	✓	✗	EM90 50X4 022 R390 1704	1.403
TK ADKT 17 003 SNDVK	✓	✗	EM90 63X5 022 R390 1704	1.700
TK ADKT 17 004 SNDVK	✓	✗	EM90 80X6 027 R390 1704	1.958

90° SE.. 1203 ZCC/SNDVK



KOD	Stok Stock	Inter Cooland	Kesici Uç Uyumluluğu / Insert Suitability	FIYAT PRICE
			ZCC/SNDVK SEET 1203	TL
TK SEET 12 001 ZCC	✓	✓	EM90 50X4 022 SEET 1203	1.504
TK SEET 12 002 ZCC	✓	✓	EM90 63X5 022 SEET 1203	1.859
TK SEET 12 003 ZCC	✓	✓	EM90 80X6 027 SEET 1203	2.112
TK SEET 12 004 ZCC	✓	✓	EM90 100X7 032 SEET 1203	2.518
TK SEET 12 005 ZCC	✓	✗	EM90 125X8 040 SEET 1203	3.498
TK SEET 12 006 ZCC	✓	✗	EM90 160X12 040 SEET 1203	5.305

90° ANGX 1506 ZCC



KOD	Stok Stock	Inter Cooland	Kesici Uç Uyumluluğu / Insert Suitability	FIYAT PRICE
			ZCC ANGX 1506	TL
TK ANGX 15 002 ZCC	✓	✓	EM90 40X4 016 ANGX 1506	1.417
TK ANGX 15 003 ZCC	✓	✓	EM90 50X4 022 ANGX 1506	1.537
TK ANGX 15 004 ZCC	✓	✓	EM90 63X5 022 ANGX 1506	1.638
TK ANGX 15 005 ZCC	✓	✓	EM90 80X6 027 ANGX 1506	1.992
TK ANGX 15 006 ZCC	✓	✓	EM90 100X8 032 ANGX 1506	2.652
TK ANGX 15 007 ZCC	✓	✗	EM90 125X9 040 ANGX 1506	4.335
TK ANGX 15 008 ZCC	✓	✗	EM90 160X12 040 ANGX 1506	5.749
TK ANGX 15 009 ZCC	✓	✗	EM90 200X14 060 ANGX 1506	10.615

90° ANGX 1105 ZCC



KOD	Stok Stock	Inter Cooland	Kesici Uç Uyumluluğu / Insert Suitability	FIYAT PRICE
			ZCC ANGX 1105	TL
TK ANGX 11 001 ZCC	✓	✓	EM90 50X6 022 ANGX 1105	1.458
TK ANGX 11 002 ZCC	✓	✓	EM90 63X7 022 ANGX 1105	1.817
TK ANGX 11 003 ZCC	✓	✓	EM90 40X4 016 ANGX 1105	1.326

90° APKT 11T3 ZCC



KOD	Stok Stock	Inter Cooland	Kesici Uç Uyumluluğu / Insert Suitability	FIYAT PRICE
			ZCC APKT 11T3	TL
TK APKT 11 001 ZCC	✓	✓	EM90 40X5 016 APKT 11T3	1.638
TK APKT 11 002 ZCC	✓	✓	EM90 50X6 022 APKT 11T3	2.035
TK APKT 11 003 ZCC	✓	✓	EM90 63X7 022 APKT 11T3	2.211

90° APKT 1604 ZCC



KOD	Stok Stock	Inter Cooland	Kesici Uç Uyumluluğu / Insert Suitability		FIYAT PRICE
			ZCC APKT 1604		TL
TK AP 16 001 ZCC	✓	✗	EM90 40X4 016 APKT 1604		1.281
TK AP 16 002 ZCC	✓	✗	EM90 50X5 022 APKT 1604		1.550
TK AP 16 003 ZCC	✓	✗	EM90 63X5 022 APKT 1604		1.682
TK AP 16 004 ZCC	✓	✗	EM90 80X7 027 APKT 1604		2.035
TK AP 16 005 ZCC	✓	✗	EM90 100X8 032 APKT 1604		2.301
TK AP 16 006 ZCC	✓	✗	EM90 125X9 040 APKT 1604		3.671

90° WNHU 0806 ZCC



KOD	Stok Stock	Inter Cooland	Kesici Uç Uyumluluğu / Insert Suitability		FIYAT PRICE
			ZCC WNHU 0806		TL
TK WNHU 08 001 ZCC	✓	✓	EM90 50X4 022 WNHU 0806		1.857
TK WNHU 08 002 ZCC	✓	✓	EM90 63X5 022 WNHU 0806		2.168
TK WNHU 08 003 ZCC	✓	✓	EM90 80X6 027 WNHU 0806		2.522
TK WNHU 08 008 ZCC	✓	✓	EM90 250X16 060 WNHU 0806		10.171
TK WNHU 08 009 ZCC	✓	✓	EM90 63X6 022 WNHU 0806		2.168
TK WNHU 08 010 ZCC	✓	✓	EM90 100X8 032 WNHU 0806		3.052
TK WNHU 08 012 ZCC	✓	✓	EM90 80X5 027 WNHU 0806		2.464

90° APKT 10T3 ZCC



KOD	Stok Stock	Inter Cooland	Kesici Uç Uyumluluğu / Insert Suitability		FIYAT PRICE
			ZCC APKT 10T3		TL
TK APKT 10 001 ZCC	✓	✗	EM90 40X5 016 APKT 10T3		1.281
TK APKT 10 002 ZCC	✓	✗	EM90 50X6 022 APKT 10T3		1.550
TK APKT 10 003 ZCC	✓	✗	EM90 63X7 022 APKT 10T3		1.726

90° APLX 1008 ZCC



KOD	Stok Stock	Inter Cooland	Kesici Uç Uyumluluğu / Insert Suitability	FİYAT PRICE
			ZCC APLX 1008	TL
TK APLX 10 001 ZCC	✓	✗	EM90 40X5 016 APLX 1008	1.281
TK APLX 10 002 ZCC	✓	✗	EM90 50X6 022 APLX 1008	1.550
TK APLX 10 003 ZCC	✓	✗	EM90 63X7 022 APLX 1008	1.682

90° LNKT 0804 ZCC



KOD	Stok Stock	Inter Cooland	Kesici Uç Uyumluluğu / Insert Suitability	FİYAT PRICE
			ZCC LNKT 0804	TL
TK LNKT 08 001 ZCC	✓	✓	EM90 40X5 016 LNKT 0804	1.417

90° LNKT 1206 ZCC



KOD	Stok Stock	Inter Cooland	Kesici Uç Uyumluluğu / Insert Suitability	FİYAT PRICE
			ZCC LNKT 1206	TL
TK LNKT 12 001 ZCC	✓	✓	EM90 50X5 022 LNKT 1206	1.537
TK LNKT 12 002 ZCC	✓	✓	EM90 63X6 022 LNKT 1206	1.768
TK LNKT 12 003 ZCC	✓	✓	EM90 80X7 027 LNKT 1206	2.168
TK LNKT 12 004 ZCC	✓	✓	EM90 100X9 032 LNKT 1206	2.875
TK LNKT 12 005 ZCC	✓	✗	EM90 125X11 040 LNKT 1206	3.627

90° EDPT 1404/1805 KNNMTL



KOD	Stok Stock	Inter Cooland	Kesici Uç Uyumluluğu / Insert Suitability	FIYAT PRICE
			KNNMTL EDPT 1404/1805	TL
TK EDPT 14 001 KNM	✓	✗	EM90 40X4 016 EDPT 1404	1.660
TK EDPT 14 002 KNM	✓	✗	EM90 50X5 022 EDPT 1404	1.958
TK EDPT 14 004 KNM	✓	✗	EM90 63X6 022 EDPT 1404	2.213
TK EDPT 14 005 KNM	✓	✗	EM90 80X7 027 EDPT 1404	2.467
TK EDPT 14 006 KNM	✓	✗	EM90 100X8 032 EDPT 1404	2.640
TK EDPT 18 007 KNM	✓	✗	EM90 50X4 022 EDPT 1805	1.958
TK EDPT 18 008 KNM	✓	✗	EM90 63X5 022 EDPT 1805	2.213
TK EDPT 18 009 KNM	✓	✗	EM90 80X6 027 EDPT 1805	2.467

90° LNGU 1104 KNNMTL



KOD	Stok Stock	Inter Cooland	Kesici Uç Uyumluluğu / Insert Suitability	FIYAT PRICE
			KNNMTL LNGU 1104	TL
TK LNGU 11 001 KNM	✓	✓	EM90 40X5 016 LNGU 1104	1.492
TK LNGU 11 003 KNM	✓	✓	EM90 63X6 022 LNGU 1104	1.958
TK LNGU 11 004 KNM	✓	✓	EM90 80X7 027 LNGU 1104	2.213
TK LNGU 11 005 KNM	✓	✓	EM90 50X6 022 LNGU 1104	1.660

90° TNGX 1905 KNNMTL



KOD	Stok Stock	Inter Cooland	Kesici Uç Uyumluluğu / Insert Suitability	FIYAT PRICE
			KNNMTL TNGX 1905	TL
TK TNGX 19 002 KNM	✓	✓	EM90 63X5 022 TNGX 1905	2.382
TK TNGX 19 003 KNM	✓	✓	EM90 80X6 027 TNGX 1905	2.724

90° BDMT 1704 KYCR



KOD	Stok Stock	Inter Cooland	Kesici Uç Uyumluluğu / Insert Suitability	FIYAT PRICE
			KYCR BDMT 1704	TL
TK BDMT 17 001 KYCR	✓	✓	EM90 40X4 022 BDMT 1704	1.176
TK BDMT 17 004 KYCR	✓	✓	EM90 80X6 027 BDMT 1704	1.960

90° LOMU 1004 KYCR



KOD	Stok Stock	Inter Cooland	Kesici Uç Uyumluluğu / Insert Suitability	FIYAT PRICE
			KYCR LOMU 1004	TL
TK LOMU 10 000 KYCR	✓	✓	EM90 40X5 016 LOMU 1004	2.025
TK LOMU 10 001 KYCR	✓	✓	EM90 50X5 022 LOMU 1004	2.381
TK LOMU 10 003 KYCR	✓	✓	EM90 80X8 027 LOMU 1004	3.012
TK LOMU 10 004 KYCR	✓	✓	EM90 50X6 022 LOMU 1004	2.436
TK LOMU 10 005 KYCR	✓	✓	EM90 63X7 022 LOMU 1004	2.696

90° BDMT 11T3 KYCR



KOD	Stok Stock	Inter Cooland	Kesici Uç Uyumluluğu / Insert Suitability	FIYAT PRICE
			KYCR BDMT 11T3	TL
TK BDMT 11 001 KYCR	✓	✓	EM90 40X5 016 BDMT 11T3	1.626
TK BDMT 11 002 KYCR	✓	✓	EM90 50X6 022 BDMT 11T3	1.855

90° WNMU 0504 KYCR



KOD	Stok Stock	Inter Cooland	Kesici Uç Uyumluluğu / Insert Suitability	FİYAT PRICE
			KYCR WNMU 0504	TL
TK WNMU 05 001 KYCR	✓	✓	EM90 40X4 016 WNMU 0504	1.810
TK WNMU 05 002 KYCR	✓	✓	EM90 50X5 022 WNMU 0504	1.994

90° LOMU 1505 KYCR



KOD	Stok Stock	Inter Cooland	Kesici Uç Uyumluluğu / Insert Suitability	FİYAT PRICE
			KYCR LOMU 1505	TL
TK LOMU 15 001 KYCR	✓	✓	EM90 50X4 022 LOMU 1505	1.810
TK LOMU 15 002 KYCR	✓	✓	EM90 63X5 022 LOMU 1505	2.228
TK LOMU 15 006 KYCR	✓	✗	EM90 160X12 040 LOMU 1505	6.328
TK LOMU 15 008 KYCR	✓	✗	EM90 200X14 060 LOMU 1505	10.255

90° WNMU 0806 KYCR



KOD	Stok Stock	Inter Cooland	Kesici Uç Uyumluluğu / Insert Suitability	FİYAT PRICE
			KYCR WNMU 0806	TL
TK WNMU 08 001 KYCR	✓	✓	EM90 50X4 022 WNMU 0806	1.768
TK WNMU 08 002 KYCR	✓	✓	EM90 52X4 022 WNMU 0806	1.817
TK WNMU 08 004 KYCR	✓	✓	EM90 63X5 022 WNMU 0806	2.211
TK WNMU 08 006 KYCR	✓	✓	EM90 80X6 027 WNMU 0806	2.564
TK WNMU 08 007 KYCR	✓	✓	EM90 100X7 032 WNMU 0806	3.096
TK WNMU 08 008 KYCR	✓	✗	EM90 125X8 040 WNMU 0806	3.981
TK WNMU 08 009 KYCR	✓	✗	EM90 160X10 040 WNMU 0806	5.305
TK WNMU 08 011 KYCR	✓	✗	EM90 200X12 060 WNMU 0806	7.519

90° XNGU 15T6 WDA



KOD	Stok Stock	Inter Cooland	Kesici Uç Uyumluluğu / Insert Suitability		FIYAT PRICE
			WDA XNGU 15T6		TL
TK XNGU 15 001 WDA	✓	✓	EM90 40X4 016 XNGU 15T6		1.363
TK XNGU 15 002 WDA	✓	✓	EM90 50X5 022 XNGU 15T6		1.492
TK XNGU 15 003 WDA	✓	✓	EM90 63X5 022 XNGU 15T6		1.660
TK XNGU 15 004 WDA	✓	✓	EM90 80X6 027 XNGU 15T6		2.044
TK XNGU 15 005 WDA	✓	✓	EM90 50X4 022 XNGU 15T6		1.492

90° XDPT 1104/1704 WDA



KOD	Stok Stock	Inter Cooland	Kesici Uç Uyumluluğu / Insert Suitability		FIYAT PRICE
			WDA XDPT 1104/1704		TL
TK XDPT 11 001 WDA	✓	✓	EM90 40X5 016 XDPT 1104		1.575
TK XDPT 11 002 WDA	✓	✓	EM90 50X6 022 XDPT 1104		1.829
TK XDPT 17 002 WDA	✓	✓	EM90 63X6 022 XDPT 1704		2.002

90° BOMT 1304 INGRSL



KOD	Stok Stock	Inter Cooland	Kesici Uç Uyumluluğu / Insert Suitability		FIYAT PRICE
			INGRSL BOMT 1304		TL
TK BOMT 13 001 INGRSL	✓	X	EM90 50X7 022 BOMT 1304		1.660
TK BOMT 13 003 INGRSL	✓	X	EM90 63X8 022 BOMT 1304		1.902
TK BOMT 13 004 INGRSL	✓	X	EM90 80X10 027 BOMT 1304		2.382

90° AOMT 1605 INGRSL



KOD	Stok Stock	Inter Cooland	Kesici Uç Uyumluluğu / Insert Suitability	FIYAT PRICE
			INGRSL AOMT 1605	TL
TK AOMT 16 001 INGRSL	✓	X	EM90 50X4 022 AOMT 1605	1.532
TK AOMT 16 002 INGRSL	✓	X	EM90 63X5 022 AOMT 1605	1.787
TK AOMT 16 003 INGRSL	✓	X	EM90 80X6 027 AOMT 1605	2.213
TK AOMT 16 004 INGRSL	✓	X	EM90 100X8 032 AOMT 1605	2.640

90° XDKT 1505 CRTZT



KOD	Stok Stock	Inter Cooland	Kesici Uç Uyumluluğu / Insert Suitability	FIYAT PRICE
			CRTZ XDKT 1505	TL
TK XDKT 15 001 CRTZT	✓	X	EM90 50X4 022 XDKT 1505	1.449
TK XDKT 15 002 CRTZT	✓	X	EM90 63X5 022 XDKT 1505	1.787

90° AP..1805 DJT



KOD	Stok Stock	Inter Cooland	Kesici Uç Uyumluluğu / Insert Suitability	FIYAT PRICE
			DJT AP.. 18	TL
TK AP.. 18 001 DJT	✓	X	EM90 63X5 022 AP.. 18	2.044
TK AP.. 18 002 DJT	✓	X	EM90 100X8 032 AP..18	2.935

88° SNMX 1206 KRLY



KOD	Stok Stock	Inter Cooland	Kesici Uç Uyumluluğu / Insert Suitability		FİYAT PRICE
			KRLY SNMX 1206		TL
TK SNMX 12 001 KRLY	✓	✓	EM88 50X5 022 SNMX 1206		1.403
TK SNMX 12 002 KRLY	✓	✓	EM88 63X6 022 SNMX 1206		1.548
TK SNMX 12 003 KRLY	✓	✓	EM88 80X8 027 SNMX 1206		2.008
TK SNMX 12 004 KRLY	✓	✓	EM88 100X10 032 SNMX 1206		2.733
TK SNMX 12 005 KRLY	✓	✗	EM88 125X11 040 SNMX 1206		3.530
TK SNMX 12 006 KRLY	✓	✗	EM88 160X12 040 SNMX 1206		4.933
TK SNMX 12 007 KRLY	✓	✗	EM88 160X14 040 SNMX 1206		5.442
TK SNMX 12 009 KRLY	✓	✗	EM88 200X14 060 SNMX 1206		7.350

88° SNCU 1205 ZCC



KOD	Stok Stock	Inter Cooland	Kesici Uç Uyumluluğu / Insert Suitability		FİYAT PRICE
			KYCR SNCU 1205		TL
TK SNCU 12 006 ZCC	✓	✗	EM88 160X12 040 SNCU 1205		5.319

75° APKT 1003/1604 ISO



KOD	Stok Stock	Inter Cooland	Kesici Uç Uyumluluğu / Insert Suitability		FİYAT PRICE
			ISO APKT 1003/1604		TL
TK EM 75 AP 10 007 ISO	✓	✓	EM75 63X6 022 APKT 1003		1.660
TK EM 75 AP 16 001 ISO	✓	✓	EM75 63X4 022 AP.1604		1.532
TK EM 75 AP 16 002 ISO	✓	✓	EM75 80X5 027 AP.1604		1.872
TK EM 75 AP 16 003 ISO	✓	✓	EM75 100X6 032 AP.1604		2.255
TK EM 75 AP 16 004 ISO	✓	✓	EM75 125X7 040 AP.1604		3.360
TK EM 75 AP 16 005 ISO	✓	✓	EM75 160X8 040 AP.1604		5.102

75° SPKN 1203/1504 ISO



75° R390 1806 SNDVK



75° R390 1704 SNDVK



45° OFKT 05T3 ZCC



KOD	Stok Stock	Inter Cooland	Kesici Uç Uyumluluğu / Insert Suitability		FIYAT PRICE
			ISO SPKN 1203		TL
TK SPKN 12 001 ISO	✓	✗	EM75 63X5 022 SPKN 1203		2.213
TK SPKN 12 002 ISO	✓	✗	EM75 80X6 027 SPKN 1203		2.512
TK SPKN 12 003 ISO	✓	✗	EM75 100X8 032 SPKN 1203		3.360
TK SPKN 12 004 ISO	✓	✗	EM75 125X10 040 SPKN 1203		4.212
TK SPKN 12 005 ISO	✓	✗	EM75 160X12 040 SPKN 1203		5.102
TK SPKN 12 006 ISO	✓	✗	EM75 200X12 060 SPKN 1203		6.582
TK SPKN 15 001 ISO	✓	✗	EM75 125X10 040 SPKN 1504		4.212

KOD	Stok Stock	Inter Cooland	Kesici Uç Uyumluluğu / Insert Suitability		FIYAT PRICE
			SNDVK R390 1806		TL
TK 75 R390 18 000 SNDVK	✓	✗	EM75 80X4 027 R390 1806		2.305
TK 75 R390 18 001 SNDVK	✓	✗	EM75 100X5 032 R390 1806		2.512
TK 75 R390 18 002 SNDVK	✓	✗	EM75 125X6 040 R390 1806		3.784

KOD	Stok Stock	Inter Cooland	Kesici Uç Uyumluluğu / Insert Suitability		FIYAT PRICE
			SNDVK R390 1704		TL
TK 75 ADKT 17 004 SNDVK	✓	✗	EM75 63X4 022 R390 1704		1.660
TK 75 ADKT 17 005 SNDVK	✓	✗	EM75 80X5 027 R390 1704		2.002
TK 75 ADKT 17 006 SNDVK	✓	✗	EM75 100X6 032 R390 1704		2.382

KOD	Stok Stock	Inter Cooland	Kesici Uç Uyumluluğu / Insert Suitability		FIYAT PRICE
			ZCC OFKT 05T3		TL
TK OFKT 05 001 ZCC	✓	✓	EM45 50X4 022 OFKT 05T3		1.550
TK OFKT 05 002 ZCC	✓	✓	EM45 63X5 022 OFKT 05T3		1.726
TK OFKT 05 003 ZCC	✓	✓	EM45 80X6 027 OFKT 05T3		2.168
TK OFKT 05 004 ZCC	✓	✓	EM45 100X7 032 OFKT 05T3		3.008

45° ONHU 08T6 ZCC



45° ONHU 060408 ZCC



45° ONHU 0806 ZCC



45° SNEG 1205 ZCC



KOD	Stok Stock	Inter Cooland	Kesici Uç Uyumluluğu / Insert Suitability		FIYAT PRICE
			ZCC ONHU 08T6		TL
TK ONHU 08T 000 ZCC	✓	✓	EM45 50X4 022 ONHU 08T6		1.901
TK ONHU 08T 002 ZCC	✓	✓	EM45 80X6 027 ONHU 08T6		2.652
TK ONHU 08T 003 ZCC	✓	✓	EM45 100X7 032 ONHU 08T6		3.759
TK ONHU 08T 004 ZCC	✓	✗	EM45 125X8 040 ONHU 08T6		4.864
TK ONHU 08T 005 ZCC	✓	✗	EM45 160X10 040 ONHU 08T6		5.749

KOD	Stok Stock	Inter Cooland	Kesici Uç Uyumluluğu / Insert Suitability		FIYAT PRICE
			ZCC ONHU 060408		TL
TK ONHU 06 002 ZCC	✓	✗	EM43 63X5 022 ONHU 060408 ANN		2.256
TK ONHU 06 003 ZCC	✓	✗	EM43 80X7 027 ONHU 060408 ANN		2.652
TK ONHU 06 004 ZCC	✓	✗	EM43 100X8 032 ONHU 060408 ANN		3.627
TK ONHU 06 005 ZCC	✓	✗	EM43 125X9 040 ONHU 060408 ANN		4.864

KOD	Stok Stock	Inter Cooland	Kesici Uç Uyumluluğu / Insert Suitability		FIYAT PRICE
			ZCC ONHU 0806		TL
TK ONHU 08 001 ZCC	✓	✓	EM45 63X5 022 ON..0806		2.256
TK ONHU 08 002 ZCC	✓	✓	EM45 80X6 027 ON..0806		2.652
TK ONHU 08 003 ZCC	✓	✓	EM45 100X7 032 ON..0806		3.627

KOD	Stok Stock	Inter Cooland	Kesici Uç Uyumluluğu / Insert Suitability		FIYAT PRICE
			ZCC SNEG 1205		TL
TK SNEG 12 001 ZCC	✓	✓	EM45 63X6 022 SNEG 1205		1.857
TK SNEG 12 002 ZCC	✓	✓	EM45 80X7 027 SNEG 1205		2.363
TK SNEG 12 003 ZCC	✓	✗	EM45 125X10 040 SNEG 1205		4.204
TK SNEG 12 005 ZCC	✓	✓	EM45 50X5 022 SNEG 1205		1.726
TK SNEG 12 006 ZCC	✓	✓	EM45 100X8 032 SNEG 1205		2.522

45° SE..12T3/SE 15..ZCC/SNDVK



KOD	Stok Stock	Inter Cooland	Kesici Uç Uyumluluğu / Insert Suitability	FIYAT PRICE
			ZCC - SNDVK SEET 12T3/SE 15..	TL
TK SE.. 12 001 ZCC	✓	✓	EM45 50X4 022 SE..12T3	1.326
TK SE.. 12 002 ZCC	✓	✓	EM45 63X5 022 SE..12T3	1.726
TK SE.. 12 003 ZCC	✓	✓	EM45 80X6 027 SE..12T3	2.035
TK SE.. 12 004 ZCC	✓	✓	EM45 100X7 032 SE..12T3	2.433
TK SE.. 12 005 ZCC	✓	✗	EM45 125X8 040 SE..12T3	3.248
TK SE.. 12 007 ZCC	✓	✗	EM45 160X10 040 SE..12T3	5.305

45° OFMT 0706 ISO



KOD	Stok Stock	Inter Cooland	Kesici Uç Uyumluluğu / Insert Suitability	FIYAT PRICE
			ISO OFMT 0706	TL
TK OFMT 07 001 ISO	✓	✓	EM45 63X5 022 OFMT 0706	2.255
TK OFMT 07 002 ISO	✓	✓	EM45 80X6 027 OFMT 0706	2.512
TK OFMT 07 003 ISO	✓	✓	EM45 100X7 032 OFMT 0706	3.488
TK OFMT 07 004 ISO	✓	✗	EM45 125X8 040 OFMT 0706	4.212

45° ONGX 0606 ISO



KOD	Stok Stock	Inter Cooland	Kesici Uç Uyumluluğu / Insert Suitability	FIYAT PRICE
			ISO ONGX 0606	TL
TK ONGX 06 001 ISO	✓	✓	EM45 63X5 022 ONGX 0606	2.044
TK ONGX 06 002 ISO	✓	✓	EM45 80X6 027 ONGX 0606	2.340
TK ONGX 06 003 ISO	✓	✓	EM45 100X8 032 ONGX 0606	2.978
TK ONGX 06 005 ISO	✓	✗	EM45 160X10 040 ONGX 0606	5.102

45° ONMU 0504 ISO



KOD	Stok Stock	Inter Cooland	Kesici Uç Uyumluluğu / Insert Suitability	FIYAT PRICE
			ISO ONMU 0504	TL
TK ONMU 05 001 ISO	✓	✓	EM45 50X5 022 ONMU 0504	1.660
TK ONMU 05 002 ISO	✓	✓	EM45 63X6 022 ONMU 0504	2.044
TK ONMU 05 003 ISO	✓	✓	EM45 80X7 027 ONMU 0504	2.382
TK ONMU 05 004 ISO	✓	✓	EM45 100X8 032 ONMU 0504	3.104
TK ONMU 05 005 ISO	✓	✗	EM45 125X9 040 ONMU 0504	4.212

45° PNCU 0805 ISO



KOD	Stok Stock	Inter Cooland	Kesici Uç Uyumluluğu / Insert Suitability		FIYAT PRICE
			INGRSL PNCU 0805		TL
TK PNCU 08 003 INGRSL	✓	✓	EM45 50X5 022 PNCU 0805		1.618
TK PNCU 08 004 INGRSL	✓	✓	EM45 80X6 027 PNCU 0805		2.380
TK PNCU 08 005 INGRSL	✓	✓	EM45 63X5 022 PNCU 0805		1.933

45° SEKR 1204 ISO



KOD	Stok Stock	Inter Cooland	Kesici Uç Uyumluluğu / Insert Suitability		FIYAT PRICE
			ISO SEKR 1204		TL
TK SEKR 12 001 ISO	✓	✓	EM45 63X5 022 SEKR 1204		1.829
TK SEKR 12 002 ISO	✓	✓	EM45 100X8 032 SEKR 1204		2.640

45° SN.. 1206 KRLY



KOD	Stok Stock	Inter Cooland	Kesici Uç Uyumluluğu / Insert Suitability		FIYAT PRICE
			KRLY SN..1206		TL
TK SN.. 12 001 KRLY	✓	✓	EM45 50X5 022 SN..1206		1.644
TK SN.. 12 002 KRLY	✓	✓	EM45 63X6 022 SN..1206		1.959
TK SN.. 12 003 KRLY	✓	✓	EM45 80X8 027 SN..1206		2.273
TK SN.. 12 004 KRLY	✓	✓	EM45 100X10 032 SN..1206		2.515
TK SN.. 12 005 KRLY	✓	X	EM45 125X11 040 SN..1206		4.208
TK SN.. 12 006 KRLY	✓	X	EM45 160X12 040 SN..1206		5.102

45° SNMX 1407 SECO



KOD	Stok Stock	Inter Cooland	Kesici Uç Uyumluluğu / Insert Suitability		FIYAT PRICE
			SECO SNMX 1407		TL
TK SNMX 14 004 SECO	✓	X	EM45 100X7 032 SNMX 1407		3.657
TK SNMX 14 005 SECO	✓	X	EM45 125X8 040 SNMX 1407		4.678

45° SNHG 1205 VNDRT



KOD	Stok Stock	Inter Cooland	Kesici Uç Uyumluluğu / Insert Suitability	FIYAT PRICE
			VNDRT SNHG 1205	TL
TK SNHG 12 001 VNDRT	✓	✓	EM45 50X6 022 SNHG 1205	1.492
TK SNHG 12 002 VNDRT	✓	✓	EM45 63X6 022 SNHG 1205	1.829
TK SNHG 12 003 VNDRT	✓	✓	EM45 80X7 027 SNHG 1205	2.213
TK SNHG 12 004 VNDRT	✓	✓	EM45 100X8 032 SNHG 1205	2.640

45° SNGU 1408 MTSBSh



KOD	Stok Stock	Inter Cooland	Kesici Uç Uyumluluğu / Insert Suitability	FIYAT PRICE
			MTSBSh SNGU 1408	TL
TK SNGU 14 001 MTSBSh	✓	✓	EM45 63X5 022 SNGU 1408	1.742
TK SNGU 14 002 MTSBSh	✓	✓	EM45 80X7 027 SNGU 1408	2.297
TK SNGU 14 003 MTSBSh	✓	✓	EM45 100X8 032 SNGU 1408	2.782

45° SNMX 1306 TT



KOD	Stok Stock	Inter Cooland	Kesici Uç Uyumluluğu / Insert Suitability	FIYAT PRICE
			TT SNMX 1306	TL
TK SNMX 13 001 TT	X	✓	EM88 63X6 027 SNMX 1306 TT	1.488
TK SNMX 13 002 TT	X	✓	EM88 80X8 027 SNMX 1306 TT	1.837
TK SNMX 13 003 TT	X	✓	EM88 100X10 032 SNMX 1306 TT	2.782

45° SNMU 13T6 SMTM



KOD	Stok Stock	Inter Cooland	Kesici Uç Uyumluluğu / Insert Suitability	FIYAT PRICE
			SMTM SNMU 13T6	TL
TK SNMU 13T 001 SMTM	✓	✓	EM45 63X6 022 SNMU 13T6	2.048
TK SNMU 13T 002 SMTM	✓	✓	EM45 80X7 027 SNMU 13T6	2.454
TK SNMU 13T 003 SMTM	✓	✓	EM45 100X8 032 SNMU 13T6	3.007

45° SN.. 1305 I



KOD	Stok Stock	Inter Cooland	Kesici Uç Uyumluluğu / Insert Suitability		FIYAT PRICE
			I SN..1305		TL
TK SN..13 001 I	✓	✓	EM45 50X4 022 SN..1305		1.787
TK SN..13 002 I	✓	✓	EM45 63X6 022 SN..1305		2.213
TK SN..13 003 I	✓	✓	EM45 80X7 027 SN..1305		2.512
TK SN..13 004 I	✓	✓	EM45 100X8 032 SN..1305		2.978
TK SN..13 005 I	✓	x	EM45 125X9 040 SN..1305		3.784

45° PNMU 0905/1205 KYCR



KOD	Stok Stock	Inter Cooland	Kesici Uç Uyumluluğu / Insert Suitability		FIYAT PRICE
			KYCR PNMU 0905/1205		TL
TK PNMU 12 002 KYCR	✓	✓	EM45 50X4 022 PNMU 1205		1.682
TK PNMU 12 003 KYCR	✓	✓	EM45 63X5 022 PNMU 1205		1.901
TK PNMU 12 004 KYCR	✓	✓	EM45 80X5 027 PNMU 1205		2.301
TK PNMU 12 005 KYCR	✓	✓	EM45 100X8 032 PNMU 1205		3.759
TK PNMU 12 006 KYCR	✓	x	EM45 125X10 040 PNMU 1205		4.335
TK PNMU 12 007 KYCR	✓	x	EM45 160X12 040 PNMU 1205		5.305
TK PNMU 12 009 KYCR	✓	x	EM45 250X14 060 PNMU 1205		10.171

45° PNMU 0905 SNG



KOD	Stok Stock	Inter Cooland	Kesici Uç Uyumluluğu / Insert Suitability		FIYAT PRICE
			SNG PNMU 0905		TL
TK PNMU 09 001 SNG	✓	✓	EM45 50X4 022 PNMU 0905		1.682
TK PNMU 09 003 SNG	✓	✓	EM45 80X6 027 PNMU 0905		2.522
TK PNMU 09 004 SNG	✓	✓	EM45 100X7 032 PNMU 0905		2.875
TK PNMU 09 005 SNG	✓	✓	EM45 125X10 040 PNMU 0905		4.335

45° HN..0604 KNNMTL



KOD	Stok Stock	Inter Cooland	Kesici Uç Uyumluluğu / Insert Suitability		FIYAT PRICE
			KNNMTL HN..0604		TL
TK HN.. 06 002 KNM	✓	✓	EM45 63X6 022 HN..0604		2.085
TK HN.. 06 003 KNM	✓	✓	EM45 80X6 027 HN..0604		2.512
TK HN.. 06 004 KNM	✓	✓	EM45 100X8 032 HN..0604		2.724

45° HNGJ 0905 WDA/KNNMTL



45° HNPJ 0704 WDA



45° HN.. 0906 PRMT



44° ONMU 0505 I



KOD	Stok Stock	Inter Cooland	Kesici Uç Uyumluluğu / Insert Suitability		FİYAT PRICE
			WDA-KNNMTL HNGJ 0905		TL
TK HN.. 09 001 KN WD	✓	✓	EM45 50X4 022 HN..0905		1.917
TK HN.. 09 002 KN WD	✓	✓	EM45 63X4 022 HN..0905		2.085
TK HN.. 09 004 KN WD	✓	✓	EM45 80X6 027 HN..0905		2.297
TK HN.. 09 005 KN WD	✓	✓	EM45 100X8 032 HN..0905		3.482
TK HN.. 09 006 KN WD	✓	✗	EM45 125X10 040 HN..0905		4.522
TK HN.. 09 007 KN WD	✓	✗	EM45 160X12 040 HN..0905		5.529
TK HN.. 09 010 KNM WD	✓	✗	EM45 250X14 060 HN..0905		9.357

KOD	Stok Stock	Inter Cooland	Kesici Uç Uyumluluğu / Insert Suitability		FİYAT PRICE
			WDA HNPJ 0704		TL
TK HNPJ 07 001 WDA	✓	✓	EM45 50X4 022 HNPJ 0704		1.885
TK HNPJ 07 002 WDA	✓	✓	EM45 63X5 022 HNPJ 0704		2.030
TK HNPJ 07 004 WDA	✓	✓	EM45 80X6 027 HNPJ 0704		2.322
TK HNPJ 07 006 WDA	✓	✓	EM45 100X7 032 HNPJ 0704		3.410
TK HNPJ 07 007 WDA	✓	✗	EM45 125X8 040 HNPJ 0704		4.522
TK HNPJ 07 008 WDA	✓	✗	EM45 160X10 040 HNPJ 0704		5.417
TK HNPJ 07 009 WDA	✓	✓	EM45 50X5 022 HNPJ 0704		1.983

KOD	Stok Stock	Inter Cooland	Kesici Uç Uyumluluğu / Insert Suitability		FİYAT PRICE
			PRMT HN.. 0906		TL
TK HN.. 09 001 PRMT	✓	✓	EM45 50X4 022 HN..0906		1.917
TK HN.. 09 003 PRMT	✓	✓	EM45 80X6 027 HN..0906		2.297
TK HN.. 09 004 PRMT	✓	✓	EM45 100X8 032 HN..0906		3.482
TK HN.. 09 005 PRMT	✓	✓	EM45 125X10 040 HN..0906		4.522
TK HN.. 09 006 PRMT	✓	✗	EM45 160X12 040 HN..0906		5.513
TK HN.. 09 007 PRMT	✓	✗	EM45 200X12 060 HN..0906		7.230
TK HN.. 09 008 PRMT	✓	✗	EM45 250X12 060 HN..0906		9.357
TK HN.. 09 010 PRMT	✓	✗	EM45 300X16 060 HN..0906		13.975
TK HN.. 09 011 PRMT	✓	✓	EM45 63X5 022 HN..0906		2.079

KOD	Stok Stock	Inter Cooland	Kesici Uç Uyumluluğu / Insert Suitability		FİYAT PRICE
			I ONMU 0505		TL
TK ON..05 001 I	✓	✓	EM44 40X3 016 ON..0505		1.449
TK ON..05 002 I	✓	✓	EM44 50X4 022 ON..0505		1.787
TK ON..05 003 I	✓	✓	EM44 63X6 022 ON..0505		2.213
TK ON..05 004 I	✓	✓	EM44 80X7 027 ON..0505		2.512
TK ON..05 005 I	✓	✓	EM44 100X8 032 ON..0505		2.978
TK ON..05 006 I	✓	✗	EM44 125X9 040 ON..0505		3.784

44° ONMX 1205 VNDRT



KOD	Stok Stock	Inter Cooland	Kesici Uç Uyumluluğu / Insert Suitability	FİYAT PRICE
			VNDRT ONMX 1205	TL
TK ONMX 12 001 VNDRT	✓	✓	EM44 50X5 022 ONMX 1205	1.829
TK ONMX 12 002 VNDRT	✓	✓	EM44 63X6 022 ONMX 1205	2.044
TK ONMX 12 003 VNDRT	✓	✓	EM44 80X7 027 ONMX 1205	2.467

40° NNMU 2007 MTSBSH



KOD	Stok Stock	Inter Cooland	Kesici Uç Uyumluluğu / Insert Suitability	FİYAT PRICE
			MTSBSH NNMU 2007	TL
TK NNMU 20 001 MTSBSH	✓	✓	EM40 63X5 022 NNMU 2007	2.297
TK NNMU 20 002 MTSBSH	✓	✓	EM40 80X6 027 NNMU 2007	2.680
TK NNMU 20 003 MTSBSH	✓	✓	EM40 100X7 032 NNMU 2007	3.104
TK NNMU 20 004 MTSBSH	✓	✗	EM40 125X8 040 NNMU 2007	4.000
TK NNMU 20 005 MTSBSH	✓	✗	EM40 160X10 040 NNMU 2007	5.102
TK NNMU 20 006 MTSBSH	✓	✗	EM40 200X12 060 NNMU 2007	9.357

67° PNEG 1105 ZCC



KOD	Stok Stock	Inter Cooland	Kesici Uç Uyumluluğu / Insert Suitability	FİYAT PRICE
			ZCC PNEG 1105	TL
TK PNEG 11 001 ZCC	✓	✓	EM67 50X5 022 PNEG 1105	1.857
TK PNEG 11 002 ZCC	✓	✓	EM67 63X6 022 PNEG 1105	2.035
TK PNEG 11 003 ZCC	✓	✓	EM67 80X8 027 PNEG 1105	2.433
TK PNEG 11 004 ZCC	✓	✓	EM67 100X10 032 PNEG 1105	3.185
TK PNEG 11 005 ZCC	✓	✗	EM67 125X12 040 PNEG 1105	4.292
TK PNEG 11 006 ZCC	✓	✗	EM67 160X14 040 PNEG 1105	5.305

SDMT 09T3 ZCC



KOD	Stok Stock	Inter Cooland	Kesici Uç Uyumluluğu / Insert Suitability	FIYAT PRICE
			ZCC SDMT 09T312	TL
TK SDMT 09 001 ZCC	✓	✓	BMR 40X4 016 SDMT 09T312	1.508
TK SDMT 09 002 ZCC	✓	✓	BMR 50X4 022 SDMT 09T312	1.784
TK SDMT 09 004 ZCC	✓	✓	BMR 50X5 022 SDMT 09T312	1.821
TK SDMT 09 005 ZCC	✓	✓	BMR 52X5 022 SDMT 09T312	1.821
TK SDMT 09 006 ZCC	✓	✓	BMR 52X6 022 SDMT 09T312	1.909
TK SDMT 09 007 ZCC	✓	✓	BMR 60X6 022 SDMT 09T312	2.072
TK SDMT 09 008 ZCC	✓	✓	BMR 63X6 022 SDMT 09T312	2.072
TK SDMT 09 009 ZCC	✓	✓	BMR 80X7 027 SDMT 09T3	2.337
TK SDMT 09 010 ZCC	✓	✓	BMR 100X8 032 SDMT 09T3	2.876

SDMT 1204 ZCC



KOD	Stok Stock	Inter Cooland	Kesici Uç Uyumluluğu / Insert Suitability	FIYAT PRICE
			ZCC SDMT 1204	TL
TK SDMT 12 001 ZCC	✓	✓	BMR 50X5 022 SDMT 1204 ZCC	1.709
TK SDMT 12 002 ZCC	✓	✓	BMR 52X4 022 SDMT 1204 ZCC	1.734
TK SDMT 12 003 ZCC	✓	✓	BMR 66X5 022 SDMT 1204 ZCC	2.137
TK SDMT 12 004 ZCC	✓	✓	BMR 66X5 027 SDMT 1204 ZCC	2.137
TK SDMT 12 005 ZCC	✓	✓	BMR 80X6 027 SDMT 1204 ZCC	2.238
TK SDMT 12 006 ZCC	✓	✓	BMR 50X4 022 SDMT 1204 ZCC	1.683
TK SDMT 12 007 ZCC	✓	✓	BMR 63X5 022 SDMT 1204 ZCC	2.061
TK SDMT 12 008 ZCC	✓	✓	BMR 100X8 032 SDMT 1204 ZCC	2.589

SDMT 1204 ISO



KOD	Stok Stock	Inter Cooland	Kesici Uç Uyumluluğu / Insert Suitability	FIYAT PRICE
			ISO SDMT 1204	TL
TK SDMT 12 001 ISO	✓	✓	BMR 52X4 022 SDMT 1204	1.752
TK SDMT 12 002 ISO	✓	✓	BMR 66X5 022 SDMT 1204	2.008
TK SDMT 12 003 ISO	✓	✓	BMR 80X6 027 SDMT 1204	2.512

ZCDW 09T3 ZDEW 1204 PRMT



KOD	Stok Stock	Inter Cooland	Kesici Uç Uyumluluğu / Insert Suitability	FIYAT PRICE
			PRMT ZDCW 09T3- ZDEW 1204	TL
TK ZDCW 09 001 PRMT	✓	✓	BMR 40X4 016 ZDCW 09T304	1.790
TK ZDCW 12 002 PRMT	✓	✓	BMR 50X4 022 ZDEW 12408	2.104
TK ZDCW 12 003 PRMT	✓	✓	BMR 63X5 022 ZDEW 12408	2.640

SDMT 1004 BHLR



KOD	Stok Stock	Inter Cooland	Kesici Uç Uyumluluğu / Insert Suitability	FIYAT PRICE
			BHLR SDMT 1004	TL
TK SDMT 10 002 BHLR	✓	✓	BMR 50X5 022 SDMT 1004	1.700
TK SDMT 10 003 BHLR	✓	✓	BMR 40X4 016 SDMT 1004	1.597

SDMT 1206 ING



KOD	Stok Stock	Inter Cooland	Kesici Uç Uyumluluğu / Insert Suitability	FIYAT PRICE
			ING SDMT 1206	TL
TK SDMT 12 002 ING	✗	✓	BMR 63X5 022 SDMT 1206 ING	1.917
TK SDMT 12 003 ING	✗	✓	BMR 80X6 027 SDMT 1206 ING	3.063

SOEW 13M510 PLBT



KOD	Stok Stock	Inter Cooland	Kesici Uç Uyumluluğu / Insert Suitability	FIYAT PRICE
			PLBT SOEW 13M510	TL
TK SOEW 13 001 PLBT	✓	✓	BMR 52X4 022 SOEW 13	1.618
TK SOEW 13 002 PLBT	✓	✓	BMR 63X5 022 SOEW 13	2.002

SDMX 09T3 PLBT



KOD	Stok Stock	Inter Cooland	Kesici Uç Uyumluluğu / Insert Suitability	FIYAT PRICE
			PLBT SDMX 09T3	TL
TK SDMX 09 001 PLBT	✓	✓	BMR 42X6 016 SDMX 09T3	1.618
TK SDMX 09 002 PLBT	✓	✓	BMR 52X7 022 SDMX 09T3	1.958
TK SDMX 09 004 PLBT	✓	✓	BMR 50X6 022 SDMX 09T3	1.958

SOMT 1004/1405 KYCR



KOD	Stok Stock	Inter Cooland	Kesici Uç Uyumluluğu / Insert Suitability	FIYAT PRICE
			KYCR SOMT 1004-1405	TL
TK SOMT 10 001 KYCR	✓	✓	BMR 50X5 022 SOMT 1004	1.817
TK SOMT 10 002 KYCR	✓	✓	BMR 52X5 022 SOMT 1004	1.817
TK SOMT 14 004 KYCR	✓	✓	BMR 52X4 022 SOMT 1405	1.835
TK SOMT 14 005 KYCR	✓	✓	BMR 63X5 022 SOMT 1405	2.037
TK SOMT 14 006 KYCR	✓	✓	BMR 80X6 027 SOMT 1405	2.489
TK SOMT 14 008 KYCR	✓	✓	BMR 66X5 027 SOMT 1405	2.263

LOGU 0303 KYCR



KOD	Stok Stock	Inter Cooland	Kesici Uç Uyumluluğu / Insert Suitability	FIYAT PRICE
			KYCR LOGU 030310	TL
TK LOGU 03 001 KYCR	✓	✓	BMR 40X6 016 LOGU 030310	2.168
TK LOGU 03 002 KYCR	✓	✓	BMR 50X7 022 LOGU 030310	2.206
TK LOGU 03 004 KYCR	✓	✓	BMR 52X6 022 LOGU 030310	2.295
TK LOGU 03 005 KYCR	✓	✓	BMR 50X6 022 LOGU 030310	2.206

SPMW 1204 SNG



KOD	Stok Stock	Inter Cooland	Kesici Uç Uyumluluğu / Insert Suitability	FIYAT PRICE
			SNG SPMW 1204	TL
TK SPMW 12 001 SNG	✓	✓	BMR 50X5 022 SPMW 1204	1.857
TK SPMW 12 002 SNG	✓	✓	BMR 80X5 027 SPMW 1204	2.433
TK SPMW 12 003 SNG	✓	✓	BMR 80X8 027 SPMW 1204	2.522
TK SPMW 12 004 SNG	✓	✓	BMR 100X8 032 SPMW 1204	2.787
TK SPMW 12 008 SNG	✓	✓	BMR 63X5 022 SPMW 1204	2.125
TK SPMW 12 009 SNG	✓	✓	BMR 52X5 022 SPMW 1204	2.009

SOMW 080315 SNG



KOD	Stok Stock	Inter Cooland	Kesici Uç Uyumluluğu / Insert Suitability	FIYAT PRICE
			SNG SOMW 080315	TL
TK SOMW 08 001 SNG	✓	✓	BMR 40X5 016 SOMW 080315	1.638
TK SOMW 08 002 SNG	✓	✓	BMR 50X6 022 SOMW 080315	1.726
TK SOMW 08 003 SNG	✓	✓	BMR 63X7 022 SOMW 080315	2.035

WNMX 09T3/1305 KRLY

KOD	Stok Stock	Inter Cooland	Kesici Uç Uyumluluğu / Insert Suitability		FİYAT PRICE
			KRLY WNMX 09T3 / 1305		TL
TK WNMX 09 002 KRLY	✓	✓	BMR 40X4 016 WNMX 09T316		1.575
TK WNMX 09 003 KRLY	✓	✓	BMR 50X4 022 WNMX 09T316		1.787
TK WNMX 09 004 KRLY	✓	✓	BMR 52X4 022 WNMX 09T316		1.787
TK WNMX 09 005 KRLY	✓	✓	BMR 52X5 022 WNMX 09T316		1.872
TK WNMX 09 006 KRLY	✓	✓	BMR 52X6 022 WNMX 09T316		1.872
TK WNMX 09 007 KRLY	✓	✓	BMR 63X5 022 WNMX 09T316		2.297
TK WNMX 09 008 KRLY	✓	✓	BMR 66X6 022 WNMX 09T316		2.297
TK WNMX 09 009 KRLY	✓	✓	BMR 66X6 027 WNMX 09T316		2.297
TK WNMX 09 010 KRLY	✓	✓	BMR 80X7 027 WNMX 09T316		2.550
TK WNMX 13 011 KRLY	✓	✓	BMR 63X4 022 WNMX 130520		2.177
TK WNMX 13 012 KRLY	✓	✓	BMR 80X5 027 WNMX 130520		2.382
TK WNMX 13 013 KRLY	✓	✓	BMR 52X4 022 WNMX 130520		1.663

LNMT 060310R KRLY

KOD	Stok Stock	Inter Cooland	Kesici Uç Uyumluluğu / Insert Suitability		FİYAT PRICE
			KRLY LNMT 060310R		TL
TK LNMT 06 001 KRLY	✓	✓	BMR 40X6 016 LNMT 060310R		1.787
TK LNMT 06 002 KRLY	✓	✓	BMR 52X8 022 LNMT 060310R		2.085
TK LNMT 06 003 KRLY	✓	✓	BMR 63X9 022 LNMT 060310R		2.340
TK LNMT 06 004 KRLY	✓	✓	BMR 66X9 027 LNMT 060310R		2.340

LNMX 060310R KRLY

KOD	Stok Stock	Inter Cooland	Kesici Uç Uyumluluğu / Insert Suitability		FİYAT PRICE
			KRLY LNMX 060310		TL
TK LNMX 06 001 KRLY	✓	✓	BMR 40X6 016 LNMX 060310		1.787
TK LNMX 06 002 KRLY	✓	✓	BMR 52X7 022 LNMX 060310		2.085
TK LNMX 06 003 KRLY	✓	✓	BMR 52X8 022 LNMX 060310		2.213
TK LNMX 06 005 KRLY	✓	✓	BMR 50x7 022 LNMX 060310		2.085
TK LNMX 06 006 KRLY	✓	✓	BMR 63x8 022 LNMX 060310		2.425
TK LNMX 06 007 KRLY	✓	✓	BMR 80x10 027 LNMX 060310		2.809

BLM 0603 TT



KOD	Stok Stock	Inter Cooland	Kesici Uç Uyumluluğu / Insert Suitability	FIYAT PRICE
			TT BLM 0603	TL
TK BLM 06 001 TT	✓	✓	BMR 40X6 016 BLM 0603	1.618
TK BLM 06 002 TT	✓	✓	BMR 50X7 022 BLM 0603	1.872
TK BLM 06 003 TT	✓	✓	BMR 63X8 022 BLM 0603	2.104

LNMU 0303 TNGLY



KOD	Stok Stock	Inter Cooland	Kesici Uç Uyumluluğu / Insert Suitability	FIYAT PRICE
			TNGLY LNLMU 0303	TL
TK LNLMU 03 001 TNG	✓	✓	BMR 40X6 016 LNLMU 0303	1.909
TK LNLMU 03 002 TNG	✓	✓	BMR 50X7 022 LNLMU 0303	2.242
TK LNLMU 03 003 TNG	✓	✓	BMR 63X8 022 LNLMU 0303	2.533
TK LNLMU 03 004 TNG	✓	✓	BMR 52X7 022 LNLMU 0303	2.242

XDPT 0904 WDA



KOD	Stok Stock	Inter Cooland	Kesici Uç Uyumluluğu / Insert Suitability	FIYAT PRICE
			WDA XDPT 0904	TL
TK XDPT 09 001 WDA	✓	✓	BMR 40X5 016 XDPT 0904	1.660
TK XDPT 09 002 WDA	✓	✓	BMR 50X5 022 XDPT 0904	1.958
TK XDPT 09 003 WDA	✓	✓	BMR 50X6 022 XDPT 0904	2.085
TK XDPT 09 004 WDA	✓	✓	BMR 52X6 022 XDPT 0904	2.085

P26335 WLTR



KOD	Stok Stock	Inter Cooland	Kesici Uç Uyumluluğu / Insert Suitability	FIYAT PRICE
			WLTR P26335R-10-14	TL
TK P26335 001 WLTR	✓	✓	BMR 50X5 022 P26335R-14	1.787
TK P26335 002 WLTR	✓	✓	BMR 52X5 022 P26335R-14	1.787
TK P26335 003 WLTR	✓	✓	BMR 63X6 022 P26335R-14	2.085
TK P26335 004 WLTR	✗	✓	BMR 52X3 022 P26335R-25	1.660

UNEU 1307R INGRSL



KOD	Stok Stock	Inter Cooland	Kesici Uç Uyumluluğu / Insert Suitability	FIYAT PRICE
			INGRSL UNEU 1307R	TL
TK UNEU 13 001 INGRSL	✓	✓	BMR 52X3 022 UNEU 1307R	1.660
TK UNEU 13 002 INGRSL	✓	✓	BMR 63X4 022 UNEU 1307R	1.958

RPMT 10T3 KYCR



KOD	Stok Stock	Inter Cooland	Kesici Uç Uyumluluğu / Insert Suitability	FIYAT PRICE
			KYCR RPMT 10T3	TL
TK RPMT 10 002 KYCR	✓	✓	EMR 40X5 016 RPMT 10T3	1.326
TK RPMT 10 003 KYCR	✓	✓	EMR 50X6 022 RPMT 10T3	1.592

RPMT 1204 KYCR



KOD	Stok Stock	Inter Cooland	Kesici Uç Uyumluluğu / Insert Suitability		FIYAT PRICE
			KYCR RPMT 1204		TL
TK RPMT 12 001 KYCR	✓	✓	EMR 40X4 016 RPMT 1204		1.281
TK RPMT 12 003 KYCR	✓	✓	EMR 52X5 022 RPMT 1204		1.592
TK RPMT 12 004 KYCR	✓	✓	EMR 63X6 022 RPMT 1204		1.901
TK RPMT 12 006 KYCR	✗	✓	EMR 66X6 027 RPMT 1204		1.992

RDKW 1003/12T3/1204 1604/2006 ISO



KOD	Stok Stock	Inter Cooland	Kesici Uç Uyumluluğu / Insert Suitability		FIYAT PRICE
			ISO RDKW 1003/12T3/1204/1604/2006		TL
TK RD..10 001 ISO	✓	✓	EMR 40X4 016 RDKW 1003		1.153
TK RD..10 002 ISO	✓	✓	EMR 50X5 022 RDKW 1003		1.363
TK RD..10 003 ISO	✓	✓	EMR 63X6 022 RDKW 1003		1.787
TK RD..10 004 ISO	✓	✓	EMR 80X7 027 RDKW 1003		2.085
TK RD..10 005 ISO	✓	✓	EMR 100X8 032 RDKW 1003		2.297
TK RD..12 006 ISO	✓	✓	EMR 40X4 016 RDKW 12T3		1.153
TK RD..12 007 ISO	✓	✓	EMR 50X5 022 RDKW 12T3		1.363
TK RD..12 008 ISO	✓	✓	EMR 52X5 022 RDKW 12T3		1.403
TK RD..12 009 ISO	✓	✓	EMR 63X6 022 RDKW 12T3		1.787
TK RD..12 010 ISO	✓	✓	EMR 80X7 027 RDKW 12T3		2.085
TK RD..12 011 ISO	✓	✓	EMR 100X8 032 RDKW 12T3		2.297
TK RD..12 012 ISO	✓	✓	EMR 40X4 016 RDKW 1204		1.153
TK RD..12 013 ISO	✓	✓	EMR 50X5 022 RDKW 1204		1.363
TK RD..12 014 ISO	✓	✓	EMR 63X6 022 RDKW 1204		1.787
TK RD..12 015 ISO	✓	✓	EMR 80X7 027 RDKW 1204		2.085
TK RD..12 016 ISO	✓	✓	EMR 100X8 032 RDKW 1204		2.297
TK RD..12 017 ISO	✓	✗	EMR 125X9 040 RDKW 1204		3.624
TK RD..12 027 ISO	✓	✗	EMR 125X9 040 RDKW 12T3		3.543
TK RD..12 028 ISO	✓	✗	EMR 160X10 040 RDKW 12T3		4.595
TK RD..16 016 ISO	✓	✓	EMR 50X4 022 RDKW 1604		1.363
TK RD..16 017 ISO	✓	✓	EMR 52X4 022 RDKW 1604		1.363
TK RD..16 018 ISO	✓	✓	EMR 63X4 022 RDKW 1604		1.787
TK RD..16 019 ISO	✓	✓	EMR 66X5 027 RDKW 1604		1.787
TK RD..16 020 ISO	✓	✓	EMR 80X5 027 RDKW 1604		2.085
TK RD..16 021 ISO	✓	✓	EMR 100X6 032 RDKW 1604		2.297
TK RD..16 022 ISO	✓	✗	EMR 125X7 040 RDKW 1604		3.543
TK RD..16 023 ISO	✓	✗	EMR 160X8 040 RDKW 1604		3.829

RDKW 10T3 ISO



KOD	Stok Stock	Inter Cooland	Kesici Uç Uyumluluğu / Insert Suitability	FIYAT PRICE
			ISO RDKW 10T3	TL
TK RDKW 10 001 ISO	✓	✓	EMR 50X5 022 RDKW 10T3	1.363
TK RDKW 10 002 ISO	✓	✓	EMR 63X6 022 RDKW 10T3	1.787
TK RDKW 10 003 ISO	✓	✓	EMR 80X7 027 RDKW 10T3	2.085

RPMT 1204 ISO



KOD	Stok Stock	Inter Cooland	Kesici Uç Uyumluluğu / Insert Suitability	FIYAT PRICE
			ISO RPMT 1204	TL
TK RPMT 12 001 ISO	✓	✓	EMR 40X4 016 RPMT 1204	1.233
TK RPMT 12 002 ISO	✓	✓	EMR 50X5 022 RPMT 1204	1.532
TK RPMT 12 003 ISO	✓	✓	EMR 52X5 022 RPMT 1204	1.532
TK RPMT 12 004 ISO	✓	✓	EMR 63X6 027 RPMT 1204	1.787
TK RPMT 12 005 ISO	✓	✓	EMR 80X7 027 RPMT 1204	2.170
TK RP. 12 002 ZCC	✓	✓	EMR 50X5 022 RP. 1204	1.592

RPMW 1003 ISO



KOD	Stok Stock	Inter Cooland	Kesici Uç Uyumluluğu / Insert Suitability	FIYAT PRICE
			ISO RPMW 1003	TL
TK RPMW 10 001 ISO	✓	✓	EMR 40X4 016 RPMW 1003	1.233
TK RPMW 10 002 ISO	✓	✓	EMR 50X5 022 RPMW 1003	1.449
TK RPMW 10 003 ISO	✓	✓	EMR 63X6 022 RPMW 1003	1.618
TK RPMW 10 004 ISO	✓	✓	EMR 80X7 027 RPMW 1003	2.127

RPMT 1204 TNGLY



KOD	Stok Stock	Inter Cooland	Kesici Uç Uyumluluğu / Insert Suitability	FIYAT PRICE
			TNGLY RPMT 1204	TL
TK RPMT 12 001 TNG	✓	✓	EMR 40X4 016 RPMT 1204	1.403
TK RPMT 12 002 TNG	✓	✓	EMR 50X5 022 RPMT 1204	1.575
TK RPMT 12 003 TNG	✓	✓	EMR 63X6 022 RPMT 1204	1.787

RPMT 10T3 TNGLY



KOD	Stok Stock	Inter Cooland	Kesici Uç Uyumluluğu / Insert Suitability	FIYAT PRICE
			TNGLY RPMT 10T3	TL
TK RPMT 10T 001 TNG	✓	✓	EMR 40X4 016 RPMT 10T3	1.403
TK RPMT 10T 002 TNG	✓	✓	EMR 50X5 022 RPMT 10T3	1.575
TK RPMT 10T 003 TNG	✓	✓	EMR 63X6 022 RPMT 10T3	1.787

RCKT 1204/1606 ZCC



KOD	Stok Stock	Inter Cooland	Kesici Uç Uyumluluğu / Insert Suitability	FIYAT PRICE
			ISO RCKT 1204/1606	TL
TK RCKT 12 000 ISO	✓	✓	EMR 40X4 016 RCKT 1204	1.233
TK RCKT 12 001 ISO	✓	✓	EMR 50X5 022 RCKT 1204	1.403
TK RCKT 12 002 ISO	✓	✓	EMR 63X6 022 RCKT 1204	1.787
TK RCKT 16 005 ISO	✓	✓	EMR 80X5 027 RCKT 1606	2.127
TK RCKT 12 006 ISO	✓	✓	EMR 80X7 027 RCKT 1204	2.085

ROMX 2006 WLTR



KOD	Stok Stock	Inter Cooland	Kesici Uç Uyumluluğu / Insert Suitability	FIYAT PRICE
			WLTR ROMX 2006	TL
TK ROMX 20 003 WLTR	✓	✗	EMR 125X6 040 ROMX 2006	3.319
TK ROMX 20 004 WLTR	✓	✗	EMR 160X7 040 ROMX 2006	3.829
TK ROMX 20 005 WLTR	✓	✗	EMR 200X9 060 ROMX 2006	5.529



VIDALI TARAMALAR SCREW TYPE

90° AP..1003/1604 ISO



KOD	Stok Stock	Inter Cooland	Kesici Uç Uyumluluğu / Insert Suitability		FIYAT PRICE
			ISO AP.. 1003/1604		TL
VT AP..10 001 ISO	✓	X	VT EM90 25X3 M12 AP.1003		1.532
VT AP..10 002 ISO	✓	X	VT EM90 32X4 M16 AP.1003		1.618
VT AP..10 003 ISO	✓	X	VT EM90 35X4 M16 AP.1003		1.660
VT AP..10 005 ISO	✓	X	VT EM90 40X5 M16 AP.1003		1.748
VT AP..10 007 ISO	✓	X	VT EM90 16X2 M08 AP.1003		1.382
VT AP..10 008 ISO	✓	X	VT EM90 20X3 M10 AP.1003		1.403
VT AP..16 007 ISO	✓	X	VT EM90 25X2 M12 AP.1604		1.532
VT AP..16 008 ISO	✓	X	VT EM90 32X3 M16 AP.1604		1.660
VT AP..16 009 ISO	✓	X	VT EM90 40X4 M16 AP.1604		1.748

90° APMT 11T3



KOD	Stok Stock	Inter Cooland	Kesici Uç Uyumluluğu / Insert Suitability		FIYAT PRICE
			APMT 11T3		TL
VT APMT 11 001	✓	X	VT EM90 20X3 M10 APMT 11T3		1.403
VT APMT 11 003	✓	X	VT EM90 25X4 M12 APMT 11T3		1.532
VT APMT 11 004	✓	X	VT EM90 32X4 M16 APMT 11T3		1.618

90° XNEX 0403 SCO



KOD	Stok Stock	Inter Cooland	Kesici Uç Uyumluluğu / Insert Suitability		FIYAT PRICE
			SCO XNEX 0403		TL
VT XNEX 04 000 SCO	✓	✓	VT EM90 25X4 M12 XNEX 0403		1.748
VT XNEX 04 001 SCO	✓	✓	VT EM90 32X5 M16 XNEX 0403		1.872
VT XNEX 04 003 SCO	✓	✓	VT EM90 32X4 M16 XNEX 0403		1.723

90° XOMX 1204 SCO



KOD	Stok Stock	Inter Cooland	Kesici Uç Uyumluluğu / Insert Suitability	FIYAT PRICE
			SCO XOMX 1204..	TL
VT XOMX 12 001 SCO (S)	✓	✓	VT EM90 25X3 M12 XOMX 1204 inter cooland	1.575
VT XOMX 12 002 SCO (S)	✓	✓	VT EM90 32X4 M16 XOMX 1204 inter cooland	1.660

90° 3PKT 1004 TT



KOD	Stok Stock	Inter Cooland	Kesici Uç Uyumluluğu / Insert Suitability	FIYAT PRICE
			TT 3PKT 1004	TL
VT 3PKT 10 002 TT	✓	✗	VT EM90 32X4 M16 3PKT 1004	1.787
VT 3PKT 10 004 TT	✓	✗	VT EM90 42X4 M16 3PKT 1004	2.002

90° BOMT 1304 INGRSL



KOD	Stok Stock	Inter Cooland	Kesici Uç Uyumluluğu / Insert Suitability	FIYAT PRICE
			INGRSL BOMT 1304	TL
VT BOMT 13 001 INGRSL	✓	✗	VT EM90 25X3 M12 BOMT 1304	1.532
VT BOMT 13 002 INGRSL	✓	✗	VT EM90 32X4 M16 BOMT 1304	1.660

90° AOMT 1605 INGRSL



KOD	Stok Stock	Inter Cooland	Kesici Uç Uyumluluğu / Insert Suitability	FIYAT PRICE
			INGRSL AOMT 160508	TL
VT AOMT 16 001 INGRSL	✓	X	VT EM90 25X2 M12 AOMT 1605	1.532
VT AOMT 16 002 INGRSL	✓	X	VT EM90 32X3 M16 AOMT 1605	1.660
VT AOMT 16 003 INGRSL	✓	X	VT EM90 40X4 M16 AOMT 1605	1.748

90° TNGX 1004 PRMT



KOD	Stok Stock	Inter Cooland	Kesici Uç Uyumluluğu / Insert Suitability	FIYAT PRICE
			PRMT TNGX 1004	TL
VT TNGX 10 001 PRMT	✓	✓	VT EM90 25X4 M12 TNGX 1004	1.660
VT TNGX 10 002 PRMT	✓	✓	VT EM90 32X5 M16 TNGX 1004	1.917

90° APMT 1135 SNG



KOD	Stok Stock	Inter Cooland	Kesici Uç Uyumluluğu / Insert Suitability	FIYAT PRICE
			SNG APMT 1135	TL
VT APMT 11 003 SNG	✓	✓	VT EM90 25X3 M12 APMT 1135	1.592
VT APMT 11 004 SNG	✓	✓	VT EM90 32X4 M16 APMT 1135	1.726

90° XDKT 1505 CRTZT



KOD	Stok Stock	Inter Cooland	Kesici Uç Uyumluluğu / Insert Suitability	FIYAT PRICE
			CRTZ XDKT 1505	TL
VT XDKT 15 001 CRTZ	✓	✗	VT EM90 25X2 M12 XDKT 1505	1.532
VT XDKT 15 002 CRTZ	✓	✗	VT EM90 32X3 M16 XDKT 1505	1.639

90° XDHT 1904 CRTZT



KOD	Stok Stock	Inter Cooland	Kesici Uç Uyumluluğu / Insert Suitability	FIYAT PRICE
			CRTZ XDHT 1904	TL
VT XDHT 19 001 CRTZ	✓	✗	VT EM90 25X2 M12 XDHT 1904	1.532
VT XDHT 19 002 CRTZ	✓	✗	VT EM90 40X4 M16 XDHT 1904	1.787

90° APMT 11T308 KRLY



KOD	Stok Stock	Inter Cooland	Kesici Uç Uyumluluğu / Insert Suitability	FIYAT PRICE
			KRLY APMT 11T308	TL
VT APMT 11 001 KRLY	✓	✓	VT EM90 20X3 M10 APMT 11T308	1.492
VT APMT 11 003 KRLY	✓	✓	VT EM90 32X4 M16 APMT 11T308	1.700

90° XNKT 0604 KRLY



90° XNKT 0805 KRLY



90° 4NKT 0603 TT



RD..1003/12T3/1604 ISO



KOD	Stok Stock	Inter Cooland	Kesici Uç Uyumluluğu / Insert Suitability	FİYAT PRICE
			KRLY XNKT 0604	TL
VT XNKT 06 001 KRLY	✓	✓	VT EM90 25X3 M12 XNKT 0604	1.748
VT XNKT 06 002 KRLY	✓	✓	VT EM90 32X4 M16 XNKT 0604	1.872
VT XNKT 06 004 KRLY	✓	✓	VT EM90 42X5 M16 XNKT 0604	2.002
VT XNKT 06 006 KRLY	✓	✓	VT EM90 20X2 M10 XNKT 0604	1.660

KOD	Stok Stock	Inter Cooland	Kesici Uç Uyumluluğu / Insert Suitability	FİYAT PRICE
			KRLY XNKT 0805	TL
VT XNKT 08 001 KRLY	✓	✓	VT EM90 32X3 M16 XNKT 0805	1.872
VT XNKT 08 002 KRLY	✓	✓	VT EM90 40X4 M16 XNKT 0805	2.002
VT XNKT 08 003 KRLY	✓	✓	VT EM90 42X4 M16 XNKT 0805	2.044

KOD	Stok Stock	Inter Cooland	Kesici Uç Uyumluluğu / Insert Suitability	FİYAT PRICE
			TT 4NKT 0603	TL
VT 4NKT 06 004 TT	✓	✓	VT EM90 21X3 M10 4NKT 0603	1.829
VT 4NKT 06 005 TT	✓	✓	VT EM90 26X3 M12 4NKT 0603	1.748
VT 4NKT 06 006 TT	✓	✓	VT EM90 32X4 M16 4NKT 0603	2.002

KOD	Stok Stock	Inter Cooland	Kesici Uç Uyumluluğu / Insert Suitability	FİYAT PRICE
			ISO RD.. 1003/12T3/1604	TL
VT RD..10 001 ISO	✓	✓	VT EMR 25X2 M12 RD..1003	1.403
VT RD..10 003 ISO	✓	✓	VT EMR 32X4 M16 RD..1003	1.575
VT RD..10 004 ISO	✓	✓	VT EMR 35X4 M16 RD..1003	1.618
VT RD..10 005 ISO	✓	✓	VT EMR 40X4 M16 RD..1003	1.660
VT RD..10 006 ISO	✓	✓	VT EMR 42X5 M16 RD..1003	1.700
VT RD..10 007 ISO	✓	✓	VT EMR 20X2 M10 RD..1003	1.322
VT RD..12 007 ISO	✓	✓	VT EMR 25X2 M12 RD..12T3	1.449
VT RD..12 008 ISO	✓	✓	VT EMR 32X3 M16 RD..12T3	1.575
VT RD..12 009 ISO	✓	✓	VT EMR 35X3 M16 RD..12T3	1.575
VT RD..12 011 ISO	✓	✓	VT EMR 42X4 M16 RD..12T3	1.700
VT RD..16 012 ISO	✓	✓	VT EMR 32X2 M16 RD..1604	1.575
VT RD..16 013 ISO	✓	✓	VT EMR 40X2 M16 RD..1604	1.660
VT RD..08 017 ISO	✓	✓	VT EMR 16X2 M8 RD..0803	1.194

RPMW 1003 ISO



KOD	Stok Stock	Inter Cooland	Kesici Uç Uyumluluğu / Insert Suitability	FIYAT PRICE
			ISO RPMW 1003	TL
VT RPMW 10 001 ISO	✓	✓	VT EMR 20X2 M10 RPMW 1003	1.532
VT RPMW 10 002 ISO	✓	✓	VT EMR 25X2 M12 RPMW 1003	1.575
VT RPMW 10 003 ISO	✓	✓	VT EMR 32X4 M16 RPMW 1003	1.660
VT RPMW 10 004 ISO	✓	✓	VT EMR 42X5 M16 RPMW 1003	1.787

RDHX 1003 KYCR



KOD	Stok Stock	Inter Cooland	Kesici Uç Uyumluluğu / Insert Suitability	FIYAT PRICE
			KYCR RDHX 1003	TL
VT RDHX 10 001 KYCR	✓	✓	VT EMR 32X4 M16 RDHX 1003	1.723
VT RDHX 10 002 KYCR	✓	✓	VT EMR 42X5 M16 RDHX 1003	1.943

RPMT 10T3 KYCR



KOD	Stok Stock	Inter Cooland	Kesici Uç Uyumluluğu / Insert Suitability	FIYAT PRICE
			RPMT KYCR 10T3	TL
VT RPMT 10 001 KYCR	✓	✓	VT EMR 25X3 M12 RPMT 10T3	1.458
VT RPMT 10 003 KYCR	✓	✓	VT EMR 32X4 M16 RPMT 10T3	1.682
VT RPMT 10 006 KYCR	✓	✓	VT EMR 42X5 M16 RPMT 10T3	1.857

RPMT 1204 KYCR



KOD	Stok Stock	Inter Cooland	Kesici Uç Uyumluluğu / Insert Suitability		FIYAT PRICE
			RPMT KYCR 1204		TL
VT RPMT 12 001 KYCR	X	✓	VT EMR 25X2 M12 RPMT 1204		1.417
VT RPMT 12 002 KYCR	X	✓	VT EMR 32X3 M16 RPMT 1204		1.682

ROHX 1203/1604 ZCC



KOD	Stok Stock	Inter Cooland	Kesici Uç Uyumluluğu / Insert Suitability		FIYAT PRICE
			ZCC ROHX 1203/1604		TL
VT ROHX 16 002 ZCC	✓	X	VT EMR D16 M8 ROHX 1604		1.946
VT ROHX 20 003 ZCC	✓	X	VT EMR D20 M10 ROHX 2005		2.035

XPHT 32 R16 ZCC



KOD	Stok Stock	Inter Cooland	Kesici Uç Uyumluluğu / Insert Suitability		FIYAT PRICE
			ZCC XPHT 32 R16		TL
VT XPHT 25 001 ZCC	✓	✓	VT EMR 25X2 M12 XPHT 25 R12.5		1.458
VT XPHT 32 002 ZCC	✓	✓	VT EMR 32X2 M16 XPHT 32 R16		1.592

SDMT 06T2/09T3/1204 ZCC



KOD	Stok Stock	Inter Cooland	Kesici Uç Uyumluluğu / Insert Suitability	FIYAT PRICE
			ZCC SDMT 06T2/09T3/1204	TL
VT SDMT 09 003 ZCC	✓	✓	VT BMR 25X2 M12 SDMT 09T3	1.483
VT SDMT 09 004 ZCC	✓	✓	VT BMR 25X3 M12 SDMT 09T3	1.483
VT SDMT 09 005 ZCC	✓	✓	VT BMR 32X3 M16 SDMT 09T3	1.638
VT SDMT 09 006 ZCC	✓	✓	VT BMR 35X4 M16 SDMT 09T3	1.682
VT SDMT 09 007 ZCC	✓	✓	VT BMR 40X4 M16 SDMT 09T3	1.817
VT SDMT 09 009 ZCC	✓	✓	VT BMR 42X5 M16 SDMT 09T3	1.859

SOEW 0803 PLBT



KOD	Stok Stock	Inter Cooland	Kesici Uç Uyumluluğu / Insert Suitability	FIYAT PRICE
			PLBT SOEW 0803	TL
VT SOEW 08 001 PLBT	✓	✓	VT BMR 32X4 M16 SOEW 0803	1.575
VT SOEW 08 002 PLBT	✓	✓	VT BMR 35X4 M16 SOEW 0803	1.618
VT SOEW 08 003 PLBT	✓	✓	VT BMR 40X5 M16 SOEW 0803	1.700
VT SOEW 08 004 PLBT	✓	✓	VT BMR 25X3 M12 SOEW 0803	1.532

SDMX 09T3 PLBT



KOD	Stok Stock	Inter Cooland	Kesici Uç Uyumluluğu / Insert Suitability	FIYAT PRICE
			PLBT SDMX 09T312	TL
VT SDMX 09 001 PLBT	✓	✓	VT BMR 25X3 M12 SDMX 09T3	1.532
VT SDMX 09 003 PLBT	✓	✓	VT BMR 32X4 M16 SDMX 09T3	1.618
VT SDMX 09 004 PLBT	✓	✓	VT BMR 35X5 M16 SDMX 09T3	1.660
VT SDMX 09 005 PLBT	✓	✓	VT BMR 42X6 M16 SDMX 09T3	1.829

XDHW 04/06/09 PLBT



KOD	Stok Stock	Inter Cooland	Kesici Uç Uyumluluğu / Insert Suitability	FİYAT PRICE
			PLBT - VNDRT XDHW 04/06/09	TL
VT XDHW 04 003 PLBT			VT BMR 16X4 M08 XDHW 0401	1.532
VT XDHW 06 001 PLBT	✓	✓	VT BMR 16X2 M08 XDHW 0602	1.449
VT XDHW 06 003 PLBT	✓	✓	VT BMR 32X5 M16 XDHW 0602	1.787
VT XDHW 06 004 PLBT	✓	✓	VT BMR 35X5 M16 XDHW 0602	1.787
VT XDHW 06 005 PLBT	✓	✓	VT BMR 20X3 M10 XDHW 0602	1.532
VT XDHW 06 006 PLBT	✓	✓	VT BMR 42X6 M16 XDHW 0602	1.829
VT XDHW 06 007 PLBT	✓	✓	VT BMR 25X4 M12 XDHW 0602	1.660
VT XDHW 06 008 PLBT	✓	✓	VT BMR 17X2 M08 XDHW 0602	1.449
VT XDHW 06 009 PLBT	✓	✓	VT BMR 21X3 M10 XDHW 0602	1.532

SEMT 09T307 PLBT



KOD	Stok Stock	Inter Cooland	Kesici Uç Uyumluluğu / Insert Suitability	FİYAT PRICE
			SEMT 09T307	TL
VT SEMT 09T3 002	✗	✓	VT BMR 35X4 M16 SEMT 09T307	1.618
VT SEMT 09T3 003	✗	✓	VT BMR 42X5 M16 SEMT 09T307	1.748

XCNT 09T3 LMT FT



KOD	Stok Stock	Inter Cooland	Kesici Uç Uyumluluğu / Insert Suitability	FİYAT PRICE
			LMT XCNT 09T3	TL
VT XCNT 09 002 LMT FT	✗	✓	VT BMR 32X4 M16 XCNT 09T3	1.660
VT XCNT 09 003 LMT FT	✗	✓	VT BMR 42X4 M16 XCNT 09T3	1.917

WNMX 09T3 KRLY



KOD	Stok Stock	Inter Cooland	Kesici Uç Uyumluluğu / Insert Suitability		FIYAT PRICE
			KRLY WNMX 09T316		TL
VT WNMX 09 001 KRLY	✓	✓	VT BMR 25X2 M12 WNMX 09T3		1.427
VT WNMX 09 002 KRLY	✓	✓	VT BMR 32X3 M16 WNMX 09T3		1.660
VT WNMX 09 004 KRLY	✓	✓	VT BMR 35X4 M16 WNMX 09T3		1.748
VT WNMX 09 005 KRLY	✓	✓	VT BMR 40X4 M16 WNMX 09T3		1.853
VT WNMX 09 006 KRLY	✓	✓	VT BMR 42X4 M16 WNMX 09T3		1.917

WNMX 0603 KRLY



KOD	Stok Stock	Inter Cooland	Kesici Uç Uyumluluğu / Insert Suitability		FIYAT PRICE
			KRLY WNMX 0603		TL
VT WNMX 06 001 KRLY	✓	✓	VT BMR 16X2 M08 WNMX 0603		1.363
VT WNMX 06 002 KRLY	✓	✓	VT BMR 20X3 M10 WNMX 0603		1.575
VT WNMX 06 003 KRLY	✓	✓	VT BMR 25X3 M12 WNMX 0603		1.660
VT WNMX 06 004 KRLY	✓	✓	VT BMR 25X4 M12 WNMX 0603		1.700
VT WNMX 06 005 KRLY	✓	✓	VT BMR 35X5 M16 WNMX 0603		1.829
VT WNMX 06 006 KRLY	✓	✓	VT BMR 32X5 M16 WNMX 0603		1.829

LNMT 0603 KRLY



KOD	Stok Stock	Inter Cooland	Kesici Uç Uyumluluğu / Insert Suitability		FIYAT PRICE
			KRLY LNMT 060310		TL
VT LNMT 06 002 KRLY	✓	✓	VT BMR 35X5 M16 LN..0603		1.700
VT LNMT 06 003 KRLY	✓	✓	VT BMR 40X6 M16 LN..0603		1.958

LNMX 060310 KRLY



KOD	Stok Stock	Inter Cooland	Kesici Uç Uyumluluğu / Insert Suitability	FİYAT PRICE
			KRLY LNMX 0603	
VT LNMX 06 001 KRLY	✓	✓	VT BMR 16X2 M8 LNMX 0603	1.492
VT LNMX 06 002 KRLY	✓	✓	VT BMR 20X3 M10 LNMX 0603	1.492
VT LNMX 06 003 KRLY	✓	✓	VT BMR 25X4 M12 LNMX 0603	1.575
VT LNMX 06 004 KRLY	✓	✓	VT BMR 35X5 M16 LNMX 0603	1.700
VT LNMX 06 005 KRLY	✓	✓	VT BMR 42X6 M16 LNMX 0603	1.958
VT LNMX 06 006 KRLY	✓	✓	VT BMR 32X5 M16 LNMX 0603	1.700
VT LNMX 06 007 KRLY	✓	✓	VT BMR 40X6 M16 LNMX 0603	1.958
VT LNMX 06 008 KRLY	✓	✓	VT BMR 17X2 M08 LNMX 0603	1.492
VT LNMX 06 009 KRLY	✓	✓	VT BMR 21X3 M10 LNMX 0603	1.492
VT LNMX 06 010 KRLY	✓	✓	VT BMR 26X4 M12 LNMX 0603	1.575

BLM. 0603 TT



KOD	Stok Stock	Inter Cooland	Kesici Uç Uyumluluğu / Insert Suitability	FİYAT PRICE
			TT BLM. 0603	
VT BLM 06 001 TT	✓	✓	VT BMR 32X5 M16 BLMP 0603	1.808
VT BLM 06 002 TT	✓	✓	VT BMR 42X6 M16 BLMP 0603	2.127
VT BLM 06 003 TT	✓	✓	VT BMR 20X3 M10 BLMP 0603	1.660
VT BLM 06 004 TT	✓	✓	VT BMR 25X4 M12 BLMP 0603	1.748
VT BLM 06 005 TT	✓	✓	VT BMR 40X6 M16 BLMP 0603	2.085

SOMT 1004/1404 KYCR



KOD	Stok Stock	Inter Cooland	Kesici Uç Uyumluluğu / Insert Suitability	FİYAT PRICE
			KYCR SOMT 1004/1404	
VT SOMT 10 001 KYCR	✓	✓	VT BMR 32X3 M16 SOMT 10	1.682
VT SOMT 10 002 KYCR	✓	✓	VT BMR 35X3 M16 SOMT 10	1.682
VT SOMT 10 003 KYCR	✓	✓	VT BMR 40X4 M16 SOMT 10	1.817
VT SOMT 10 004 KYCR	✓	✓	VT BMR 42X4 M16 SOMT 10	1.817
VT SOMT 14 005 KYCR	✓	✓	VT BMR 42X3 M16 SOMT 14	1.901

LOGU 0303 KYCR



KOD	Stok Stock	Inter Cooland	Kesici Uç Uyumluluğu / Insert Suitability	FIYAT PRICE
			KYCR LOGU 0303	TL
VT LOGU 03 001 KYCR	✓	✓	VT BMR 20X3 M10 LOGU 0303	1.974
VT LOGU 03 002 KYCR	✓	✓	VT BMR 25X4 M12 LOGU 0303	2.069
VT LOGU 03 003 KYCR	✓	✓	VT BMR 32X5 M16 LOGU 0303	2.160
VT LOGU 03 004 KYCR	✓	✓	VT BMR 40X6 M16 LOGU 0303	2.252
VT LOGU 03 005 KYCR	✓	✓	VT BMR 42X6 M16 LOGU 0303	2.252
VT LOGU 03 006 KYCR	✓	✓	VT BMR 35X5 M16 LOGU 0303	2.160
VT LOGU 03 007 KYCR	✓	✓	VT BMR 17X2 M8 LOGU 0303	1.701

P26335 R10/R14 WLTR



KOD	Stok Stock	Inter Cooland	Kesici Uç Uyumluluğu / Insert Suitability	FIYAT PRICE
			WLTR P26335 R10/R14	TL
VT P2633 R10 004 WLTR	✓	✓	VT BMR 40X5 M16 P26..R-10	1.872
VT P2633 R14 002 WLTR	✗	✗	VT BMR 32X3 M16 P26..R-14	1.575

LNMU 0303 TNG



KOD	Stok Stock	Inter Cooland	Kesici Uç Uyumluluğu / Insert Suitability	FIYAT PRICE
			TNGLY LNMU 0303	TL
VT LNMU 03 001 TNG	✓	✓	VT BMR 25X4 M12 LNMU 0303	1.909
VT LNMU 03 002 TNG	✓	✓	VT BMR 32X5 M16 LNMU 0303	2.035
VT LNMU 03 004 TNG	✓	✓	VT BMR 40X6 M16 LNMU 0303	2.074
VT LNMU 03 005 TNG	✓	✓	VT BMR 20X3 M10 LNMU 0303	1.744
VT LNMU 03 006 TNG	✓	✓	VT BMR 32X4 M16 LNMU 0303	2.035
VT LNMU 03 007 TNG	✓	✓	VT BMR 35X4 M16 LNMU 0303	2.035
VT LNMU 03 008 TNG	✓	✓	VT BMR 42X5 M16 LNMU 0303	2.199
VT LNMU 03 009 TNG	✓	✓	VT BMR 42X6 M16 LNMU 0303	2.199

BNGX 10T3 PRMT



KOD	Stok Stock	Inter Cooland	Kesici Uç Uyumluluğu / Insert Suitability		FIYAT PRICE
			PRMT BNGX 10T3		TL
VT BNGX 10 001 PRMT	X	✓	VT BMR 25X4 M12 BNGX 10T3		1.660
VT BNGX 10 002 PRMT	X	✓	VT BMR 32X5 M16 BNGX 10T3		1.917

SDMT 1004 BHLR



KOD	Stok Stock	Inter Cooland	Kesici Uç Uyumluluğu / Insert Suitability		FIYAT PRICE
			BHLR SDMT 1004		TL
VT SDMT 10 001 BHLR	✓	✓	VT BMR 32X3 M16 SDMT 1004		1.660
VT SDMT 10 002 BHLR	✓	✓	VT BMR 25X2 M12 SDMT 1004		1.532

SPMW 1204 SNG



KOD	Stok Stock	Inter Cooland	Kesici Uç Uyumluluğu / Insert Suitability		FIYAT PRICE
			SNG SPMW 1204		TL
VT SPMW 12 001 SNG	✓	✓	VT BMR 32X2 M16 SPMW 1204		1.638
VT SPMW 12 002 SNG	✓	✓	VT BMR 40X3 M16 SPMW 1204		1.857

SOMW 080315 SNG



KOD	Stok Stock	Inter Cooland	Kesici Uç Uyumluluğu / Insert Suitability	FİYAT PRICE
			SNG SOMW 0803	TL
VT SOMW 08 001 SNG	✓	✓	VT BMR 20X2 M10 SOMW 0803	1.458
VT SOMW 08 002 SNG	✓	✓	VT BMR 25X3 M12 SOMW 0803	1.592
VT SOMW 08 003 SNG	✓	✓	VT BMR 32X4 M16 SOMW 0803	1.726
VT SOMW 08 004 SNG	✓	✓	VT BMR 42X5 M16 SOMW 0803	1.857
VT SOMW 08 005 SNG	✓	✓	VT BMR 40X5 M16 SOMW 0803	1.857

XDHX 06/10 SNG



KOD	Stok Stock	Inter Cooland	Kesici Uç Uyumluluğu / Insert Suitability	FİYAT PRICE
			SNG XDHX 06/10	TL
VT XDHX 06 001 SNG	✓	✓	VT BMR 20X3 M10 XDHX06	1.638
VT XDHX 06 002 SNG	✓	✓	VT BMR 25X4 M12 XDHX06	1.726
VT XDHX 10 004 SNG	✓	✓	VT BMR 35X3 M16 XDHX10	1.768

YNGX 0603 SNG



KOD	Stok Stock	Inter Cooland	Kesici Uç Uyumluluğu / Insert Suitability	FİYAT PRICE
			SNG YNGX 0603	TL
VT YNGX 06 002 SNG	✓	✓	VT EM90 20X3 M10 YNGX 0603	1.901
VT YNGX 06 003 SNG	✓	✓	VT EM90 25X3 M12 YNGX 0603	1.992
VT YNGX 06 004 SNG	✓	✓	VT EM90 32X4 M16 YNGX 0603	2.081
VT YNGX 06 005 SNG	✓	✓	VT EM90 40X5 M16 YNGX 0603	2.168



U - DRILLER U - DRILLS

DRILL WCM. D2



KOD	Stok Stock	Inter Cooland	Kesici Uç Uyumluluğu / Insert Suitability		FİYAT PRICE TL
			WCM.		
WCM D2 016 ISO	✓	✓	DRILL 16XD2 WCM 030208		1.991
WCM D2 016,5 ISO	✓	✓	DRILL 16,5XD2 WCM 030208		1.991
WCM D2 017 ISO	✓	✓	DRILL 17XD2 WCM 030208		1.991
WCM D2 017,5 ISO	✓	✓	DRILL 17,5XD2 WCM 030208		1.991
WCM D2 018 ISO	✓	✓	DRILL 18XD2 WCM 030208		1.991
WCM D2 018,5 ISO	✓	✓	DRILL 18,5XD2 WCM 030208		1.991
WCM D2 019 ISO	✓	✓	DRILL 19XD2 WCM 030208		1.991
WCM D2 019,5 ISO	✓	✓	DRILL 19,5XD2 WCM 030208		1.991
WCM D2 020 ISO	✓	✓	DRILL 20XD2 WCM 040208		2.050
WCM D2 020,5 ISO	✓	✓	DRILL 20,5XD2 WCM 040208		2.050
WCM D2 021 ISO	✓	✓	DRILL 21XD2 WCM 040208		2.050
WCM D2 021,5 ISO	✓	✓	DRILL 21,5XD2 WCM 040208		2.050
WCM D2 022 ISO	✓	✓	DRILL 22XD2 WCM 040208		2.050
WCM D2 022,5 ISO	✓	✓	DRILL 22,5XD2 WCM 040208		2.050
WCM D2 023 ISO	✓	✓	DRILL 23XD2 WCM 040208		2.050
WCM D2 023,5 ISO	✓	✓	DRILL 23,5XD2 WCM 040208		2.177
WCM D2 024 ISO	✓	✓	DRILL 24XD2 WCM 050308		2.177
WCM D2 024,5 ISO	✓	✓	DRILL 24,5XD2 WCM 050308		2.177
WCM D2 025 ISO	✓	✓	DRILL 25XD2 WCM 050308		2.177
WCM D2 025,5 ISO	✓	✓	DRILL 25,5XD2 WCM 050308		2.177
WCM D2 026 ISO	✓	✓	DRILL 26XD2 WCM 050308		2.177
WCM D2 026,5 ISO	✓	✓	DRILL 26,5XD2 WCM 050308		2.177
WCM D2 027 ISO	✓	✓	DRILL 27XD2 WCM 050308		2.177
WCM D2 027,5 ISO	✓	✓	DRILL 27,5XD2 WCM 050308		2.177
WCM D2 028 ISO	✓	✓	DRILL 28XD2 WCM 050308		2.177
WCM D2 028,5 ISO	✓	✓	DRILL 28,5XD2 WCM 050308		2.177
WCM D2 029 ISO	✓	✓	DRILL 29XD2 WCM 050308		2.177
WCM D2 029,5 ISO	✓	✓	DRILL 29,5XD2 WCM 050308		2.177
WCM D2 030 ISO	✓	✓	DRILL 30XD2 WCM 060308		2.464
WCM D2 031 ISO	✓	✓	DRILL 31XD2 WCM 06T308		2.464
WCM D2 032 ISO	✓	✓	DRILL 32XD2 WCM 06T308		2.464
WCM D2 033 ISO	✓	✓	DRILL 33XD2 WCM 06T308		2.464
WCM D2 034 ISO	✓	✓	DRILL 34XD2 WCM 06T308		2.464
WCM D2 035 ISO	✓	✓	DRILL 35XD2 WCM 06T308		2.464
WCM D2 036 ISO	✓	✓	DRILL 36XD2 WCM 06T308		2.464
WCM D2 037 ISO	✓	✓	DRILL 37XD2 WCM 06T308		2.464
WCM D2 038 ISO	✓	✓	DRILL 38XD2 WCM 06T308		2.464
WCM D2 039 ISO	✓	✓	DRILL 39XD2 WCM 06T308		2.464
WCM D2 040 ISO	✓	✓	DRILL 40XD2 WCM 06T308		2.464
WCM D2 041 ISO	✓	✓	DRILL 41XD2 WCM 06T308		2.545
WCM D2 042 ISO	✓	✓	DRILL 42XD2 WCM 06T308		2.545
WCM D2 043 ISO	✓	✓	DRILL 43XD2 WCM 06T308		2.545
WCM D2 044 ISO	✓	✓	DRILL 44XD2 WCM 06T308		2.545
WCM D2 045 ISO	✓	✓	DRILL 45XD2 WCM..080412		2.670
WCM D2 046 ISO	✓	✓	DRILL 46XD2 WCM..080412		2.875
WCM D2 047 ISO	✓	✓	DRILL 47XD2 WCM..080412		3.081
WCM D2 048 ISO	✓	✓	DRILL 48XD2 WCM..080412		3.204
WCM D2 049 ISO	✓	✓	DRILL 49XD2 WCM..080412		3.328
WCM D2 050 ISO	✓	✓	DRILL 50XD2 WCM..080412		3.494

DRILL WCM. D3



KOD	Stok Stock	Inter Cooland	Kesici Uç Uyumluluğu / Insert Suitability	FIYAT PRICE
			WCM.	TL
WCM.D3 015,5 ISO	✓	✓	DRILL 15,5XD3 WCM 030208	2.134
WCM.D3 016 ISO	✓	✓	DRILL 16XD3 WCM 030208	2.134
WCM.D3 016,5 ISO	✓	✓	DRILL 16,5XD3 WCM 030208	2.134
WCM.D3 017 ISO	✓	✓	DRILL 17XD3 WCM 030208	2.134
WCM.D3 017,5 ISO	✓	✓	DRILL 17,5XD3 WCM 030208	2.134
WCM.D3 018 ISO	✓	✓	DRILL 18XD3 WCM 030208	2.134
WCM.D3 018,5 ISO	✓	✓	DRILL 18,5XD3 WCM 030208	2.134
WCM.D3 019 ISO	✓	✓	DRILL 19XD3 WCM 030208	2.134
WCM.D3 019,5 ISO	✓	✓	DRILL 19,5XD3 WCM 030208	2.134
WCM.D3 020 ISO	✓	✓	DRILL 20XD3 WCM 040208	2.260
WCM.D3 020,5 ISO	✓	✓	DRILL 20,5XD3 WCM 040208	2.260
WCM.D3 021 ISO	✓	✓	DRILL 21XD3 WCM 040208	2.260
WCM.D3 021,5 ISO	✓	✓	DRILL 21,5XD3 WCM 040208	2.260
WCM.D3 022 ISO	✓	✓	DRILL 22XD3 WCM 040208	2.260
WCM.D3 022,5 ISO	✓	✓	DRILL 22,5XD3 WCM 040208	2.260
WCM.D3 023 ISO	✓	✓	DRILL 23XD3 WCM 040208	2.260
WCM.D3 023,5 ISO	✓	✓	DRILL 23,5XD3 WCM 040208	2.260
WCM.D3 024 ISO	✓	✓	DRILL 24XD3 WCM 050308	2.301
WCM.D3 024,5 ISO	✓	✓	DRILL 24,5XD3 WCM 050308	2.301
WCM.D3 025 ISO	✓	✓	DRILL 25XD3 WCM 050308	2.301
WCM.D3 025,5 ISO	✓	✓	DRILL 25,5XD3 WCM 050308	2.301
WCM.D3 026 ISO	✓	✓	DRILL 26XD3 WCM 050308	2.301
WCM.D3 026,5 ISO	✓	✓	DRILL 26,5XD3 WCM 050308	2.301
WCM.D3 027 ISO	✓	✓	DRILL 27XD3 WCM 050308	2.301
WCM.D3 027,5 ISO	✓	✓	DRILL 27,5XD3 WCM 050308	2.301
WCM.D3 028 ISO	✓	✓	DRILL 28XD3 WCM 050308	2.301
WCM.D3 028,5 ISO	✓	✓	DRILL 28,5XD3 WCM 050308	2.301
WCM.D3 029 ISO	✓	✓	DRILL 29XD3 WCM 050308	2.301
WCM.D3 029,5 ISO	✓	✓	DRILL 29,5XD3 WCM 050308	2.301
WCM.D3 030 ISO	✓	✓	DRILL 30XD3 WCM 06T308	2.505
WCM.D3 030,5 ISO	✓	✓	DRILL 30,5XD3 WCM 06T308	2.505
WCM.D3 031 ISO	✓	✓	DRILL 31XD3 WCM 06T308	2.505
WCM.D3 031,5 ISO	✓	✓	DRILL 31,5XD3 WCM 06T308	2.505
WCM.D3 032 ISO	✓	✓	DRILL 32XD3 WCM 06T308	2.505
WCM.D3 032,5 ISO	✓	✓	DRILL 32,5XD3 WCM 06T308	2.505
WCM.D3 033 ISO	✓	✓	DRILL 33XD3 WCM 06T308	2.505
WCM.D3 033,5 ISO	✓	✓	DRILL 33,5XD3 WCM 06T308	2.505
WCM.D3 034 ISO	✓	✓	DRILL 34XD3 WCM 06T308	2.505
WCM.D3 034,5 ISO	✓	✓	DRILL 34,5XD3 WCM 06T308	2.505
WCM.D3 035 ISO	✓	✓	DRILL 35XD3 WCM 06T308	2.505
WCM.D3 035,5 ISO	✓	✓	DRILL 35,5XD3 WCM 06T308	2.505
WCM.D3 036 ISO	✓	✓	DRILL 36XD3 WCM 06T308	2.505
WCM.D3 036,5 ISO	✓	✓	DRILL 36,5XD3 WCM 06T308	2.505
WCM.D3 037 ISO	✓	✓	DRILL 37XD3 WCM 06T308	2.505
WCM.D3 037,5 ISO	✓	✓	DRILL 37,5XD3 WCM 06T308	2.505
WCM.D3 038 ISO	✓	✓	DRILL 38XD3 WCM 06T308	2.505
WCM.D3 038,5 ISO	✓	✓	DRILL 38,5XD3 WCM 06T308	2.505
WCM.D3 039 ISO	✓	✓	DRILL 39XD3 WCM 06T308	2.505
WCM.D3 039,5 ISO	✓	✓	DRILL 39,5XD3 WCM 06T308	2.505
WCM.D3 040 ISO	✓	✓	DRILL 40XD3 WCM 06T308	2.505
WCM.D3 041 ISO	✓	✓	DRILL 41XD3 WCM 06T308	2.792
WCM.D3 042 ISO	✓	✓	DRILL 42XD3 WCM 06T308	2.792
WCM.D3 043 ISO	✓	✓	DRILL 43XD3 WCM 06T308	2.792
WCM.D3 044 ISO	✓	✓	DRILL 44XD3 WCM 06T308	2.792
WCM.D3 045 ISO	✓	✓	DRILL 45XD3 WCM 080412	2.917
WCM.D3 046 ISO	✓	✓	DRILL 46XD3 WCM 080412	3.081
WCM.D3 047 ISO	✓	✓	DRILL 47XD3 WCM 080412	3.204
WCM.D3 048 ISO	✓	✓	DRILL 48XD3 WCM 080412	3.367
WCM.D3 049 ISO	✓	✓	DRILL 49XD3 WCM 080412	3.494
WCM.D3 050 ISO	✓	✓	DRILL 50XD3 WCM 080412	3.738

DRILL WCM. D4



DRILL WCM. D5



Lütfen Sipariş vermeden önce stok durumunu sorunuz.
Please ask before ordering, stock status.

KOD	Stok Stock	Inter Cooland	Kesici Uç Uyumluluğu / Insert Suitability		FİYAT PRICE
			WCM.		TL
WCM.D4 015,5 ISO	✓	✓	DRILL 15,5XD4 WCM 030208		2.629
WCM.D4 016 ISO	✓	✓	DRILL 16XD4 WCM 030208		2.629
WCM.D4 017 ISO	✓	✓	DRILL 17XD4 WCM 030208		2.629
WCM.D4 017,5 ISO	✓	✓	DRILL 17,5XD4 WCM 030208		2.629
WCM.D4 018 ISO	✓	✓	DRILL 18XD4 WCM 030208		2.629
WCM.D4 019 ISO	✓	✓	DRILL 19XD4 WCM 030208		2.629
WCM.D4 019,5 ISO	✓	✓	DRILL 19,5XD4 WCM.030208		2.629
WCM.D4 020 ISO	✓	✓	DRILL 20XD4 WCM 040208		2.754
WCM.D4 021 ISO	✓	✓	DRILL 21XD4 WCM 040208		2.754
WCM.D4 022 ISO	✓	✓	DRILL 22XD4 WCM 040208		2.754
WCM.D4 023 ISO	✓	✓	DRILL 23XD4 WCM 040208		2.754
WCM.D4 023,5 ISO	✓	✓	DRILL 23,5XD4 WCM 040208		2.754
WCM.D4 024 ISO	✓	✓	DRILL 24XD4 WCM 050308		2.875
WCM.D4 025 ISO	✓	✓	DRILL 25XD4 WCM 050308		2.875
WCM.D4 025,5 ISO	✓	✓	DRILL 25,5XD4 WCM 050308		2.875
WCM.D4 026 ISO	✓	✓	DRILL 26XD4 WCM 050308		2.875
WCM.D4 027 ISO	✓	✓	DRILL 27XD4 WCM 050308		2.875
WCM.D4 027,5 ISO	✓	✓	DRILL 27,5XD4 WCM 050308		2.875
WCM.D4 028 ISO	✓	✓	DRILL 28XD4 WCM 050308		2.875
WCM.D4 029 ISO	✓	✓	DRILL 29XD4 WCM 050308		2.875
WCM.D4 030 ISO	✓	✓	DRILL 30XD4 WCM 06T308		3.120
WCM.D4 031 ISO	✓	✓	DRILL 31XD4 WCM 06T308		3.120
WCM.D4 031,5 ISO	✓	✓	DRILL 31,5XD4 WCM 06T308		3.120
WCM.D4 032 ISO	✓	✓	DRILL 32XD4 WCM 06T308		3.120
WCM.D4 033 ISO	✓	✓	DRILL 33XD4 WCM 06T308		3.120
WCM.D4 033,5 ISO	✓	✓	DRILL 33,5XD4 WCM 06T308		3.120
WCM.D4 034 ISO	✓	✓	DRILL 34XD4 WCM 06T308		3.120
WCM.D4 035 ISO	✓	✓	DRILL 35XD4 WCM 06T308		3.120
WCM.D4 036 ISO	✓	✓	DRILL 36XD4 WCM 06T308		3.120
WCM.D4 037 ISO	✓	✓	DRILL 37XD4 WCM 06T308		3.120
WCM.D4 038 ISO	✓	✓	DRILL 38XD4 WCM 06T308		3.120
WCM.D4 038,5 ISO	✓	✓	DRILL 38,5XD4 WCM 06T308		3.120
WCM.D4 039 ISO	✓	✓	DRILL 39XD4 WCM 06T308		3.120
WCM.D4 040 ISO	✓	✓	DRILL 40XD4 WCM 06T308		3.120
WCM.D4 041 ISO	✓	✓	DRILL 41XD4 WCM 06T308		3.367
WCM.D4 041,5 ISO	✓	✓	DRILL 41,5XD4 WCM 06T308		3.367
WCM.D4 042 ISO	✓	✓	DRILL 42XD4 WCM 06T308		3.367
WCM.D4 043 ISO	✓	✓	DRILL 43XD4 WCM 06T308		3.367
WCM.D4 044 ISO	✓	✓	DRILL 44XD4 WCM 06T308		3.367
WCM.D4 045 ISO	X	✓	DRILL 45XD4 WCM 080412		3.530
WCM.D4 046 ISO	X	✓	DRILL 46XD4 WCM 080412		3.738
WCM.D4 047 ISO	X	✓	DRILL 47XD4 WCM 080412		3.985
WCM.D4 048 ISO	X	✓	DRILL 48XD4 WCM 080412		4.105
WCM.D4 049 ISO	X	✓	DRILL 49XD4 WCM 080412		4.516
WCM.D4 050 ISO	X	✓	DRILL 50XD4 WCM 080412		4.724

KOD	Stok Stock	Inter Cooland	Kesici Uç Uyumluluğu / Insert Suitability		FİYAT PRICE
			WCM.		TL
WCM.D5 016 ISO	✓	✓	DRILL 16XD5 WCM 030208		3.328
WCM.D5 017 ISO	✓	✓	DRILL 17XD5 WCM 030208		3.328
WCM.D5 018 ISO	✓	✓	DRILL 18XD5 WCM 030208		3.328
WCM.D5 019 ISO	✓	✓	DRILL 19XD5 WCM 030208		3.494
WCM.D5 020 ISO	✓	✓	DRILL 20XD5 WCM 040208		3.494
WCM.D5 021 ISO	✓	✓	DRILL 21XD5 WCM 040208		3.494
WCM.D5 022 ISO	✓	✓	DRILL 22XD5 WCM 040208		3.494
WCM.D5 023 ISO	✓	✓	DRILL 23XD5 WCM 040208		3.781
WCM.D5 024 ISO	✓	✓	DRILL 24XD5 WCM 050308		3.781
WCM.D5 025 ISO	✓	✓	DRILL 25XD5 WCM 050308		3.781
WCM.D5 026 ISO	✓	✓	DRILL 26XD5 WCM 050308		3.781
WCM.D5 027 ISO	✓	✓	DRILL 27XD5 WCM 050308		3.781
WCM.D5 028 ISO	✓	✓	DRILL 28XD5 WCM 050308		3.781
WCM.D5 029 ISO	✓	✓	DRILL 29XD5 WCM 050308		3.781
WCM.D5 030 ISO	✓	✓	DRILL 30XD5 WCM 06T308		3.902

L: Sol / Left

R: Sağ / Right

✓ Stokta / In Stock

X Stokta Yok / Non Stock

DRILL SP.. D2



KOD	Stok Stock	Inter Cooland	Kesici Uç Uyumluluğu / Insert Suitability	FIYAT PRICE
			TGTC / PLBT / ZCC / KLP	TL
SP..D2 012,5 ISO	✓	✓	DRILL 12,5XD2 SP.050204	1.991
SP..D2 013 ISO	✓	✓	DRILL 13XD2 SP.050204	1.991
SP..D2 013,5 ISO	✓	✓	DRILL 13,5XD2 SP.050204	1.991
SP..D2 014 ISO	✓	✓	DRILL 14XD2 SP.050204	1.991
SP..D2 014,5 ISO	✓	✓	DRILL 14,5XD2 SP.060204	1.991
SP..D2 015 ISO	✓	✓	DRILL 15XD2 SP.050204	1.991
SP..D2 015,5 ISO	✓	✓	DRILL 15,5XD2 SP.060204	1.991
SP..D2 016 ISO	✓	✓	DRILL 16XD2 SP.060204	1.991
SP..D2 016,5 ISO	✓	✓	DRILL 16,5XD2 SP.060204	1.991
SP..D2 017 ISO	✓	✓	DRILL 17XD2 SP.060204	1.991
SP..D2 017,5 ISO	✓	✓	DRILL 17,5XD2 SP.060204	1.991
SP..D2 018 ISO	✓	✓	DRILL 18XD2 SP.060204	1.991
SP..D2 018,5 ISO	✓	✓	DRILL 18,5XD2 SP.060204	1.991
SP..D2 019 ISO	✓	✓	DRILL 19XD2 SP.060204	1.991
SP..D2 019,5 ISO	✓	✓	DRILL 19,5XD2 SP.060204	1.991
SP..D2 020 ISO	✓	✓	DRILL 20XD2 SP.060204	2.050
SP..D2 020,5 ISO	✓	✓	DRILL 20,5XD2 SP.060204	2.050
SP..D2 021 ISO	✓	✓	DRILL 21XD2 SP.060204	2.050
SP..D2 021,5 ISO	✓	✓	DRILL 21,5XD2 SP.060204	2.050
SP..D2 022 ISO	✓	✓	DRILL 22XD2 SP.07T308	2.050
SP..D2 022,5 ISO	✓	✓	DRILL 22,5XD2 SP.07T308	2.050
SP..D2 023 ISO	✓	✓	DRILL 23XD2 SP.07T308	2.050
SP..D2 023,5 ISO	✓	✓	DRILL 23,5XD2 SP.07T308	2.050
SP..D2 024 ISO	✓	✓	DRILL 24XD2 SP.07T308	2.050
SP..D2 024,5 ISO	✓	✓	DRILL 24,5XD2 SP.07T308	2.050
SP..D2 025 ISO	✓	✓	DRILL 25XD2 SP.07T308	2.050
SP..D2 025,5 ISO	✓	✓	DRILL 25,5XD2 SP.07T308	2.050
SP..D2 026 ISO	✓	✓	DRILL 26XD2 SP.07T308	2.050
SP..D2 026,5 ISO	✓	✓	DRILL 26,5XD2 SP.07T308	2.050
SP..D2 027 ISO	✓	✓	DRILL 27XD2 SP.07T308	2.050
SP..D2 027,5 ISO	✓	✓	DRILL 27,5XD2 SP.090408	2.177
SP..D2 028 ISO	✓	✓	DRILL 28XD2 SP.090408	2.177
SP..D2 028,5 ISO	✓	✓	DRILL 28,5XD2 SP.090408	2.177
SP..D2 029 ISO	✓	✓	DRILL 29XD2 SP.090408	2.177
SP..D2 029,5 ISO	✓	✓	DRILL 29,5XD2 SP.090408	2.177
SP..D2 030 ISO	✓	✓	DRILL 30XD2 SP.090408	2.177
SP..D2 031 ISO	✓	✓	DRILL 31XD2 SP.090408	2.177
SP..D2 032 ISO	✓	✓	DRILL 32XD2 SP.090408	2.177
SP..D2 033 ISO	✓	✓	DRILL 33XD2 SP.090408	2.464
SP..D2 034 ISO	✓	✓	DRILL 34XD2 SP.110408	2.464
SP..D2 035 ISO	✓	✓	DRILL 35XD2 SP.110408	2.464
SP..D2 036 ISO	✓	✓	DRILL 36XD2 SP.110408	2.464
SP..D2 037 ISO	✓	✓	DRILL 37XD2 SP.110408	2.464
SP..D2 038 ISO	✓	✓	DRILL 38XD2 SP.110408	2.464
SP..D2 039 ISO	✓	✓	DRILL 39XD2 SP.110408	2.464
SP..D2 040 ISO	✓	✓	DRILL 40XD2 SP.110408	2.464
SP..D2 041 ISO	✓	✓	DRILL 41XD2 SP.110408	2.545
SP..D2 042 ISO	✓	✓	DRILL 42XD2 SP.140512	2.545
SP..D2 42,5 ISO	✓	✓	DRILL 42,5XD2 SP.140512	2.545
SP..D2 043 ISO	✓	✓	DRILL 43XD2 SP.140512	2.545
SP..D2 044 ISO	✓	✓	DRILL 44XD2 SP.140512	2.545
SP..D2 045 ISO	✓	✓	DRILL 45XD2 SP.140512	2.670
SP..D2 046 ISO	✓	✓	DRILL 46XD2 SP.140512	2.875
SP..D2 047 ISO	✓	✓	DRILL 47XD2 SP.140512	3.081
SP..D2 048 ISO	✓	✓	DRILL 48XD2 SP.140512	3.204
SP..D2 049 ISO	✓	✓	DRILL 49XD2 SP.140512	3.328
SP..D2 050 ISO	✓	✓	DRILL 50XD2 SP.140512	3.494

DRILL SP.. D3



KOD	Stok Stock	Inter Cooland	Kesici Uç Uyumluluğu / Insert Suitability	FIYAT PRICE
			TGTC / PLBT / ZCC / KLP	TL
SP..D3 012,5 ISO	✓	✓	DRILL 12,5XD3 SP.050204	2.134
SP..D3 013 ISO	✓	✓	DRILL 13XD3 SP.050204	2.134
SP..D3 013,5 ISO	✓	✓	DRILL 13,5XD3 SP.050204	2.134
SP..D3 014 ISO	✓	✓	DRILL 14XD3 SP.050204	2.134
SP..D3 014,5 ISO	✓	✓	DRILL 14,5XD3 SP.050204	2.134
SP..D3 015 ISO	✓	✓	DRILL 15XD3 SP.050204	2.134
SP..D3 015,5 ISO	✓	✓	DRILL 15,5XD3 SP.050204	2.134
SP..D3 016 ISO	✓	✓	DRILL 16XD3 SP.060204	2.134
SP..D3 016,5 ISO	✓	✓	DRILL 16,5XD3 SP.060204	2.134
SP..D3 017 ISO	✓	✓	DRILL 17XD3 SP.060204	2.134
SP..D3 017,5 ISO	✓	✓	DRILL 17,5XD3 SP.060204	2.134
SP..D3 018 ISO	✓	✓	DRILL 18XD3 SP.060204	2.134
SP..D3 018,5 ISO	✓	✓	DRILL 18,5XD3 SP.060204	2.134
SP..D3 019 ISO	✓	✓	DRILL 19XD3 SP.060204	2.134
SP..D3 019,5 ISO	✓	✓	DRILL 19,5XD3 SP.060204	2.134
SP..D3 020 ISO	✓	✓	DRILL 20XD3 SP.060204	2.260
SP..D3 020,5 ISO	✓	✓	DRILL 20,5XD3 SP.060204	2.260
SP..D3 021 ISO	✓	✓	DRILL 21XD3 SP.060204	2.260
SP..D3 021,5 ISO	✓	✓	DRILL 21,5XD3 SP.060204	2.260
SP..D3 022 ISO	✓	✓	DRILL 22XD3 SP.07T308	2.260
SP..D3 022,5 ISO	✓	✓	DRILL 22,5XD3 SP.07T308	2.260
SP..D3 023 ISO	✓	✓	DRILL 23XD3 SP.07T308	2.260
SP..D3 023,5 ISO	✓	✓	DRILL 23,5XD3 SP.07T308	2.260
SP..D3 024 ISO	✓	✓	DRILL 24XD3 SP.07T308	2.301
SP..D3 024,5 ISO	✓	✓	DRILL 24,5XD3 SP.07T308	2.301
SP..D3 025 ISO	✓	✓	DRILL 25XD3 SP.07T308	2.301
SP..D3 025,5 ISO	✓	✓	DRILL 25,5XD3 SP.07T308	2.301
SP..D3 026 ISO	✓	✓	DRILL 26XD3 SP.07T308	2.301
SP..D3 026,5 ISO	✓	✓	DRILL 26,5XD3 SP.07T308	2.301
SP..D3 027 ISO	✓	✓	DRILL 27XD3 SP.07T308	2.301
SP..D3 027,5 ISO	✓	✓	DRILL 27,5XD3 SP.07T308	2.301
SP..D3 028 ISO	✓	✓	DRILL 28XD3 SP.090408	2.301
SP..D3 028,5 ISO	✓	✓	DRILL 28,5XD3 SP.090408	2.301
SP..D3 029 ISO	✓	✓	DRILL 29XD3 SP.090408	2.301
SP..D3 029,5 ISO	✓	✓	DRILL 29,5XD3 SP.090408	2.301
SP..D3 030 ISO	✓	✓	DRILL 30XD3 SP.090408	2.505
SP..D3 031 ISO	✓	✓	DRILL 31XD3 SP.090408	2.505
SP..D3 032 ISO	✓	✓	DRILL 32XD3 SP.090408	2.505
SP..D3 033 ISO	✓	✓	DRILL 33XD3 SP.090408	2.505
SP..D3 034 ISO	✓	✓	DRILL 34XD3 SP.110408	2.505
SP..D3 035 ISO	✓	✓	DRILL 35XD3 SP.110408	2.505
SP..D3 036 ISO	✓	✓	DRILL 36XD3 SP.110408	2.505
SP..D3 037 ISO	✓	✓	DRILL 37XD3 SP.110408	2.505
SP..D3 038 ISO	✓	✓	DRILL 38XD3 SP.110408	2.505
SP..D3 038,5 ISO	✓	✓	DRILL 38,5XD3 SP.110408	2.505
SP..D3 039 ISO	✓	✓	DRILL 39XD3 SP.110408	2.505
SP..D3 040 ISO	✓	✓	DRILL 40XD3 SP.110408	2.505
SP..D3 041 ISO	✓	✓	DRILL 41XD3 SP.110408	2.792
SP..D3 041,5 ISO	✓	✓	DRILL 41,5XD3 SP.110408	2.792
SP..D3 042 ISO	✓	✓	DRILL 42XD3 SP.140512	2.792
SP..D3 043 ISO	✓	✓	DRILL 43XD3 SP.140512	2.792
SP..D3 044 ISO	✓	✓	DRILL 44XD3 SP.140512	2.792
SP..D3 045 ISO	✓	✓	DRILL 45XD3 SP.140512	2.917
SP..D3 046 ISO	✓	✓	DRILL 46XD3 SP.140512	3.081
SP..D3 047 ISO	✓	✓	DRILL 47XD3 SP.140512	3.204
SP..D3 048 ISO	✓	✓	DRILL 48XD3 SP.140512	3.367
SP..D3 049 ISO	✓	✓	DRILL 49XD3 SP.140512	3.494
SP..D3 050 ISO	✓	✓	DRILL 50XD3 SP.140512	3.738
SP..D3 050,5 ISO	✗	✓	DRILL 50,5XD3 SP.140512	3.818

DRILL SP.. D4



KOD	Stok Stock	Infer Cooland	Kesici Uç Uyumluluğu / Insert Suitability	FIYAT PRICE
			TGTC / PLBT / ZCC / KLP	TL
SP..D4 013 ISO	✓	✓	DRILL 13XD4 SP.050204	2.629
SP..D4 014 ISO	✓	✓	DRILL 14XD4 SP.050204	2.629
SP..D4 014,5 ISO	✓	✓	DRILL 14,5XD4 SP.050204	2.629
SP..D4 015 ISO	✓	✓	DRILL 15XD4 SP.050204	2.629
SP..D4 015,5 ISO	✓	✓	DRILL 15,5XD4 SP.050204	2.629
SP..D4 016 ISO	✓	✓	DRILL 16XD4 SP.060204	2.629
SP..D4 017 ISO	✓	✓	DRILL 17XD4 SP.060204	2.629
SP..D4 017,5 ISO	✓	✓	DRILL 17,5XD4 SP.060204	2.629
SP..D4 018 ISO	✓	✓	DRILL 18XD4 SP.060204	2.629
SP..D4 019 ISO	✓	✓	DRILL 19XD4 SP.060204	2.629
SP..D4 019,5 ISO	✓	✓	DRILL 19,5XD4 SP.060204	2.629
SP..D4 020 ISO	✓	✓	DRILL 20XD4 SP.060204	2.754
SP..D4 021 ISO	✓	✓	DRILL 21XD4 SP.060204	2.754
SP..D4 022 ISO	✓	✓	DRILL 22XD4 SP.070204	2.754
SP..D4 023 ISO	✓	✓	DRILL 23XD4 SP.070204	2.754
SP..D4 023,5 ISO	✓	✓	DRILL 23,5XD4 SP.07T308	2.754
SP..D4 024 ISO	✓	✓	DRILL 24XD4 SP.07T308	2.875
SP..D4 024,5 ISO	✓	✓	DRILL 24,5XD4 SP.07T308	2.875
SP..D4 025 ISO	✓	✓	DRILL 25XD4 SP.07T308	2.875
SP..D4 026 ISO	✓	✓	DRILL 26XD4 SP.07T308	2.875
SP..D4 027 ISO	✓	✓	DRILL 27XD4 SP.07T308	2.875
SP..D4 027,5 ISO	✓	✓	DRILL 27,5XD4 SP.07T308	2.875
SP..D4 028 ISO	✓	✓	DRILL 28XD4 SP.090408	2.875
SP..D4 029 ISO	✓	✓	DRILL 29XD4 SP.090408	2.875
SP..D4 030 ISO	✓	✓	DRILL 30XD4 SP.090408	3.120
SP..D4 031 ISO	✓	✓	DRILL 31XD4 SP.090408	3.120
SP..D4 032 ISO	✓	✓	DRILL 32XD4 SP.090408	3.120
SP..D4 033 ISO	✓	✓	DRILL 33XD4 SP.090408	3.120
SP..D4 033,5 ISO	✓	✓	DRILL 33,5XD4 SP.090408	3.120
SP..D4 034 ISO	✓	✓	DRILL 34XD4 SP.110408	3.120
SP..D4 035 ISO	✓	✓	DRILL 35XD4 SP.110408	3.120
SP..D4 036 ISO	✓	✓	DRILL 36XD4 SP.110408	3.120
SP..D4 037 ISO	✓	✓	DRILL 37XD4 SP.110408	3.120
SP..D4 038 ISO	✓	✓	DRILL 38XD4 SP.110408	3.120
SP..D4 038,5 ISO	✓	✓	DRILL 38,5XD4 SP.110408	3.120
SP..D4 039 ISO	✓	✓	DRILL 39XD4 SP.110408	3.120
SP..D4 039,5 ISO	✓	✓	DRILL 39,5XD4 SP.110408	3.120
SP..D4 040 ISO	✓	✓	DRILL 40XD4 SP.110408	3.120
SP..D4 041 ISO	✓	✓	DRILL 41XD4 SP.110408	3.367
SP..D4 042 ISO	x	✓	DRILL 42XD4 SP.140512	3.367
SP..D4 043 ISO	x	✓	DRILL 43XD4 SP.140512	3.367
SP..D4 044 ISO	x	✓	DRILL 44XD4 SP.140512	3.367
SP..D4 045 ISO	x	✓	DRILL 45XD4 SP.140512	3.367
SP..D4 046 ISO	x	✓	DRILL 46XD4 SP.140512	3.530
SP..D4 047 ISO	x	✓	DRILL 47XD4 SP.140512	3.738
SP..D4 048 ISO	x	✓	DRILL 48XD4 SP.140512	3.985
SP..D4 049 ISO	x	✓	DRILL 49XD4 SP.140512	4.105
SP..D4 050 ISO	x	✓	DRILL 50XD4 SP.140512	4.516

DRILL SP.. D5



KOD	Stok Stock	Inter Cooland	Kesici Uç Uyumluluğu / Insert Suitability	FİYAT PRICE
			TGTC / PLBT / ZCC / KLP	TL
SP..D5 016 ISO	✓	✓	DRILL 16XD5 SP.060204	3.204
SP..D5 017 ISO	✓	✓	DRILL 17XD5 SP.060204	3.204
SP..D5 018 ISO	✓	✓	DRILL 18XD5 SP.060204	3.204
SP..D5 019 ISO	✓	✓	DRILL 19XD5 SP.060204	3.204
SP..D5 020 ISO	✓	✓	DRILL 20XD5 SP.060204	3.367
SP..D5 021 ISO	✓	✓	DRILL 21XD5 SP.060204	3.367
SP..D5 022 ISO	✓	✓	DRILL 22XD5 SP.070204	3.367
SP..D5 023 ISO	✓	✓	DRILL 23XD5 SP.070204	3.530
SP..D5 024 ISO	✓	✓	DRILL 24XD5 SP.07T308	3.530
SP..D5 025 ISO	✓	✓	DRILL 25XD5 SP.07T308	3.530
SP..D5 026 ISO	✓	✓	DRILL 26XD5 SP.07T308	3.530
SP..D5 027 ISO	✓	✓	DRILL 27XD5 SP.07T308	3.530
SP..D5 028 ISO	✓	✓	DRILL 28XD5 SP.090408	3.697
SP..D5 029 ISO	✓	✓	DRILL 29XD5 SP.090408	3.697
SP..D5 030 ISO	✓	✓	DRILL 30XD5 SP.090408	3.697

DRILL XOMT-SPMT D2



KOD	Stok Stock	Inter Cooland	Kesici Uç Uyumluluğu / Insert Suitability	FİYAT PRICE
			XO*T-SP*T	TL
XOSP D2 016 ISO	✓	✓	DRILL 16XD2 SPMT 050204-XOMT 050204	2.013
XOSP D2 017 ISO	✓	✓	DRILL 17XD2 SPMT 060205-XOMT 060204	2.013
XOSP D2 018 ISO	✓	✓	DRILL 18XD2 SPMT 060205-XOMT 060204	2.013
XOSP D2 019 ISO	✓	✓	DRILL 19XD2 SPMT 060205-XOMT 060204	2.013
XOSP D2 020 ISO	✓	✓	DRILL 20XD2 SPMT 07T208-XOMT 07T205	2.094
XOSP D2 021 ISO	✓	✓	DRILL 21XD2 SPMT 07T208-XOMT 07T205	2.094
XOSP D2 022 ISO	✓	✓	DRILL 22XD2 SPMT 07T208-XOMT 07T205	2.094
XOSP D2 023 ISO	✓	✓	DRILL 23XD2 SPMT 07T208-XOMT 07T205	2.094
XOSP D2 024 ISO	✓	✓	DRILL 24XD2 SPMT 090308-XOMT 090305	2.177
XOSP D2 025 ISO	✓	✓	DRILL 25XD2 SPMT 090308-XOMT 090305	2.177
XOSP D2 026 ISO	✓	✓	DRILL 26XD2 SPMT 090308-XOMT 090305	2.177
XOSP D2 027 ISO	✓	✓	DRILL 27XD2 SPMT 090308-XOMT 090305	2.177
XOSP D2 028 ISO	✓	✓	DRILL 28XD2 SPMT 090308-XOMT 090305	2.177
XOSP D2 029 ISO	✓	✓	DRILL 29XD2 SPMT 090308-XOMT 090305	2.177
XOSP D2 030 ISO	✓	✓	DRILL 30XD2 SPMT 11T308-XOMT 11T306	2.421
XOSP D2 031 ISO	✓	✓	DRILL 31XD2 SPMT 11T308-XOMT 11T306	2.421
XOSP D2 032 ISO	✓	✓	DRILL 32XD2 SPMT 11T308-XOMT 11T306	2.421
XOSP D2 033 ISO	✓	✓	DRILL 33XD2 SPMT 11T308-XOMT 11T306	2.421
XOSP D2 034 ISO	✓	✓	DRILL 34XD2 SPMT 11T308-XOMT 11T306	2.421
XOSP D2 035 ISO	✓	✓	DRILL 35XD2 SPMT 11T308-XOMT11T306	2.421

DRILL XOMT-SPMT D3



DRILL XOMT-SPMT D4



DRILL QCMT D2



KOD	Stok Stock	Inter Cooland	Kesici Uç Uyumluluğu / Insert Suitability		FİYAT PRICE
			XO*T-SP*T		
				TL	
XOSP D3 016 ISO	✓	✓	DRILL 16XD3 SPMT 050204-XOMT 050204		2.260
XOSP D3 017 ISO	✓	✓	DRILL 17XD3 SPMT 060205-XOMT 060204		2.260
XOSP D3 018 ISO	✓	✓	DRILL 18XD3 SPMT 060205-XOMT 060204		2.260
XOSP D3 019 ISO	✓	✓	DRILL 19XD3 SPMT 060205-XOMT 060204		2.260
XOSP D3 020 ISO	✓	✓	DRILL 20XD3 SPMT 07T208-XOMT 07T205		2.345
XOSP D3 021 ISO	✓	✓	DRILL 21XD3 SPMT 07T208-XOMT 07T205		2.345
XOSP D3 022 ISO	✓	✓	DRILL 22XD3 SPMT 07T208-XOMT 07T205		2.345
XOSP D3 023 ISO	✓	✓	DRILL 23XD3 SPMT 07T208-XOMT 07T205		2.345
XOSP D3 024 ISO	✓	✓	DRILL 24XD3 SPMT 090308-XOMT 090305		2.345
XOSP D3 025 ISO	✓	✓	DRILL 25XD3 SPMT 090308-XOMT 090305		2.421
XOSP D3 026 ISO	✓	✓	DRILL 26XD3 SPMT 090308-XOMT 090305		2.421
XOSP D3 027 ISO	✓	✓	DRILL 27XD3 SPMT 090308-XOMT 090305		2.421
XOSP D3 028 ISO	✓	✓	DRILL 28XD3 SPMT 090308-XOMT 090305		2.421
XOSP D3 029 ISO	✓	✓	DRILL 29XD3 SPMT 090308-XOMT 090305		2.421
XOSP D3 030 ISO	✓	✓	DRILL 30XD3 SPMT 11T308-XOMT 11T306		2.670
XOSP D3 031 ISO	✓	✓	DRILL 31XD3 SPMT 11T308-XOMT 11T306		2.670
XOSP D3 032 ISO	✓	✓	DRILL 32XD3 SPMT 11T308-XOMT 11T306		2.670
XOSP D3 033 ISO	✓	✓	DRILL 33XD3 SPMT 11T308-XOMT 11T306		2.670
XOSP D3 034 ISO	✓	✓	DRILL 34XD3 SPMT 11T308-XOMT 11T306		2.670
XOSP D3 035 ISO	✓	✓	DRILL 35XD3 SPMT 11T308-XOMT 11T306		2.670

KOD	Stok Stock	Inter Cooland	Kesici Uç Uyumluluğu / Insert Suitability		FİYAT PRICE
			XO*T-SP*T		
				TL	
XOSP D4 016 ISO	✓	✓	DRILL 16XD4 SPMT 050204-XOMT 050204		2.956
XOSP D4 017 ISO	✓	✓	DRILL 17XD4 SPMT 060205-XOMT 060204		2.956
XOSP D4 018 ISO	✓	✓	DRILL 18XD4 SPMT 060205-XOMT 060204		2.956
XOSP D4 019 ISO	✓	✓	DRILL 19XD4 SPMT 060205-XOMT 060204		2.956
XOSP D4 020 ISO	✓	✓	DRILL 20XD4 SPMT 07T208-XOMT 07T205		2.956
XOSP D4 021 ISO	✓	✓	DRILL 21XD4 SPMT 07T208-XOMT 07T205		3.040
XOSP D4 022 ISO	✓	✓	DRILL 22XD4 SPMT 07T208-XOMT 07T205		3.040
XOSP D4 023 ISO	✓	✓	DRILL 23XD4 SPMT 07T208-XOMT 07T205		3.040
XOSP D4 024 ISO	✓	✓	DRILL 24XD4 SPMT 090308-XOMT 090305		3.040
XOSP D4 025 ISO	✓	✓	DRILL 25XD4 SPMT 090308-XOMT 090305		3.040
XOSP D4 026 ISO	✓	✓	DRILL 26XD4 SPMT 090308-XOMT 090305		3.328
XOSP D4 027 ISO	✓	✓	DRILL 27XD4 SPMT 090308-XOMT 090305		3.328
XOSP D4 028 ISO	✓	✓	DRILL 28XD4 SPMT 090308-XOMT 090305		3.328
XOSP D4 029 ISO	✓	✓	DRILL 29XD4 SPMT 090308-XOMT 090305		3.328
XOSP D4 030 ISO	✓	✓	DRILL 30XD4 SPMT 11T308-XOMT 11T306		3.494
XOSP D4 031 ISO	✓	✓	DRILL 31XD4 SPMT 11T308-XOMT 11T306		3.494
XOSP D4 032 ISO	✓	✓	DRILL 32XD4 SPMT 11T308-XOMT 11T306		3.494
XOSP D4 033 ISO	✓	✓	DRILL 33XD4 SPMT 11T308-XOMT 11T306		3.494
XOSP D4 034 ISO	✓	✓	DRILL 34XD4 SPMT 11T308-XOMT 11T306		3.494
XOSP D4 035 ISO	✓	✓	DRILL 35XD4 SPMT 11T308-XOMT 11T306		3.494

KOD	Stok Stock	Inter Cooland	Kesici Uç Uyumluluğu / Insert Suitability		FİYAT PRICE
			QCMT - KRLY		
				TL	
MBC 002 ECOCUT KRLY	✓	✓	MBC 10X2,25D-R QCMT		1.550
MBC 003 ECOCUT KRLY	✓	✓	MBC 12X2,25D-R QCMT		1.650
MBC 004 ECOCUT KRLY	✓	✓	MBC 14X2,25D-R QCMT		1.700
MBC 005 ECOCUT KRLY	✓	✓	MBC 16X2,25D-R QCMT		1.750
MBC 006 ECOCUT KRLY	✓	✓	MBC 18X2,25D-R QCMT		1.800
MBC 007 ECOCUT KRLY	✓	✓	MBC 20X2,25D-R QCMT		1.850
MBC 008 ECOCUT KRLY	✓	✓	MBC 25X2,25D-R QCMT		2.100

PASO KATERLERİ
STEP CUTTING TOOLS



KOD	Stok / Stock	Kesici Uç Uyumluluğu / Insert Suitability	FİYAT PRICE
		TORNA KATERİ	TL
HSS PS 001 ISO	✓	6 / 8 HSS TORNA KATERİ	768
HSS PS 002 ISO	✓	8 / 10 HSS TORNA KATERİ	768
HSS PS 003 ISO	✓	10 / 12 HSS TORNA KATERİ	768
HSS PS 004 ISO	✓	12 / 14 HSS TORNA KATERİ	768

KESME KATERLERİ
CUTTING TOOLS



KOD	Stok / Stock	Kesici Uç Uyumluluğu / Insert Suitability	FİYAT PRICE
		TORNA KATERİ	TL
HSS KS 001 ISO	✓	HSS KESME 1/2	768
HSS KS 002 ISO	✓	HSS KESME 5/8	768
HSS KS 003 ISO	✓	HSS KESME 3/4	768
HSS KS 004 ISO	✓	HSS KESME 7/8	850
HSS KS 005 ISO	✓	HSS KESME 1"	850

PUNTA KATERİ
PUNTA TOOL



KOD	Stok / Stock	Kesici Uç Uyumluluğu / Insert Suitability	FİYAT PRICE
		TORNA KATERİ	TL
CNC PUNTA 001	✓	20X20 CNC PUNTA 2,5X6,3	1.039
CNC PUNTA 002	✓	20X20 CNC PUNTA 3,15X8	1.039
CNC PUNTA 004	✓	25X25 CNC PUNTA 2,5X6,3	1.115
CNC PUNTA 005	✓	25X25 CNC PUNTA 3,15X8	1.115

TIRTIR TEKLİ
SINGLE TOOLS



KOD	Stok / Stock	Kesici Uç Uyumluluğu / Insert Suitability	FIYAT PRICE
		TIRTIR KATER	TL
TIR-TIR 001	x	TIRTIR 10X10 4K-4P	768
TIR-TIR 003	x	TIRTIR 12X12 6K-4P	768
TIR-TIR 004	x	TIRTIR 12X12 6K-6P	768
TIR-TIR 007	✓	TIRTIR 20X20 8K	894
TIR-TIR 008	✓	TIRTIR 20X20 10K	894
TIR-TIR 009	✓	TIRTIR 25X25 8K	1.023
TIR-TIR 010	✓	TIRTIR 25X25 10K	1.023
TIR-TIR 015	✓	TIRTIR 16X16 6K-4P	768
TIR-TIR 016	✓	TIRTIR 16X16 6K-6P	768
TIR-TIR 017	✓	TIRTIR 16X16 8K-6P	768
TIR-TIR 018	✓	TIRTIR 16X16 10K-6P	768
TIR-TIR 019	✓	CNC TIRTIR 25X25 10K	978
TIR-TIR 020	✓	CNC TIRTIR 20X20 10K	850
TIR-TIR 021	✓	CNC TIRTIR 16X16 8K R45	768

TIRTIR ÇİFTLİ
DOUBLE TOOLS



KOD	Stok / Stock	Kesici Uç Uyumluluğu / Insert Suitability	FIYAT PRICE
		ÇİFTLİ TIRTIR	TL
TIR TIR Ç 001	✓	ÇİFTLİ TIRTIR 22X22 10K	1.105

T SOMUN

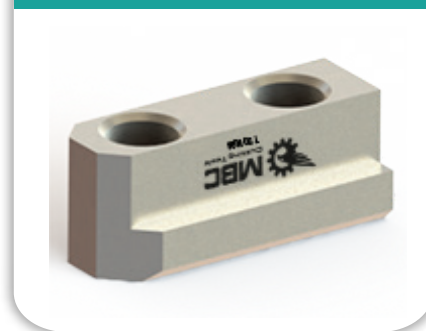

KOD	Stok / Stock	Kesici Uç Uyumluluğu / Insert Suitability	FIYAT PRICE
		T SOMUN	TL
TS6 001 6" T-SOMUN	✓	TS6 001 6" T-SOMUN	1.071
TS6 002 8" T-SOMUN	✓	TS6 002 8" T-SOMUN	1.404
TS6 003 10" T-SOMUN	✓	TS6 003 10" T-SOMUN	1.597
TS6 004 12" T-SOMUN	✓	TS6 004 12" T-SOMUN	1.738

STANDART YUMUŞAK AYAK
STANDARD SOFT JAWS



KOD	Stok / Stock	Kesici Uç Uyumluluğu / Insert Suitability	FIYAT PRICE
		SYA	TL
SYA 001	✓	8" STANDART YUMUŞAK AYAK	912
SYA 002	✓	10" STANDART YUMUŞAK AYAK	1.036
SYA 003	✓	6" STANDART YUMUŞAK AYAK	825
SYA 004	✓	12" STANDART YUMUŞAK AYAK	1.352

SİVRİ STANDART YUMUŞAK AYAK
POINTED STANDARD SOFT JAWS



KOD	Stok / Stock	Kesici Uç Uyumluluğu / Insert Suitability	FIYAT PRICE
		SSYA	TL
SSYA 001	✓	8" SİVRİ STANDART YUMUŞAK AYAK	912
SSYA 002	✓	10" SİVRİ STANDART YUMUŞAK AYAK	1.036

YÜKSEK YUMUŞAK AYAK
HIGH SOFT JAWS





KOD	Stok / Stock	Kesici Uç Uyumluluğu / Insert Suitability	FIYAT PRICE
		YYA	TL
YYA 001	✓	8" YÜKSEK YUMUŞAK AYAK	1.439
YYA 002	✓	10" YÜKSEK YUMUŞAK AYAK	1.790
YYA 003	✓	6" YÜKSEK YUMUŞAK AYAK	1.246
YYA 004	✓	12" YÜKSEK YUMUŞAK AYAK	2.299

ÇİVATALAR - SCREWS

BASKI ÇİVATALARI		FIYAT PRICE TL
	M5X23 A3	39
	M6X27 A3	39

ALTLIK VİDALARI		FIYAT PRICE TL
	M3X10	23
	M4X10	23
	M5X10	23
	M6X10	23

BUKSE VİDA		FIYAT PRICE TL
	M5X0.5X3.5	51
	M6X0.75X4	51

TORX VİDALARI		FIYAT PRICE TL
	M1.8X4.2X2.4	72
	M2X4	23
	M2X5	23
	M2.2X5	23
	M2.2X6	23
	M2.5X5	23
	M2.5X6	23
	M2.5X7	23
	M2.5X10	23
	M3X7	23
	M3X8	23
	M3X8X4.20	23
	M3X9	23
	M3X10	23

BASKI VİDASI		FIYAT PRICE TL
	M6X0.75 TPKN 16	39

BASKI VİDASI		FIYAT PRICE TL
	M8X1 TPKN 22	51

TORX VİDALARI		FIYAT PRICE TL
	M3.5X8X4.8	23
	M3.5X8X5.3	23
	M3.5X10X5.30	23
	M3.5X11X4.80	23
	M3.5X12X5.30	23
	M3.5X14X5.30	23
	M3.5X14X4,80	23
	M4X9	23
	M4X10X5,8	23
	M4X11	23
	M4X14	23
	M4X16	23
	M4X16X7 WALTER	23
	M4.5X12	23
	M4.5X17	23
	M5X12	23
	M5X15	23
	M5X17	23
M6X16	23	

KESME KATER VİDASI		FIYAT PRICE TL
	M8X27 A4	39

P SİSTEM VİDASI		FIYAT PRICE TL
	MPV M8 U	78
	MPV M8 K	78

KÜRE TAKIM VİDALARI - BALL NOSE SCREWS

KÜRE TAKIM VİDALARI		FIYAT PRICE TL
	M3X7 D8	69
	M4X9 D10	69
	M5X10 D12	69
	M5X12 D16	69
	M5X16 D20	69
	M6X22 D25	69
	M8X25 D30	69

ALTLIKLAR - SHIMS

ALTLIK		FIYAT PRICE
		TL
	DNMG 15 - T SİSTEM	90
	DNMG 11 - T SİSTEM	78
	DNMG 11 - P SİSTEM	78
	DNMG 15 - P SİSTEM	90

ALTLIK		FIYAT PRICE
		TL
	CNMG 12 - T SİSTEM	78
	CNMG 16 - T SİSTEM	111
	CNMG 19 - T SİSTEM	134
	CNMG 12 - P SİSTEM	78
	CNMG 16 - P SİSTEM	111
	CNMG 19 - P SİSTEM	134

ALTLIK		FIYAT PRICE
		TL
	TNMG 16 - TM SİSTEM	84
	TNMG 22 - TM SİSTEM	117
	TNMG 16 - P SİSTEM	84
	TNMG 22 - P SİSTEM	117

ALTLIK		FIYAT PRICE
		TL
	WNMG 06 M SİSTEM	90
	WNMG 08 M SİSTEM	90
	WNMG 08 T SİSTEM	90
	WNMG 08 P SİSTEM	90

ALTLIK		FIYAT PRICE
		TL
	DCMT 11 S SİSTEM	78

ALTLIK		FIYAT PRICE
		TL
	VBMT 16 - S SİSTEM	84
	VNMG 16 T SİSTEM	84
	VCMT 16 S SİSTEM	84

ALTLIK		FIYAT PRICE
		TL
	KNUX 16 SAĞ C SİSTEM	107

ALTLIK		FIYAT PRICE
		TL
	KNUX 16 SOL C SİSTEM	107

ALTLIK		FIYAT PRICE
		TL
	SER 22 - S SİSTEM	108
	SIR 22 - S SİSTEM	108
	IR-ER 16 ALTLIK SER SEL/SIR SIL	108

ALTLIK		FIYAT PRICE
		TL
	SNMG 12 - T SİSTEM	78
	SNMG 15 - T SİSTEM	111
	SNMG 19 - T SİSTEM	134
	SNMG 12 - P SİSTEM	78
	SNMG 15 - P SİSTEM	111
	SNMG 19 - P SİSTEM	134

ALTLIK		FIYAT PRICE
		TL
	CCMT 12 - S SİSTEM	78

ALTLIK		FIYAT PRICE
		TL
	TCMT 16 - S SİSTEM	81

P SİSTEM LEVYE			FIYAT PRICE
			TL
	MPL 011	DNMG 11-TNMG 16-WNMG 06	108
	MPL 012	CNMG 12-DNMG15-TNMG 22-WNMG 08	108
	MPL 016	CNMG 16 - SNMG 15	108
	MPL 019	CNMG 19 - SNMG 19	108

P SİSTEM ALTLIK SACI			FIYAT PRICE
			TL
	MPS 011	DNMG 11 TNMG 16 WNMG 06	34
	MPS 012	CNMG 12 DNMG 15 TNMG 22 WNMG 08	34
	MPS 016	CNMG 16 SNMG 15	34
	MPS 019	CNMG 19 SNMG 19	34

BASKI KEPLERİ - CLAMPS

BASKI PABUCU		FIYAT PRICE TL
	T190105 CNMG 19	130
	T190105 SNMG 19	130

BASKI PABUCU		FIYAT PRICE TL
	M160105 TNMG 16 M	102
	M220105 TNMG 22 M	102

BASKI PABUCU		FIYAT PRICE TL
	T110105 DNMG 11 T SİSTEM	78
	T160105 TNMG 16 T SİSTEM	78
	T060105 WNMG 06 T SİSTEM	78

BASKI PABUCU		FIYAT PRICE TL
	C110105 SN..12 T	107
	T120105 CNMG 12 T	102
	T150105 DNMG 15 T	102
	T150105 SNMG 15 T	115
	T220105 TNMG 22 T	102
	T080105 WNMG08 T	102

BASKI PABUCU		FIYAT PRICE TL
	T160105 CNMG 16	115
	T160105 VNMG 16	115
	T160105 SNMG 15	115

BASKI PABUCU		FIYAT PRICE TL
	M060105 WNMG 06 M SİSTEM	78

BASKI PABUCU		FIYAT PRICE TL
	C160105 KNUX 16 SAĞ	108
	C160105 KNUX 16 SOL	108
	C160105 KNUX 16 SOL VE SAĞ	90

BASKI PABUCU		FIYAT PRICE TL
	CK 14	108
	CK 15	108

BASKI PABUCU		FIYAT PRICE TL
	C160105 TPKN 16	107

BASKI PABUCU		FIYAT PRICE TL
	M080105 WNMG 08	107

M SİSTEM ALTLIK PİMİ		FIYAT PRICE TL
	6X5X18 TNMG 22	34
	6X5X18 WNMG 08	34
	5x3.6x15 TNMG 16	34

BASKI PABUÇ YAYI		FIYAT PRICE TL
	BASKI PABUÇU YAYI	10

BASKI PABUÇ VİDASI PULU		FIYAT PRICE TL
	10X6X1 MM	10

TORNALAMA İÇİN FORMÜLLER

DEVİR SAYISI = $n = \frac{V_c \times 1000}{\pi \times D}$ devir / dakika Revolutions / Umdrehungen $\pi \times D$ Revs / min. Umdrehungen / min.	n: Devir Sayısı (dev./dak) Revolutions / Umdrehungen $\frac{Revs}{min.}$ Umdrehungen/min.
KESME HIZI = $V_c = \frac{\pi \times D \times n}{1000}$ metre / dakika Cutting speed $\frac{\pi \times D \times n}{1000}$ meter / min. Schnittgeschwindigkeit	Vc: Kesme Hızı (m./dak.) Cutting Speed / Schnittgeschwindigkeit (Meter/Min)
	D: İş Parçasının Çapı (mm) Workpiece diameter / Werkstückdurchmesser
	π: Sabit Sayı(3,14) Constant (3,14) / Gleich bleibend (3,14)

TORNALAMA İŞLEMİNDE ZAMANININ HESAPLANMASI

Çap Tornalamada = $th = \frac{L \times Ps}{n \times f}$ dakika Turning diameter / Drehdurchmesser $\frac{L \times Ps}{n \times f}$ min.	Ps: Paso Sayısı (kaç defada) no of passes / Durchgänge
	th: İşleme Zamanı (dakika) Processing Time / Bearbeitungszeit (min)
	f: İlerleme (mm) Length delivery / Stirn Zustellung (min.)
Alın Tornalama = $th = \frac{d \times \pi \times L \times Ps}{V_c \times 1000 \times f}$ dakika Length turning / Stirn Drehen $\frac{d \times \pi \times L \times Ps}{V_c \times 1000 \times f}$ min.	Alın Tornalama için Boy Length for face turning / Länge für Stirn Drehen $L = \frac{d1 - d2}{2}$ mm
	Dolu Malzemede Alın Tornalama Face turning for solid tool / Massive Werkstücke Stirn Drehen $L = \frac{d}{2}$ mm

YÜZEY FREZELEMEDE KULLANILAN FORMÜLLER

DEVİR SAYISI = $n = \frac{V_c \times 1000}{\pi \times D}$ devir / dakika Revolutions / Umdrehungen $\pi \times D$ Revs / min. Umdrehungen / min.	z: Frezenin Ağız Sayısı (adet) Number of tooth / Anzahl Schneiden
KESME HIZI = $V_c = \frac{\pi \times D \times n}{1000}$ metre / dakika Revolutions / Umdrehungen $\frac{\pi \times D \times n}{1000}$ meter / min.	k: Disk Frezenin Efektif Ağız sayısı (adet) Effective edge of the cutter / Effektive Schneiden des Fräasers
	fz : Ağız başına ilerleme (mm/ağız) Delivery per cutting mm /Z/ Zustellung pro Schneide mm/Z
TABLA İLERLEMESİ = $V_f = n \times z \times fz$ mm/dak Delivery / Zustellung $n \times z \times fz$ mm / min.	th: İşleme Zamanı (dak.) Processing time / Bearbeitungszeit minute
	Ps : Paso Sayısı Number of passes / Anzahl der Durchgänge

PLASMA NITRATION

Nedir?

Vasıflı çelik malzemelerde uygulanabilen bir yüzey sertleştirme yöntemidir. İşlem için özel tasarlanmış vakum fırınlarında, elektrik akımı vasıtasıyla proses gazlarının iyonize edilerek iş parçalarına yönlendirilmesi sayesinde gerçekleşir.

What Is It?

It is surface hardening method which can be applied inskilled steel materials. The procedure takes place inspecial designed vacuum furnaces by means of electric current in ionizing the process gases and directing them to workpieces.

Avantajlar

- Aşınma direncini artırır.
- Yorulma ömrünü uzatır.
- Çarpılma riski minimum düzeydedir.
- Yüksek yüzey sertliği sağlar.
- Ölçü hassasiyeti yüksektir.
- Korozyon direncini artırır.
- Temiz ve parlak yüzeyler elde edilir.
- Sertlik dağılımı homojendir.
- Çevreyi kirletmez.
- Çalışan sağlığına zarar vermez.

Advantages

- Increases wear resistance.
- Extends fatigue life.
- The risk of distortion is minimal.
- Provides high surface hardness.
- Measurement accuracy is high.
- Increases corrosion resistance.
- Clean and shiny surfaces are obtained.
- Hardness distribution is homogeneous.
- Does not pollute the environment.
- Does not harm employee health.

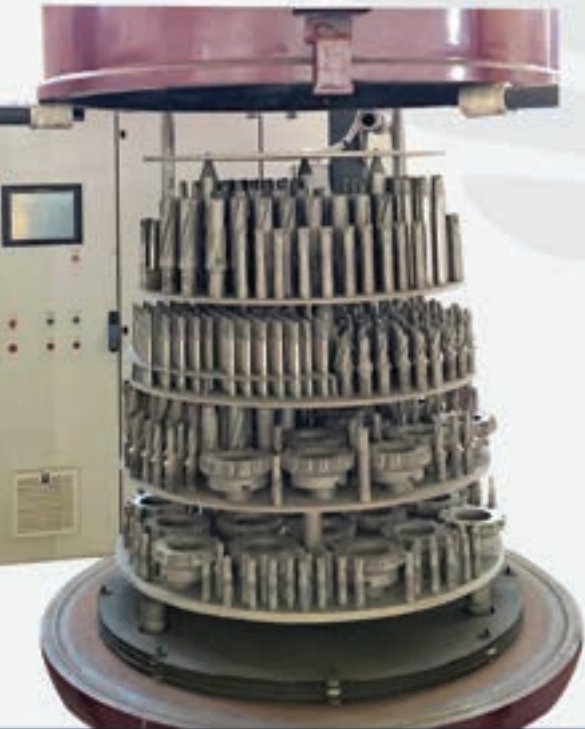
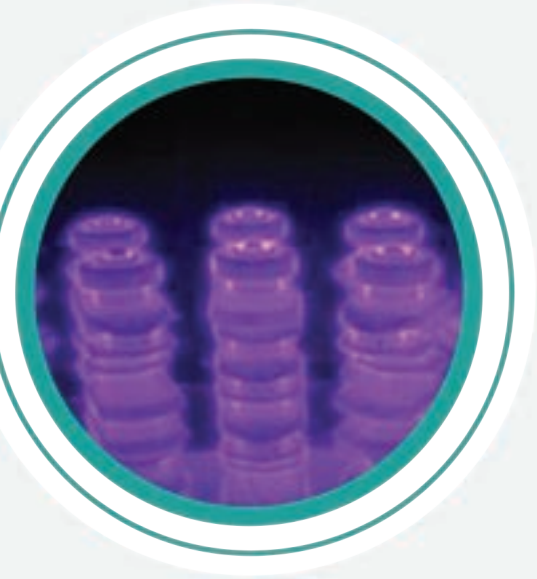



Organize Sanayi Bölgesi 40. Sok. No:19 BURDUR



T. +90 248 252 81 15 - 252 81 65 F. +90 248 252 99 37



info@baydarlar.com - info@mbckesicitakim.com



www.baydarlar.com